

OPERATOR'S MANUAL

CRAFTSMAN®

10 in. TABLE SAW

Model No.
315.284620

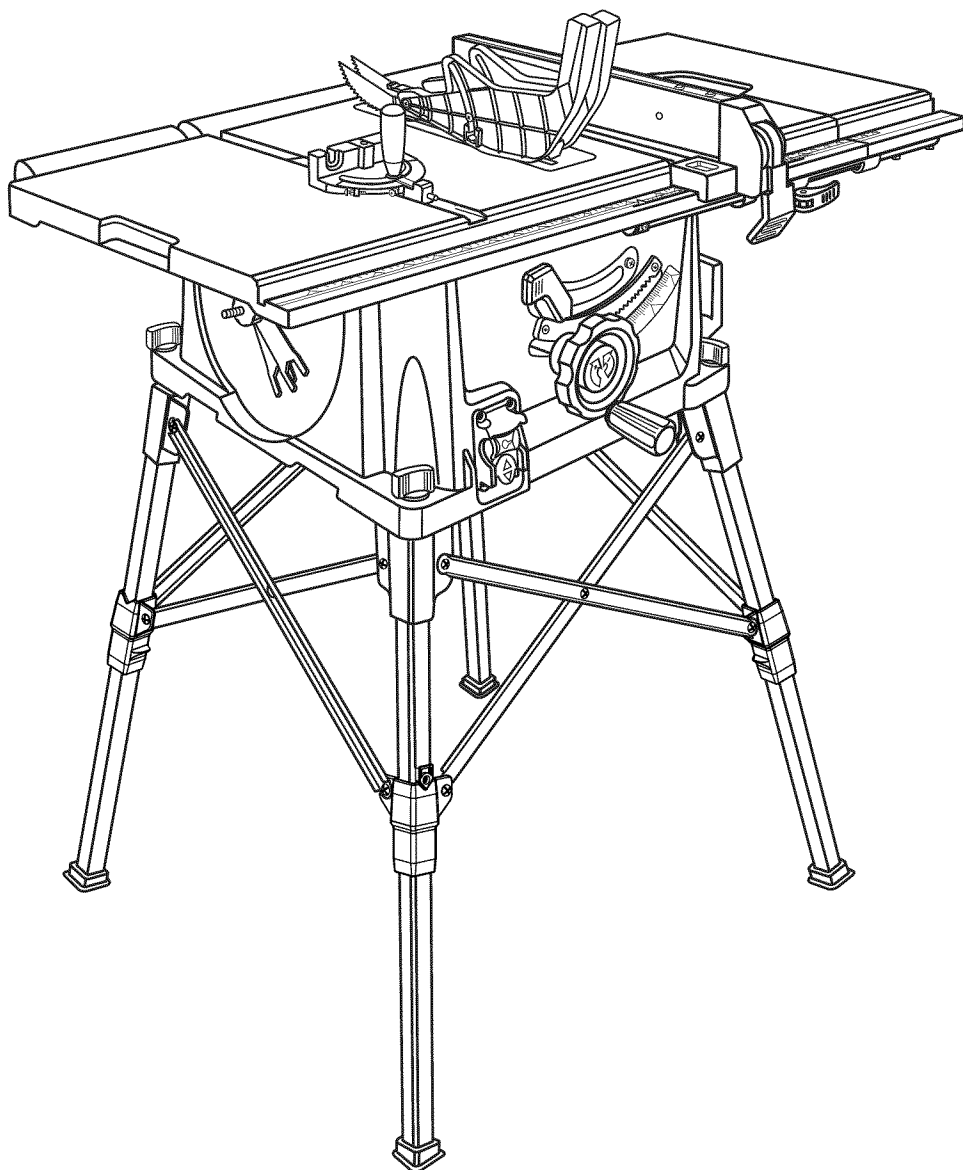

WARNING: To reduce the risk of injury, the user must read and understand the operator's manual before using this product.

Customer Help Line: 1-800-932-3188

Product distributed in the United States by Sears Brands Management Corporation
Hoffman Estates, IL 60179

Visit the Craftsman web page: www.craftsman.com

987000-910
4-23-10 (REV:03)

Save this manual for future reference



TABLE OF CONTENTS

■ Warranty	2
■ Introduction	2
■ General Safety Rules	3-4
■ Specific Safety Rules.....	4-5
■ Symbols.....	6-7
■ Electrical	8
■ Glossary of Terms.....	9
■ Features.....	10-13
■ Tools Needed	13
■ Loose Parts	14
■ Assembly.....	15-21
■ Operation.....	22-35
■ Adjustments.....	36-38
■ Maintenance.....	38
■ Accessories	39
■ Troubleshooting.....	39-40
■ Illustrated Parts List.....	41-50
■ Parts Ordering/Service	Back Page

WARRANTY

CRAFTSMAN ONE YEAR FULL WARRANTY

FOR ONE YEAR from the date of purchase, this product is warranted against any defects in material or workmanship. Defective product will receive free repair or free replacement if repair is unavailable.

For warranty coverage details to obtain repair or replacement, visit the web site: www.craftsman.com

This warranty does not cover the blade, which is an expendable part that can wear out from normal use within the warranty period.

This warranty is void if this product is ever used while providing commercial services or if rented to another person.

This warranty gives you specific legal rights, and you may also have other rights which vary from state to state.

Sears Brands Management Corporation, Hoffman Estates, IL 60179

INTRODUCTION

This tool has many features for making its use more pleasant and enjoyable. Safety, performance, and dependability have been given top priority in the design of this product making it easy to maintain and operate.

GENERAL SAFETY RULES

⚠ WARNING: Read and understand all instructions. Failure to follow all instructions listed below, may result in electric shock, fire and/or serious personal injury.

READ ALL INSTRUCTIONS

- **KNOW YOUR POWER TOOL.** Read the operator's manual carefully. Learn the saw's applications and limitations as well as the specific potential hazards related to this tool.
- **GUARD AGAINST ELECTRICAL SHOCK BY PREVENTING BODY CONTACT WITH GROUNDED SURFACES.** For example, pipes, radiators, ranges, refrigerator enclosures.
- **KEEP GUARDS IN PLACE** and in good working order.
- **REMOVE ADJUSTING KEYS AND WRENCHES.** Form habit of checking to see that keys and adjusting wrenches are removed from tool before turning it on.
- **KEEP WORK AREA CLEAN.** Cluttered areas and benches invite accidents. **DO NOT** leave tools or pieces of wood on the saw while it is in operation.
- **DO NOT USE IN DANGEROUS ENVIRONMENTS.** Do not use power tools in damp or wet locations or expose to rain. Keep the work area well lit.
- **KEEP CHILDREN AND VISITORS AWAY.** All visitors should wear safety glasses and be kept a safe distance from work area. Do not let visitors contact tool or extension cord while operating.
- **MAKE WORKSHOP CHILDPROOF** with padlocks and master switches, or by removing starter keys.
- **DON'T FORCE TOOL.** It will do the job better and safer at the feed rate for which it was designed.
- **USE RIGHT TOOL.** Don't force the tool or attachment to do a job it was not designed for. Don't use it for a purpose not intended.
- **USE THE PROPER EXTENSION CORD.** Make sure your extension cord is in good condition. Use only a cord heavy enough to carry the current your product will draw. An undersized cord will cause a drop in line voltage resulting in loss of power and overheating. A wire gauge size (A.W.G.) of at least **14** is recommended for an extension cord 25 feet or less in length. If in doubt, use the next heavier gauge. The smaller the gauge number, the heavier the cord.
- **DRESS PROPERLY.** Do not wear loose clothing, gloves, neckties, or jewelry. They can get caught and draw you into moving parts. Rubber gloves and nonskid footwear are recommended when working outdoors. Also wear protective hair covering to contain long hair.
- **ALWAYS WEAR SAFETY GLASSES WITH SIDE SHIELDS.** Everyday eyeglasses have only impact-resistant lenses, they are **NOT** safety glasses.
- **SECURE WORK.** Use clamps or a vise to hold work when practical. It's safer than using your hand and frees both hands to operate tool.
- **DON'T OVERREACH.** Keep proper footing and balance at all times.
- **MAINTAIN TOOLS WITH CARE.** Keep tools sharp and clean for better and safer performance. Follow instructions for lubricating and changing accessories.
- **DISCONNECT TOOLS.** When not in use, before servicing, or when changing attachments, blades, bits, cutters, etc., all tools should be disconnected.
- **AVOID ACCIDENTAL STARTING.** Be sure switch is off when plugging in any tool.
- **USE RECOMMENDED ACCESSORIES.** Consult the operator's manual for recommended accessories. The use of improper accessories may risk injury.
- **NEVER STAND ON TOOL.** Serious injury could occur if the tool is tipped or if the cutting tool is unintentionally contacted.
- **CHECK DAMAGED PARTS.** Before further use of the tool, a guard or other part that is damaged should be carefully checked to determine that it will operate properly and perform its intended function. Check for alignment of moving parts, binding of moving parts, breakage of parts, mounting and any other conditions that may affect its operation. A guard or other part that is damaged must be properly repaired or replaced by an authorized service center to avoid risk of personal injury.
- **USE THE RIGHT DIRECTION OF FEED.** Feed work into a blade or cutter against the direction of rotation of blade or cutter only.
- **NEVER LEAVE TOOL RUNNING UNATTENDED. TURN THE POWER OFF.** Don't leave tool until it comes to a complete stop.
- **PROTECT YOUR LUNGS.** Wear a face or dust mask if the cutting operation is dusty.
- **PROTECT YOUR HEARING.** Wear hearing protection during extended periods of operation.
- **DO NOT ABUSE CORD.** Never yank cord to disconnect from receptacle. Keep cord from heat, oil, and sharp edges.
- **WHEN OPERATING A POWER TOOL OUTSIDE, USE AN OUTDOOR EXTENSION CORD MARKED "W-A" OR "W".** These cords are rated for outdoor use and reduce the risk of electric shock.
- **KEEP BLADES CLEAN, SHARP, AND WITH SUFFICIENT SET.** Sharp blades minimize stalling and kickback.
- **KEEP HANDS AWAY FROM CUTTING AREA.** Keep hands away from blades. Do not reach underneath work or around or over the blade while blade is rotating. Do not attempt to remove cut material when blade is moving.

GENERAL SAFETY RULES

- **BLADE COASTS AFTER BEING TURNED OFF.**
- **NEVER USE IN AN EXPLOSIVE ATMOSPHERE.** Normal sparking of the motor could ignite fumes.
- **INSPECT TOOL CORDS PERIODICALLY.** If damaged, have repaired by a qualified service technician at an authorized service facility. The conductor with insulation having an outer surface that is green with or without yellow stripes is the equipment-grounding conductor. If repair or replacement of the electric cord or plug is necessary, do not connect the equipment-grounding conductor to a live terminal. Repair or replace a damaged or worn cord immediately. Stay constantly aware of cord location and keep it well away from the rotating blade.
- **INSPECT EXTENSION CORDS PERIODICALLY** and replace if damaged.
- **GROUND ALL TOOLS.** If tool is equipped with three-prong plug, it should be plugged into a three-hole electrical receptacle.
- **CHECK WITH A QUALIFIED ELECTRICIAN** or service personnel if the grounding instructions are not completely understood or if in doubt as to whether the tool is properly grounded.
- **USE ONLY CORRECT ELECTRICAL DEVICES:** 3-wire extension cords that have 3-prong grounding plugs and 3-pole receptacles that accept the tool's plug.
- **DO NOT MODIFY** the plug provided. If it will not fit the outlet, have the proper outlet installed by a qualified electrician.
- **KEEP TOOL DRY, CLEAN, AND FREE FROM OIL AND GREASE.** Always use a clean cloth when cleaning. Never use brake fluids, gasoline, petroleum-based products, or any solvents to clean tool.
- **STAY ALERT AND EXERCISE CONTROL.** Watch what you are doing and use common sense. Do not operate tool when you are tired. Do not rush.
- **DO NOT USE TOOL IF SWITCH DOES NOT TURN IT ON AND OFF.** Have defective switches replaced by an authorized service center.
- **USE ONLY CORRECT BLADES.** Do not use blades with incorrect size holes. Never use blade washers or blade bolts that are defective or incorrect. The maximum blade capacity of your saw is 10 in. (254 mm).
- **BEFORE MAKING A CUT, BE SURE ALL ADJUSTMENTS ARE SECURE.**
- **BE SURE BLADE PATH IS FREE OF NAILS.** Inspect for and remove all nails from lumber before cutting.
- **NEVER TOUCH BLADE** or other moving parts during use.
- **NEVER START A TOOL WHEN ANY ROTATING COMPONENT IS IN CONTACT WITH THE WORKPIECE.**
- **DO NOT OPERATE A TOOL WHILE UNDER THE INFLUENCE OF DRUGS, ALCOHOL, OR ANY MEDICATION.**
- **WHEN SERVICING** use only identical replacement parts. Use of any other parts may create a hazard or cause product damage.
- **USE ONLY RECOMMENDED ACCESSORIES** listed in this manual or addendums. Use of accessories that are not listed may cause the risk of personal injury. Instructions for safe use of accessories are included with the accessory.
- **DOUBLE CHECK ALL SETUPS.** Make sure blade is tight and not making contact with saw or workpiece before connecting to power supply.

SPECIFIC SAFETY RULES







- **FIRMLY BOLT THE SAW TO A WORK BENCH OR LEG STAND** at approximately hip height.
- **NEVER OPERATE THE SAW ON THE FLOOR.**
- **GUARD AGAINST KICKBACK.** Kickback occurs when the blade stalls rapidly and workpiece is driven back towards the operator. It can pull your hand into the blade resulting in serious personal injury. Stay out of blade path and turn switch off immediately if blade binds or stalls.
- **USE RIP FENCE.** Always use a fence or straight edge guide when ripping.
- **SUPPORT LARGE PANELS.** To minimize risk of blade pinching and kickback, always support large panels.
- **REMOVE ALL FENCES AND AUXILIARY TABLES** before transporting saw. Failure to do so can result in an accident causing possible serious personal injury.
- **ALWAYS USE BLADE GUARD, SPREADER, AND ANTI-KICKBACK PAWLS** on all "through-sawing" operations. Through-sawing operations are those in which the blade cuts completely through the workpiece as in ripping or cross cutting. Keep the blade guard down, the anti-kickback pawls down, and the spreader in place.
- **ALWAYS SECURE WORK** firmly against the rip fence or miter gauge. NEVER use the rip fence during the same operation as the miter gauge.
- **WHEN MAKING NON-THROUGH RIP CUTS,** always use a push stick, push block, and/or featherboard so your hands do not come within 3 inches of the saw blade.
- **WHEN RIPPING NARROW STOCK,** always use a push stick, push block, or featherboard.

SPECIFIC SAFETY RULES

- **NEVER** perform any operation “freehand” which means using only your hands to support or guide the workpiece. Always use either the rip fence or miter gauge to position and guide the work.
- **NEVER** stand or have any part of your body in line with the path of the saw blade.
- **NEVER** reach behind, over, or within three inches of the blade or cutter with either hand for any reason.
- **MOVE THE RIP FENCE** out of the way when cross cutting.
- **NEVER** use rip fence as cutoff gauge when cross cutting.
- **NEVER** attempt to free a stalled saw blade without first turning the saw **OFF** and disconnecting the saw from the power source.
- **PROVIDE ADEQUATE SUPPORT** to the rear and sides of the saw table for wide or long workpieces.
- **AVOID KICKBACKS** (work thrown back toward you) by:
 - a) Keeping blade sharp.
 - b) Keeping rip fence parallel to the saw blade.
 - c) Keeping spreader, anti-kickback pawls, and blade guard in place and operating.
 - d) Not releasing the work before it is pushed all the way past the saw blade using a push stick.
 - e) Not ripping work that is twisted or warped or does not have a straight edge to guide along the fence.
- **IF THE POWER SUPPLY CORD IS DAMAGED**, it must be replaced only by the manufacturer or by an authorized service center to avoid risk.
- **AVOID AWKWARD OPERATIONS AND HAND POSITIONS** where a sudden slip could cause your hand to move into the cutting tool.
- **USE ONLY RECOMMENDED ACCESSORIES** listed in this manual or addendums. Use of accessories that are not listed may cause the risk of personal injury. Instructions for safe use of accessories are included with the accessory.
- **MAKE SURE THE WORK AREA HAS AMPLE LIGHTING** to see the work and that no obstructions will interfere with safe operation **BEFORE** performing any work using the table saw.
- **ALWAYS TURN OFF SAW** before disconnecting it, to avoid accidental starting when reconnecting to power supply.
- **HOLD THE WORKPIECE FIRMLY AGAINST THE TABLE.**
- **THIS TOOL** should have the following markings:
 - a) Wear eye protection.
 - b) Use saw blade guard and riving knife/spreader/splitter for every operation for which it can be used, including all through sawing.
 - c) Keep hands out of the line of saw blade.
 - d) Use a push stick when required.
 - e) Pay particular attention to instructions on reducing risk of kickback.
 - f) Do not perform any operation freehand.
 - g) Never reach around or over the saw blade.
 - h) Never operate saw on floor or below waist height.
- **SAVE THESE INSTRUCTIONS.** Refer to them frequently and use to instruct other users. If you loan someone this tool, loan them these instructions also.



SYMBOLS

Some of the following symbols may be used on this tool. Please study them and learn their meaning. Proper interpretation of these symbols will allow you to operate the tool better and safer.

	Safety Alert	Indicates a potential personal injury hazard.
	Read Operator's Manual	To reduce the risk of injury, user must read and understand operator's manual before using this product.
	Eye Protection	Always wear eye protection with side shields marked to comply with ANSI Z87.1.
	No Hands Symbol	Failure to keep your hands away from the blade will result in serious personal injury.
	Wet Conditions Alert	Do not expose to rain or use in damp locations.
V	Volts	Voltage
A	Amperes	Current
Hz	Hertz	Frequency (cycles per second)
W	Watt	Power
min	Minutes	Time
~	Alternating Current	Type of current
==	Direct Current	Type or a characteristic of current
n_0	No Load Speed	Rotational speed, at no load
	Class II Construction	Double-insulated construction
.../min	Per Minute	Revolutions, strokes, surface speed, orbits etc., per minute

SYMBOLS

The following signal words and meanings are intended to explain the levels of risk associated with this product.

SYMBOL	SIGNAL	MEANING
	DANGER:	Indicates an imminently hazardous situation, which, if not avoided, will result in death or serious injury.
	WARNING:	Indicates a potentially hazardous situation, which, if not avoided, could result in death or serious injury.
	CAUTION:	Indicates a potentially hazardous situation, which, if not avoided, may result in minor or moderate injury.
	CAUTION:	(Without Safety Alert Symbol) Indicates a situation that may result in property damage.

SERVICE

Servicing requires extreme care and knowledge and should be performed only by a qualified service technician. For service we suggest you return the product to your nearest **AUTHORIZED SERVICE CENTER** for repair. When servicing, use only identical replacement parts.



WARNING: To avoid serious personal injury, do not attempt to use this product until you read thoroughly and understand completely the operator's manual. Save this operator's manual and review frequently for continuing safe operation and instructing others who may use this product.



WARNING:



The operation of any power tool can result in foreign objects being thrown into your eyes, which can result in severe eye damage. Before beginning power tool operation, always wear safety goggles or safety glasses with side shields and a full face shield when needed. We recommend Wide Vision Safety Mask for use over eyeglasses or standard safety glasses with side shields. Always use eye protection which is marked to comply with ANSI Z87.1.

SAVE THESE INSTRUCTIONS

ELECTRICAL

EXTENSION CORDS

Use only 3-wire extension cords that have 3-prong grounding plugs and 3-pole receptacles that accept the tool's plug. When using a power tool at a considerable distance from the power source, use an extension cord heavy enough to carry the current that the tool will draw. An undersized extension cord will cause a drop in line voltage, resulting in a loss of power and causing the motor to overheat. Use the chart provided below to determine the minimum wire size required in an extension cord. Only round jacketed cords listed by Underwriter's Laboratories (UL) should be used.

**Ampere rating (on tool data plate)

	0-2.0	2.1-3.4	3.5-5.0	5.1-7.0	7.1-12.0	12.1-16.0
Cord Length	Wire Size (A.W.G.)					
25'	16	16	16	16	14	14
50'	16	16	16	14	14	12
100'	16	16	14	12	10	—

**Used on 12 gauge - 20 amp circuit.

NOTE: AWG = American Wire Gauge

When working with the tool outdoors, use an extension cord that is designed for outside use. This is indicated by the letters "WA" on the cord's jacket.

Before using an extension cord, inspect it for loose or exposed wires and cut or worn insulation.

⚠ WARNING: Keep the extension cord clear of the working area. Position the cord so that it will not get caught on lumber, tools or other obstructions while you are working with a power tool. Failure to do so can result in serious personal injury.

⚠ WARNING: Check extension cords before each use. If damaged replace immediately. Never use tool with a damaged cord since touching the damaged area could cause electrical shock resulting in serious injury.

ELECTRICAL CONNECTION

This tool is powered by a precision built electric motor. It should be connected to a **power supply that is 120 volts, AC only (normal household current), 60 Hz.** Do not operate this tool on direct current (DC). A substantial voltage drop will cause a loss of power and the motor will overheat. If the saw does not operate when plugged into an outlet, double check the power supply.

SPEED AND WIRING

The no-load speed of this tool is approximately 5,000 rpm. This speed is not constant and decreases under a load or with lower voltage. For voltage, the wiring in a shop is as important as the motor's horsepower rating. A line intended only for lights cannot properly carry a power tool motor. Wire that is heavy enough for a short distance will be too light for a greater distance. A line that can support one power tool may not be able to support two or three tools.

GROUNDING INSTRUCTIONS

This product must be grounded. In the event of a malfunction or breakdown, grounding provides a path of least resistance for electric current to reduce the risk of electric shock. This tool is equipped with an electric cord having an equipment-grounding conductor and a grounding plug. The plug must be plugged into a matching outlet that is properly installed and grounded in accordance with all local codes and ordinances.

Do not modify the plug provided. If it will not fit the outlet, have the proper outlet installed by a qualified electrician.

⚠ WARNING: Improper installation of the grounding plug can result in a risk of electric shock. When repair or replacement of the cord is required, do not connect the grounding wire to either flat blade terminal. The wire with insulation having an outer surface that is green with or without yellow stripes is the grounding wire.

Check with a qualified electrician or service personnel if the grounding instructions are not completely understood, or if in doubt as to whether the tool is properly grounded.

Repair or replace a damaged or worn cord immediately.

This product is for use on a nominal 120 volt circuit and has a grounding plug similar to the plug illustrated in figure 1. Only connect the product to an outlet having the same configuration as the plug. Do not use an adapter with this product.

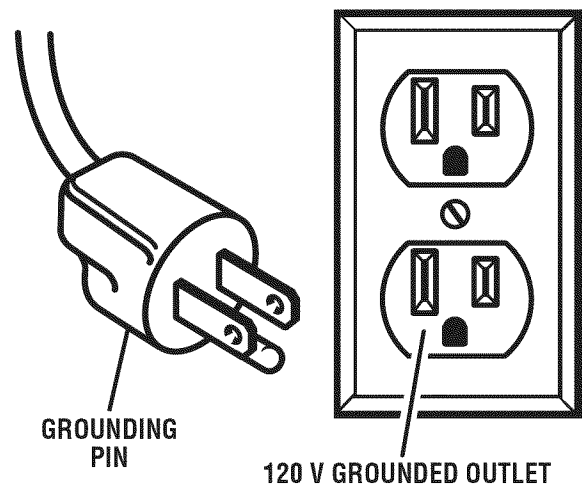

Fig. 1

GLOSSARY OF TERMS

Anti-Kickback Pawls (radial arm and table saws)

A device which, when properly installed and maintained, is designed to stop the workpiece from being kicked back toward the front of the saw during a ripping operation.

Arbor

The shaft on which a blade or cutting tool is mounted.

Bevel Cut

A cutting operation made with the blade at any angle other than 90° to the table surface.

Compound Cut

A cross cut made with both a miter and a bevel angle.

Cross Cut

A cutting or shaping operation made across the grain or the width of the workpiece.

Cutterhead (planers and jointer planers)

A rotating cutterhead with adjustable blades or knives. The blades or knives remove material from the workpiece.

Dado Cut

A non-through cut which produces a square-sided notch or trough in the workpiece (requires a special blade).

Featherboard

A device used to help control the workpiece by holding it securely against the table or fence during any ripping operation.

FPM or SPM

Feet per minute (or strokes per minute), used in reference to blade movement.

Freehand

Performing a cut without the workpiece being guided by a fence, miter gauge, or other aids.

Gum

A sticky, sap-based residue from wood products.

Heel

Alignment of the blade to the fence.

Kerf

The material removed by the blade in a through cut or the slot produced by the blade in a non-through or partial cut.

Kickback

A hazard that can occur when the blade binds or stalls, throwing the workpiece back toward operator.

Miter Cut

A cutting operation made with the workpiece at any angle to the blade other than 90°.

Non-Through Cuts

Any cutting operation where the blade does not extend completely through the thickness of the workpiece.

Pilot Hole (drill presses)

A small hole drilled in a workpiece that serves as a guide for drilling large holes accurately.

Push Blocks (for jointer planers)

Device used to feed the workpiece over the jointer planer cutterhead during any operation. This aid helps keep the operator's hands well away from the cutterhead.

Push Blocks (for table saws)

Device used to hold the workpiece during cutting operations. This aid helps keep the operator's hands well away from the blade.

Push Sticks (for table saws)

Device used to push the workpiece during cutting operations. A push stick should be used for narrow ripping operations. The aid helps keep the operator's hands well away from the blade.

Resaw

A cutting operation to reduce the thickness of the workpiece to make thinner pieces.

Resin

A sticky, sap-based substance that has hardened.

Revolutions Per Minute (RPM)

The number of turns completed by a spinning object in one minute.

Ripping or Rip Cut

A cutting operation along the length of the workpiece.

Riving Knife/Spreader/Splitter (table saws)

A metal piece, slightly thinner than the blade, which helps keep the kerf open and also helps to prevent kickback.

Saw Blade Path

The area over, under, behind, or in front of the blade. As it applies to the workpiece, that area which will be or has been cut by the blade.

Set

The distance that the tip of the saw blade tooth is bent (or set) outward from the face of the blade.

Snipe (planers)

Depression made at either end of a workpiece by cutter blades when the workpiece is not properly supported.

Through Sawing

Any cutting operation where the blade extends completely through the thickness of the workpiece.

Throw-Back

The throwing back of a workpiece usually caused by the workpiece being dropped into the blade or being placed inadvertently in contact with the blade.

Workpiece or Material

The item on which the operation is being done.

Worktable

Surface where the workpiece rests while performing a cutting, drilling, planing, or sanding operation.

FEATURES

PRODUCT SPECIFICATIONS

Blade Arbor	5/8 in.	Input	15 Amps
Blade Diameter.....	10 in.	No Load Speed	5,000 r/min. (RPM)
Blade Tilt	0° - 45°	Cutting Depth at 0°	3-1/2 in.
Rating	120 V, AC only, 60 Hz	Cutting Depth at 45°	2-1/2 in.

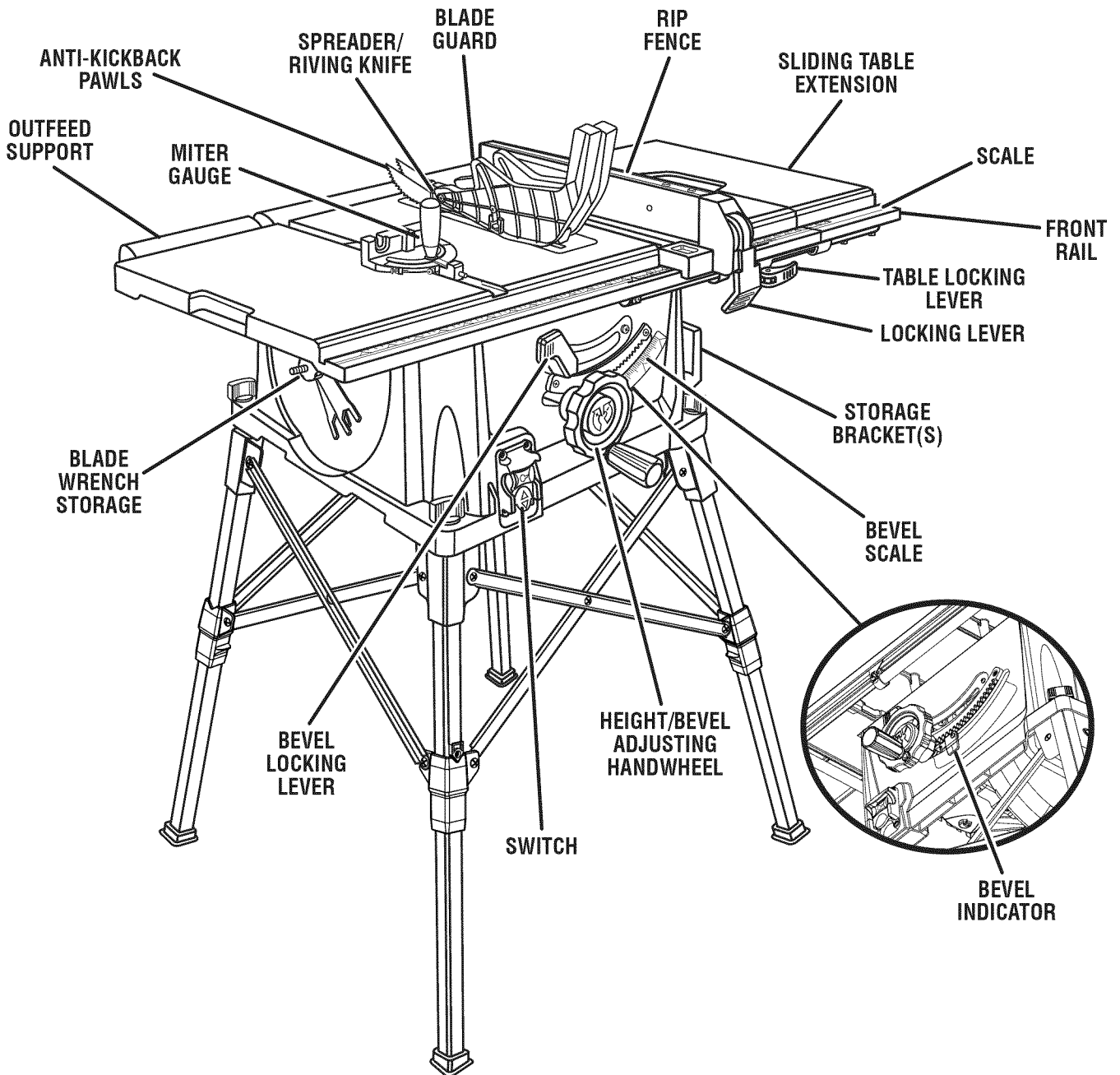

Fig. 2

FEATURES

KNOW YOUR TABLE SAW

See Figure 2.

The safe use of this product requires an understanding of the information on the tool and in this operator's manual as well as a knowledge of the project you are attempting. Before use of this product, familiarize yourself with all operating features and safety rules.

ANTI-KICKBACK PAWLS - Kickback is a hazard in which the workpiece is thrown back toward the operator. The teeth on the anti-kickback pawls point away from the workpiece. If the workpiece should be pulled back toward the operator, the teeth dig into the wood to help prevent or reduce the possibility of kickback.

BEVEL SCALE - The easy-to-read scale on the front of the cabinet shows the exact blade angle.

BLADE - This saw is provided with a 36-tooth, 10 in. carbide blade. The blade is raised and lowered with the height/bevel adjusting handwheel. Bevel angles are locked with the bevel locking lever.

 **WARNING:** Do not use blades rated less than the speed of this tool. Failure to heed this warning could result in personal injury.

BLADE GUARD - Always keep the blade guard down over the saw blade for through-sawing cuts.

BEVEL LOCKING LEVER - This lever, placed just under the saw table surface on the front of the cabinet, locks the angle setting of the blade.

HEIGHT/BEVEL ADJUSTING HANDWHEEL - Located on the front of the cabinet, use this handwheel to lower and raise the blade for height adjustments or blade replacement. This handwheel also makes the adjustment for bevel angles easy.

MITER GAUGE - The miter gauge aligns the wood for a cross cut. The easy-to-read indicator shows the exact angle for a miter cut, with positive stops at 90° and 45°.

MITER GAUGE GROOVES - The miter gauge rides in the grooves on the saw table.

OUTFEED SUPPORT - This table extension at the back of the tool gives the operator additional support when cutting long workpieces.

RIP FENCE - A sturdy metal fence guides the workpiece and is secured with the locking handle. Grooves run along the top and sides of the rip fence for use with optional clamps and accessories.

SCALE - Located on the front rail, the easy-to-read scale provides precise measurements for rip cuts.

SLIDING TABLE EXTENSIONS - Located on each side of the saw table, these table extension gives the operator additional support when cutting wide workpieces.

SPREADER/RIVING KNIFE - A removable metal piece of the blade guard assembly, slightly thinner than the saw blade, which helps keep the kerf open and prevent kickback. When in the through sawing, or "up" position, it is higher than the saw blade and becomes a spreader. When in the non-through sawing, or "down" position, it is below the saw blade teeth and becomes a riving knife.

SWITCH ASSEMBLY - This saw has an easy access power switch located below the front rail. To lock the switch in the **OFF** position, remove the switch key from the switch. Place the key in a location that is inaccessible to children and others not qualified to use the tool.

FEATURES

OPERATING COMPONENTS

The upper portion of the blade projects up through the table and is surrounded by an insert called the throat plate. The height of the blade is set with a handwheel on the front of the cabinet. To accommodate wide panels, the saw table has rails on each side. Detailed instructions are provided in the *Operation* section of this manual for the basic cuts: cross cuts, miter cuts, bevel cuts, and compound cuts.

The rip fence is used to position work for lengthwise cuts. A scale on the front rail shows the distance between the rip fence and the blade.

It is very important to use the blade guard assembly for all through-sawing operations. The blade guard assembly includes: riving knife/spreader/splitter, anti-kickback pawls, and plastic blade guard.

POWER SWITCH

This saw is equipped with a power switch that has a built-in locking feature. This feature is intended to prevent unauthorized and possible hazardous use by children and others.

TO TURN YOUR SAW ON:

- With the switch key inserted into the switch, lift the switch button to turn **ON (I)**.

TO TURN YOUR SAW OFF:

- Press the switch button down to turn **OFF (O)**.

TO LOCK YOUR SAW:

- Press the switch button down.
- Remove the switch key from the switch and store in a safe, secure location.

WARNING: Always remove the switch key when the tool is not in use and keep it in a safe place. In the event of a power failure, turn the switch **OFF (O)** and remove the key. This action will prevent the tool from accidentally starting when power returns.

WARNING: ALWAYS make sure your workpiece is not in contact with the blade before operating the switch to start the tool. Failure to heed this warning may cause the workpiece to be kicked back toward the operator and result in serious personal injury.

WARNING: To reduce the risk of accidental starting, Always make sure the switch is in the **OFF (O)** position before plugging tool into the power source.

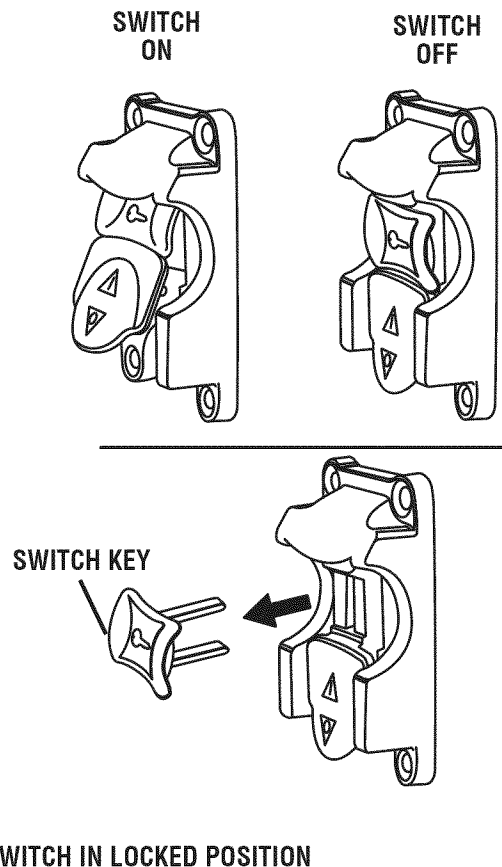

Fig. 3

FEATURES

BLADES

For maximum performance, it is recommended that you use the 36-tooth, 10 in. carbide-tipped combination blade provided with your saw. Additional blade styles of the same high quality are available for specific operations such as ripping. Your local dealer can provide you with complete information.

Kerf width must be within the limits stamped on the spreader/ripping knife.

WARNING: Do not use blades rated less than the speed of this tool. Failure to heed this warning could result in personal injury.

TOOLS NEEDED

The following tools (not included or drawn to scale) are needed for assembly and making adjustments:

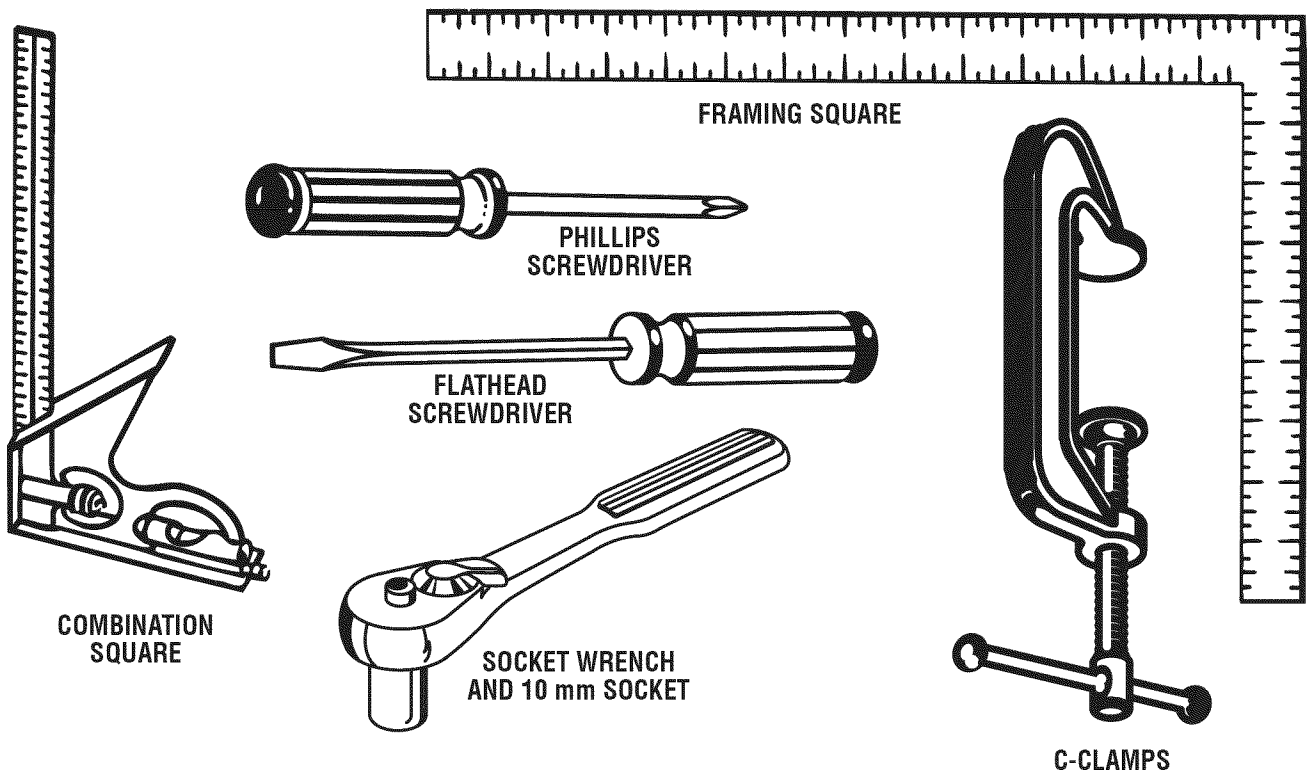

Fig. 4

LOOSE PARTS

The following items are included with your table saw:

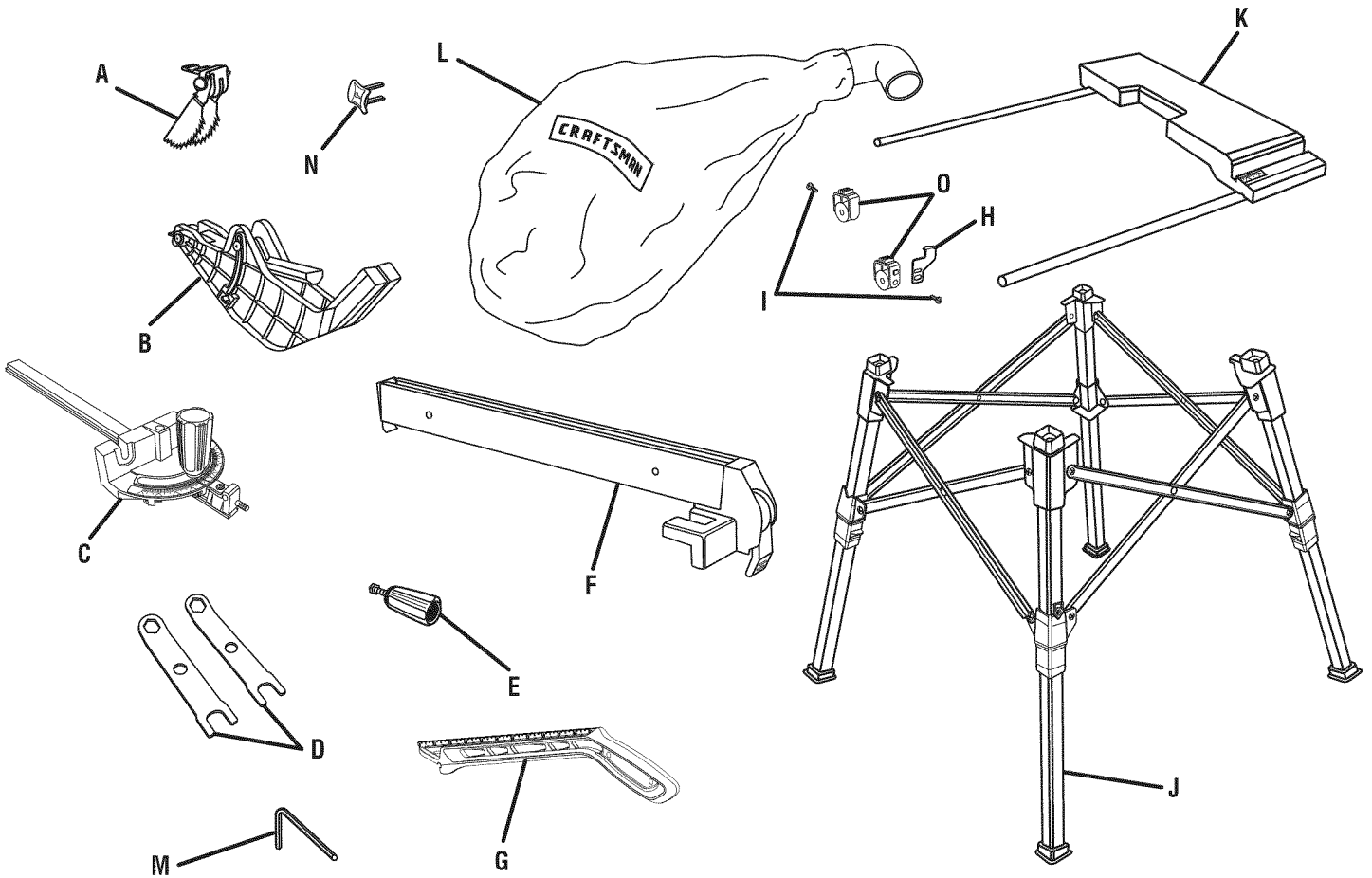

Fig. 5

A. Anti-Kickback Pawls	1	I. Screw	2
B. Blade Guard	1	J. Leg Stand	1
C. Miter Gauge.....	1	K. Sliding Table Assembly.....	1
D. Blade Wrench.....	2	L. Dust Bag	1
E. Handle Assembly	1	M. Hex Key (3 mm, 5 mm).....	2
F. Rip Fence	1	N. Switch Key	1
G. Push Stick	1	O. End Plug	2
H. Indicator	1		

ASSEMBLY

UNPACKING

This product requires assembly.

- Carefully lift saw from the carton and place it on a level work surface.

NOTE: This tool is heavy. To avoid back injury, keep your knees bent and lift with your legs, not your back, and get help when needed.

- ⚠ **WARNING:** Do not use this product if any parts on the Loose Parts List are already assembled to your product when you unpack it. Parts on this list are not assembled to the product by the manufacturer and require customer installation. Use of a product that may have been improperly assembled could result in serious personal injury.

- Inspect the tool carefully to make sure no breakage or damage occurred during shipping.
- Do not discard the packing material until you have carefully inspected the tool, identified all loose parts, and satisfactorily operated the tool.
NOTE: Remove the foam block from between the saw's housing and the motor by first beveling the blade (see page 26).
- The saw is factory set for accurate cutting. After assembling it, check for accuracy. If shipping has influenced the settings, refer to specific procedures explained in this manual.
- If any parts are damaged or missing, please call 1-800-932-3188 for assistance.

- ⚠ **WARNING:** If any parts are damaged or missing, do not operate this tool until the parts are replaced. Use of this product with damaged or missing parts could result in serious personal injury.

- ⚠ **WARNING:** Do not attempt to modify this tool or create accessories not recommended for use with this tool. Any such alteration or modification is misuse and could result in a hazardous condition leading to possible serious personal injury.

- ⚠ **WARNING:** Do not connect to power supply until assembly is complete. Failure to comply could result in accidental starting and possible serious personal injury.

- ⚠ **WARNING:** Do not lift the saw without help. Hold it close to your body. Keep your knees bent and lift with your legs, not your back. Ignoring these precautions can result in back injury.

- ⚠ **WARNING:** Never stand directly in line with the blade or allow hands to come closer than 3 in. to the blade. Do not reach over or across the blade. Failure to heed this warning can result in serious personal injury.

- ⚠ **WARNING:** To avoid serious personal injury, always make sure the table saw is securely mounted to a workbench or an approved leg stand. NEVER operate the saw on the floor.

MOUNTING HOLES

The table saw must be mounted to a firm supporting surface such as a workbench or leg stand. If bolted to a workbench, remove the four locking knobs. Four bolt holes have been provided in the saw's base for this purpose. Each of the four mounting holes should be bolted securely using 3/8 in. machine bolts, lock washers, and hex nuts (not included). Bolts should be of sufficient length to accommodate the saw base, lock washers, hex nuts, and the thickness of the workbench. Tighten all four bolts securely.

Carefully check the workbench after mounting to make sure that no movement can occur during use. If any tipping, sliding, or walking is noted, secure the workbench to the floor before operating.

TO ASSEMBLE THE LEG STAND

See Figures 6 - 7.

NOTE: Do not use this leg stand with other equipment or for other purposes.

- Place the leg stand on the floor.
- Keeping fingers and all body parts away from the stand's moving parts, open the leg stand by pushing opposite legs in opposite directions as indicated by the arrows in figure 6. The stand will be fully opened when the red indicator rests in the V slot of the grip.

NOTE: Only mount the saw when the stand is completely opened.

ASSEMBLY

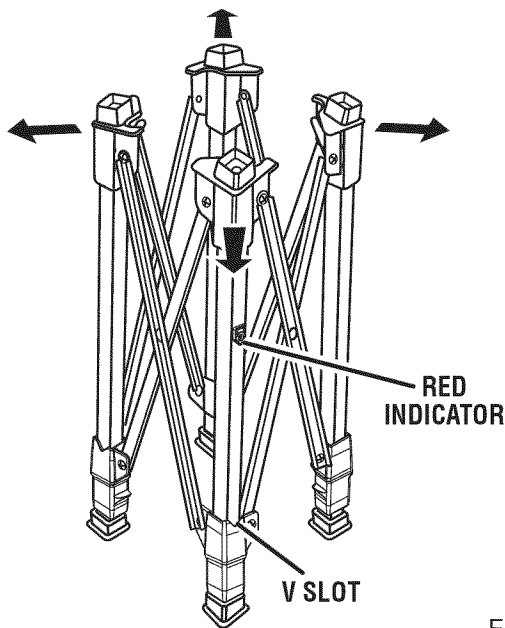

Fig. 6

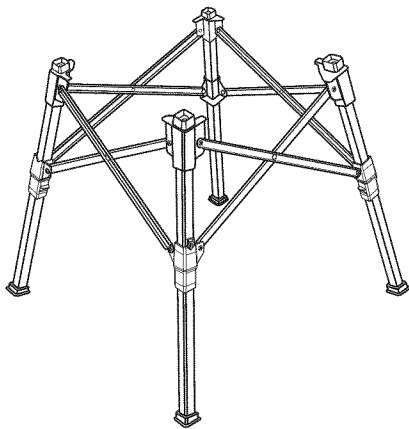

Fig. 7

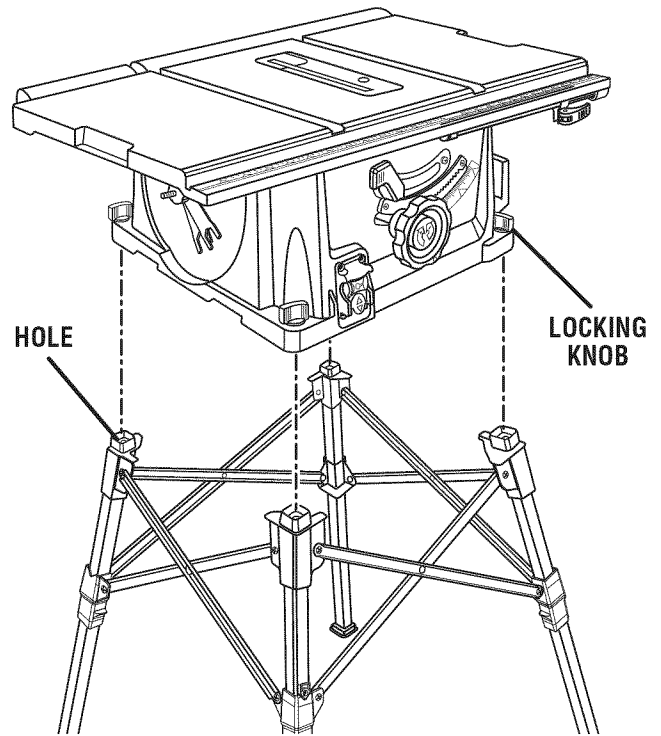

Fig. 8

TO INSTALL THE HANDLE

See Figure 9.

- Hold the nylon nut securely and turn the screw counter-clockwise to remove the nut completely.
NOTE: Do not remove the screw from the handle.
- Place the nylon nut into the recessed hole on the back of the height/bevel adjusting handwheel and hold in place.
- Slide the handle and screw into the hole on the height/bevel adjusting handwheel.
- Using a flathead screwdriver, turn the screw clockwise and tighten in place.

MOUNTING THE TABLE SAW BASE TO THE LEG STAND

See Figure 8.

- Place the table saw base on the leg stand. Position the locking knob over the holes in the top of the leg stand.
- Insert the screw on the locking knob into the hole and turn the locking knob clockwise to secure the table saw base to the leg stand.
- Repeat with the other three locking knobs.

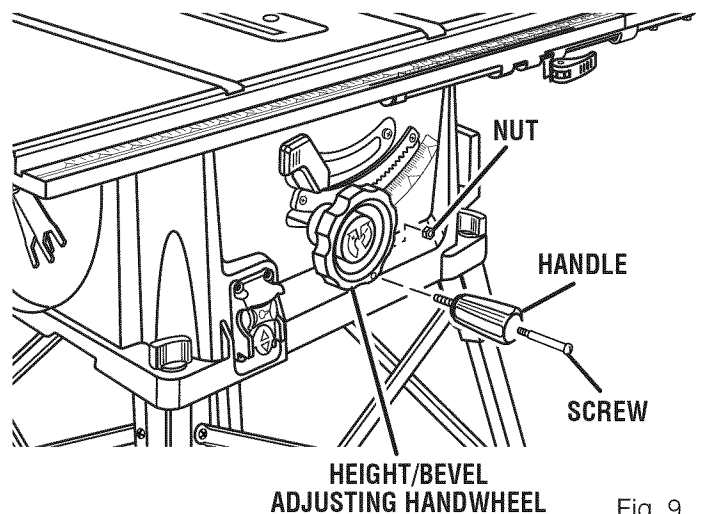

HEIGHT/BEVEL
ADJUSTING HANDWHEEL

Fig. 9

ASSEMBLY

TO REMOVE/REPLACE THE THROAT PLATE

See Figure 10.

- Lower the blade by turning the height/bevel adjusting handwheel counterclockwise.
- To remove the throat plate, place your index finger in the hole and lift the front end pulling the throat plate out toward the front of the saw.
- To reinstall the throat plate, slip the tab into the slot at the back of the saw and push down to secure in place.

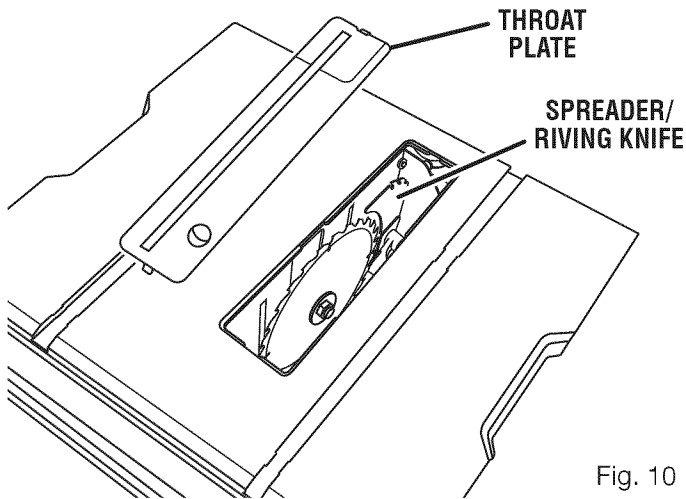

Fig. 10

TO CHANGE BETWEEN A SPREADER AND A RIVING KNIFE

See Figure 11.

This saw is shipped with the spreader/riving knife placed in the non-through cutting or “down” position (riving knife position).

NOTE: The spreader/riving knife must be placed in the through cutting, or “up” position (spreader position), for all other cutting operations.

- Unplug the saw.
- To place in spreader position (or “up” position for all through cutting):
 - Remove the throat plate.
 - Raise the saw blade by turning the height/bevel adjusting handwheel clockwise.
 - Unlock the release lever by pulling it up.
 - Grasp the spreader and pull it towards the right side of the saw to release the spreader from the spring-loaded riving clamp.
 - Pull the spreader up until the internal pins are engaged and the spreader is above the saw blade.
 - Lock the release lever by pushing the lever down.
- Reinstall the throat plate.

To place in riving knife position (or “down” position for all non-through cutting):

- Remove the throat plate.
- Raise the saw blade by turning the height/bevel adjusting handwheel clockwise.
- Unlock the release lever by pulling it up.
- Push the riving knife down until it is below the saw blade.
- Lock the release lever by pushing the lever down.
- Reinstall the throat plate.

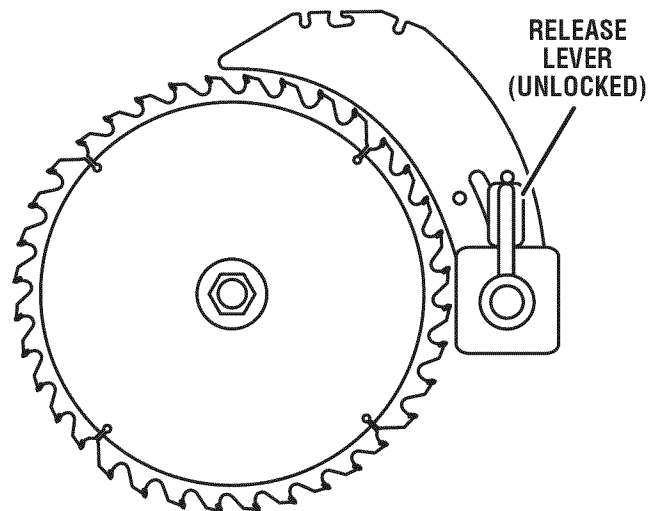

IN “UP” POSITION FOR THROUGH CUTTING

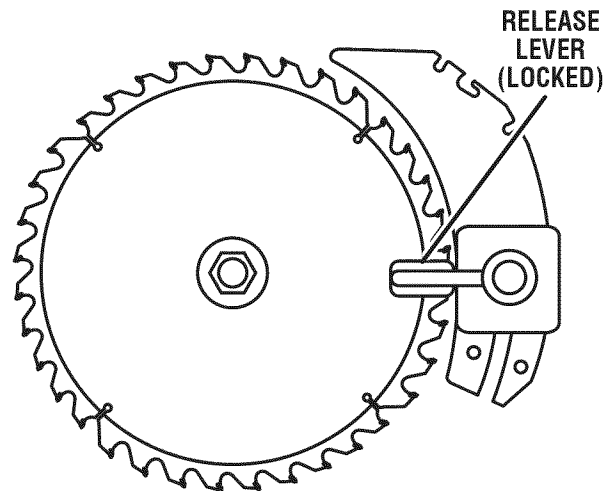

IN “DOWN” POSITION FOR NON-THROUGH CUTTING

Fig. 11

ASSEMBLY

TO CHECK SAW BLADE INSTALLATION

See Figure 12.

CAUTION: To work properly, the saw blade teeth must point down toward the front of the saw. Failure to do so could cause damage to the saw blade, the saw, or the workpiece.

- Unplug the saw.
- Lower the saw blade and remove the throat plate.
- Make sure the bevel locking lever is securely pushed to the left, *see Figure 14*. Raise the saw blade to its full height by turning the height/bevel adjusting handwheel clockwise.
- Place spreader/riving knife in “up” position.

To loosen the blade:

- Remove the blade wrench from the blade wrench storage area.
- Using blade wrenches, place the flat open end of a blade wrench on the flats on the arbor shaft.
- Insert the closed end of the blade wrench over the blade nut. Holding both wrenches firmly, pull the wrench (right side) forward to the front of the machine.

To tighten the blade:

- Using the blade wrench, place the flat open end into the flats on the arbor shaft.
- Insert the closed end of the blade wrench over the blade nut. Holding both wrenches firmly, push the wrench (right side) to the back of the machine. Make sure the blade nut is securely tightened. Do not over-tighten.
- Reinstall the throat plate.
- Check all clearances for free blade rotation.

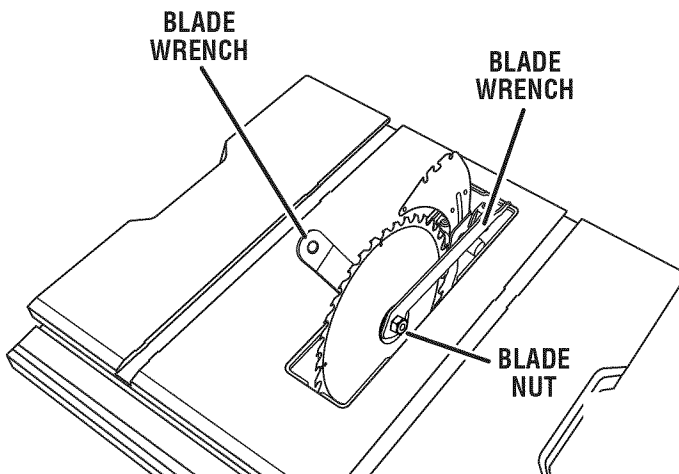

Fig. 12

TO INSTALL THE ANTI-KICKBACK PAWLS AND BLADE GUARD

See Figures 13 - 15.

WARNING: Replace dull or damaged anti-kickback pawls. Dull or damaged pawls may not stop a kick-back increasing the risk of serious personal injury.

Anti-kickback pawls should only be installed for through cuts.

- Unplug the saw.
- Raise the saw blade by turning the height/bevel adjusting handwheel clockwise.
- Place spreader/riving knife in “up” position.

To install anti-kickback pawls:

- Press and hold the button on the right side of the anti-kickback pawls.

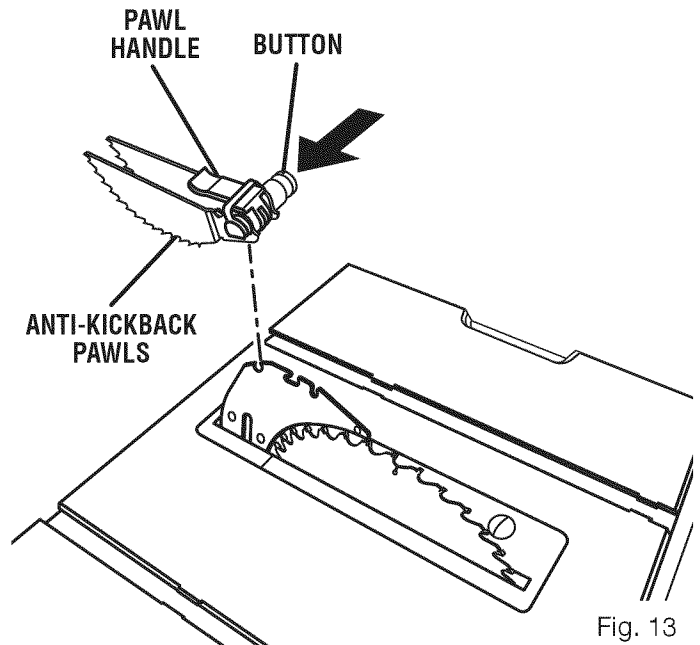

Fig. 13

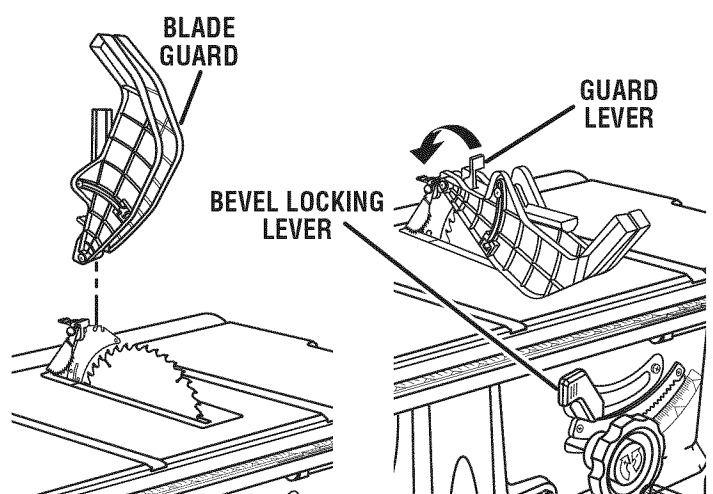

Fig. 14

ASSEMBLY

- Align the slot in the pawls over the rear hole in the spreader/riving knife.
- Push the pawl handle down snapping them into place and release the button.

NOTE: Pull on the pawl handle to make sure pawls are securely locked.

To install blade guard:

- Lift the guard lever up to unlock.
- With the front of the blade guard raised, lower the back of the guard into the middle hole of the spreader/riving knife. Push the front of the guard down until it is parallel to the table (see figure 15). If the blade guard is not parallel to the table, the riving knife is not in the spreader (or “up”) position.
- Lock the guard in place by pushing the guard lever down.

NOTE: Blade alignment with the spreader can be adjusted for different blade widths. Refer to: To Check and Align the Spreader/Riving Knife and Saw Blade. Check the blade guard assembly for clearances and free movement.

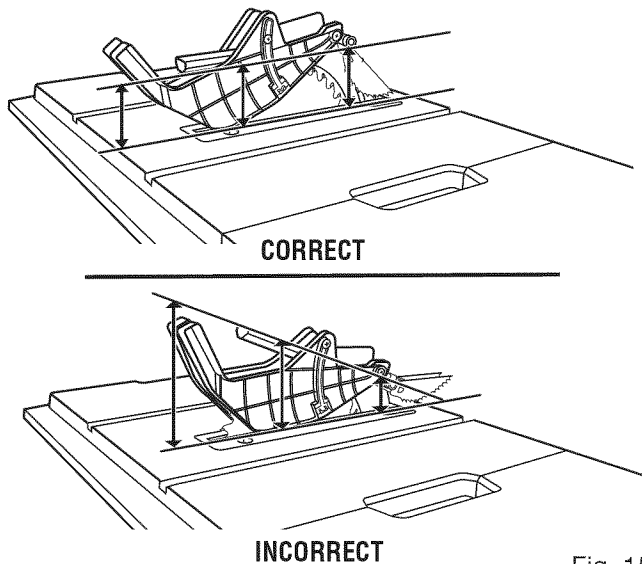

Fig. 15

TO CHECK AND ALIGN THE SPREADER/RIVING KNIFE AND SAW BLADE

See Figure 16.

To check alignment of the spreader/riving knife:

- Unplug the saw.
- Raise the saw blade by turning the height/bevel adjusting handwheel clockwise.
- Remove the anti-kickback pawls and blade guard assembly. Place a framing square or straight edge against both the saw blade and the spreader.

NOTE: Place framing square between carbide teeth and measure from blade. This step will insure framing square is square against blade from the front to back of blade.

- The saw blade and spreader/riving knife are aligned when the framing square contacts both the blade and spreader/riving knife evenly with no gaps.

If the spreader/riving knife is out of alignment with the saw blade, adjustment is needed. The spreader/riving knife must be in alignment front to back (horizontally) and top to bottom (vertically).

To adjust (horizontally):

- Remove the anti-kickback pawls and blade guard assembly.
- Loosen the screws holding the mounting bracket.
- Reposition the spreader/riving knife left or right as needed to align the spreader/riving knife with the saw blade.
- Once properly aligned, securely retighten all screws.

To adjust (vertically):

- Slowly turn the set screws until the riving knife is aligned with the blade.

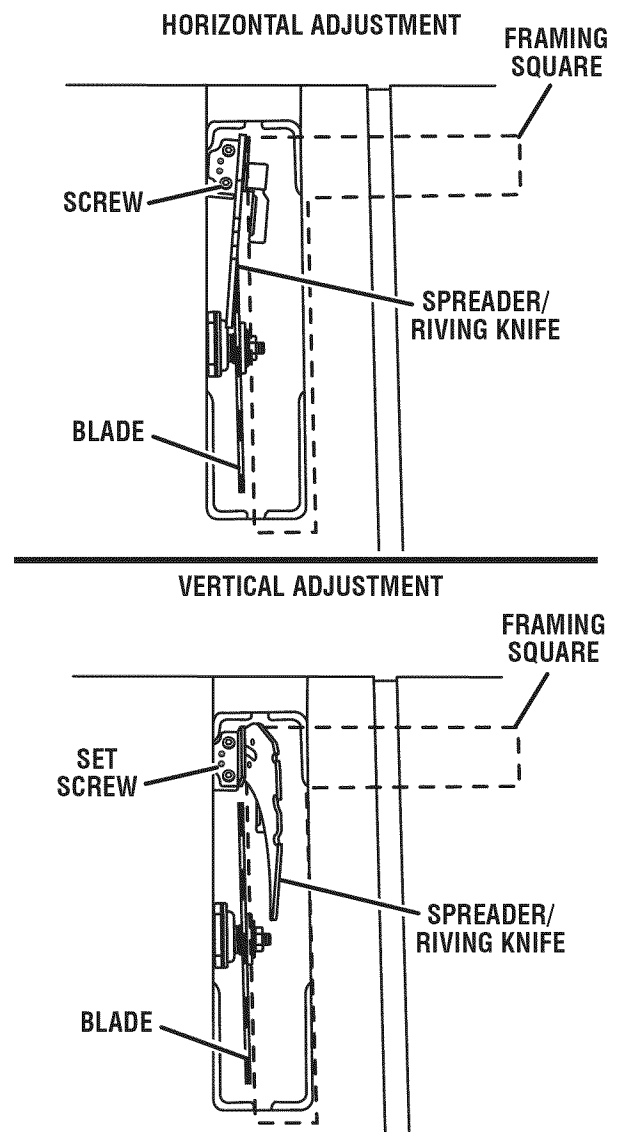

Fig. 16

ASSEMBLY

TO ASSEMBLE THE SLIDING TABLE ASSEMBLY

See Figures 17 - 18.

To install sliding table extension:

- Locate the sliding table assembly.
- Unlock the front and back table locking levers.
- Insert sliding table assembly into table locking levers.
- Push the table assembly until it rests against the saw table and is completely closed.
- Install phillips head screw into hole at end of the rear extension rod to hold sliding table assembly into locking levers.
- Lock the front and back table locking levers.

To install indicator:

- Locate the indicator.
- Slip the indicator in the slot on the front rail. Fit the top slot in the indicator over the detent on the end plug and the bottom slot over the screw hole on the end plug.
- Insert a screw into the bottom slot of the indicator, the hole in the end plug and the extension rod. Tighten securely, but do not overtighten. Overtightening may crush extension rod ends.

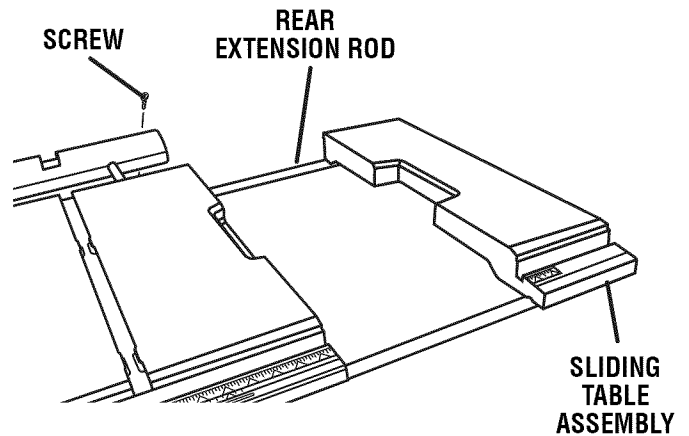

Fig. 17

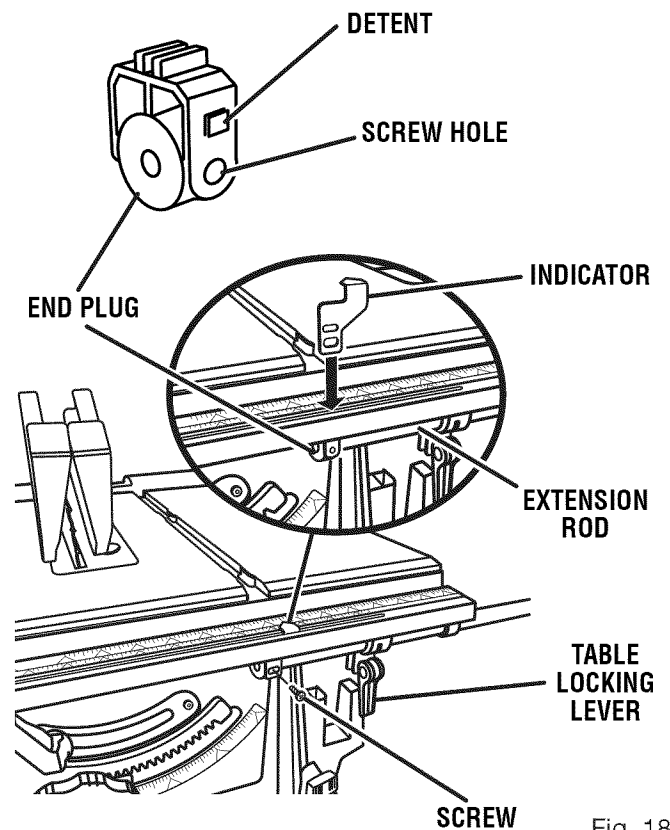

Fig. 18

ASSEMBLY

TO INSTALL DUST BAG

See Figure 19.

- Slide the elbow inside the dust chute on the back of the table saw.

NOTE: For efficient operation, empty the dust bag before it is half full. This will permit better air flow through the bag.

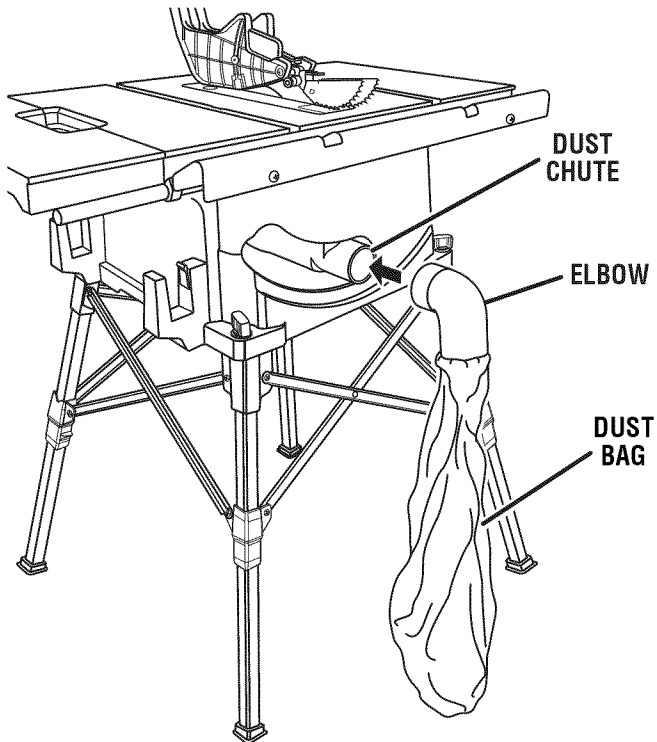

Fig. 19

TO STORE THE TABLE SAW ACCESSORIES

See Figures 20 - 21.

The table saw has two convenient storage areas (one on either side of the saw cabinet) specifically designed for the saw's accessories.

When not in use, store the accessories securely by snapping each accessory in place.

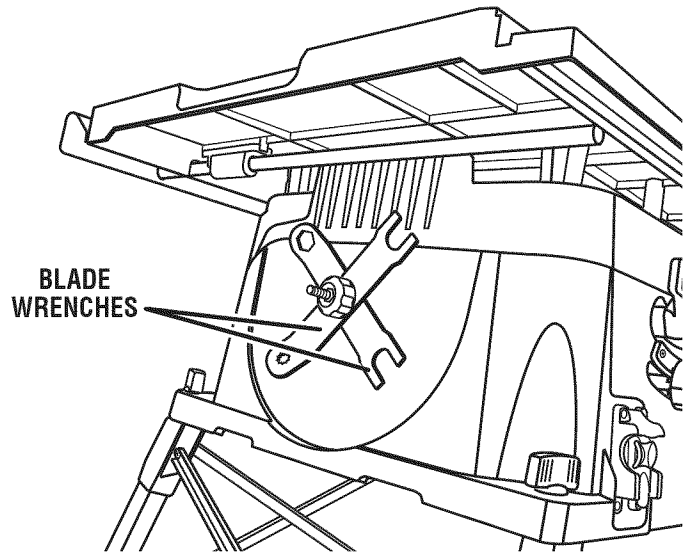

Fig. 20

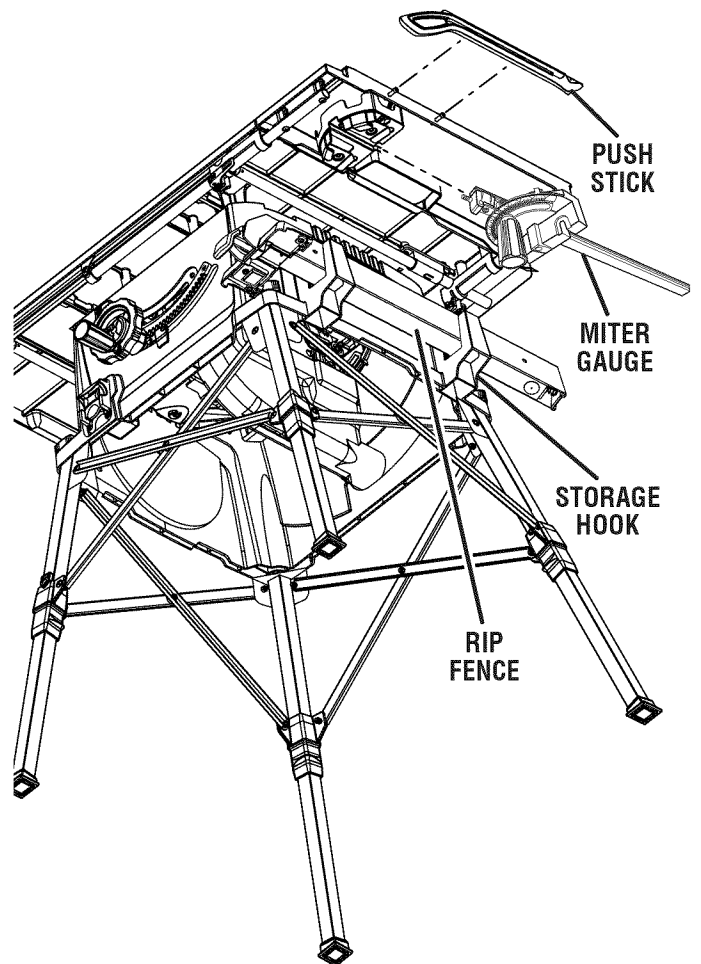

Fig. 21

OPERATION

WARNING: Do not allow familiarity with tools to make you careless. Remember that a careless fraction of a second is sufficient to inflict severe injury.

WARNING: Always wear eye protection with side shields marked to comply with ANSI Z87.1. Failure to do so could result in objects being thrown into your eyes, resulting in possible serious injury.

WARNING: Do not use any attachments or accessories not recommended by the manufacturer of this tool. The use of attachments or accessories not recommended can result in serious personal injury.

WARNING: Although many of the illustrations in this manual are shown with the blade guard removed for clarity, do not operate the saw without the blade guard unless specifically instructed to do so.

APPLICATIONS

You may use this tool for the purposes listed below:

- Straight line cutting operations such as cross cutting, ripping, mitering, beveling, and compound cutting
- Dado with optional accessories
- Cabinet making and woodworking

NOTE: This table saw is designed to cut wood and wood composition products only.

BASIC OPERATION OF THE TABLE SAW

The 3-prong plug must be plugged into a matching outlet that is properly installed and grounded according to all local codes and ordinances. Improper connection of the equipment can result in electric shock. Do not modify the plug if it will not fit the outlet. Have the correct outlet installed by a qualified electrician. Refer to the **Electrical** section in this manual.

CAUSES OF KICKBACK

Kickback can occur when the blade stalls or binds, kicking the workpiece back toward you with great force and speed. If your hands are near the saw blade, they may be jerked loose from the workpiece and may contact the blade. Kickback can cause serious injury. Use precautions to avoid the risks.

Kickback can be caused by any action that pinches the blade in the wood such as:

- Making a cut with incorrect blade depth
- Sawing into knots or nails in the workpiece
- Twisting the wood while making a cut
- Failing to support work
- Forcing a cut
- Cutting warped or wet lumber
- Using the wrong blade for the type of cut
- Not following correct operating procedures
- Misusing the saw
- Failing to use the anti-kickback pawls
- Cutting with a dull, gummed-up, or improperly set blade

AVOIDING KICKBACK

- Always use the correct blade depth setting. The top of the blade teeth should clear the workpiece by 1/8 in. to 1/4 in.
- Inspect the work for knots or nails before beginning a cut. Knock out any loose knots with a hammer. Never saw into a loose knot or nail.
- Always use the rip fence when rip cutting. Use the miter gauge when cross cutting. This helps prevent twisting the wood in the cut.
- Always use clean, sharp, and properly-set blades. Never make cuts with dull blades.
- To avoid pinching the blade, support the work properly before beginning a cut.
- When making a cut, use steady, even pressure. Never force cuts.
- Do not cut wet or warped lumber.
- Use extra caution when cutting some prefinished or composition wood products as the anti-kickback pawls may not always be effective.
- Always guide your workpiece with both hands or with push sticks and/or push blocks. Keep your body in a balanced position to be ready to resist kickback should it occur. Never stand directly in line with the blade.
- Use of a featherboard will help hold the workpiece securely against the saw table or fence.
- Clean the saw, blade guard, under the throat plate, and any areas where saw dust or scrap workpieces may gather.
- Use the right type of blade for the cut being made.
- Always use the spreader / riving knife for every operation where it is allowed. The use of this device will greatly reduce the risk of kickback.

OPERATION

CUTTING AIDS

See Figure 22.

Push sticks are devices that may be used for pushing a workpiece through the blade in any rip cut. When making non-through cuts or ripping narrow stock, always use a push stick, push block, and/or featherboard so your hands do not come within 3 inches of the saw blade. They can be made in various sizes and shapes from scrap wood and used in a specific project. The stick must be narrower than the workpiece, with a 90° notch in one end and shaping for a grip on the other end.

A push block has a handle fastened by recessed screws from the underside. Use push blocks for narrow cuts and all non-through cuts.

CAUTION: Be sure the screws in a push block are recessed to avoid damaging the saw or workpiece.

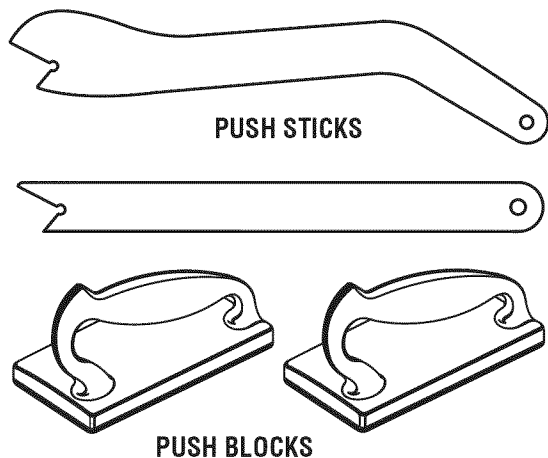

Fig. 22

AUXILIARY FENCE

An auxiliary fence is a device used to close the gap between the rip fence and the saw table. Always make and use an auxiliary fence when ripping material 1/8 in. or thinner.

HOW TO MAKE AND ATTACH AN AUXILIARY FENCE (FOR RIP CUTTING THIN WORKPIECE)

See Figure 23.

Rip fence holes are used to secure an auxiliary fence which requires a piece of wood 3/4 in. thick, 3-1/2 in. wide, and 21 in. long to make.

To attach the auxiliary fence to the rip fence:

- Place the wood against the rip fence and resting firmly on the saw table.
- From the back side of the rip fence, secure the wood to the fence using 1-3/4 in. wood screws.

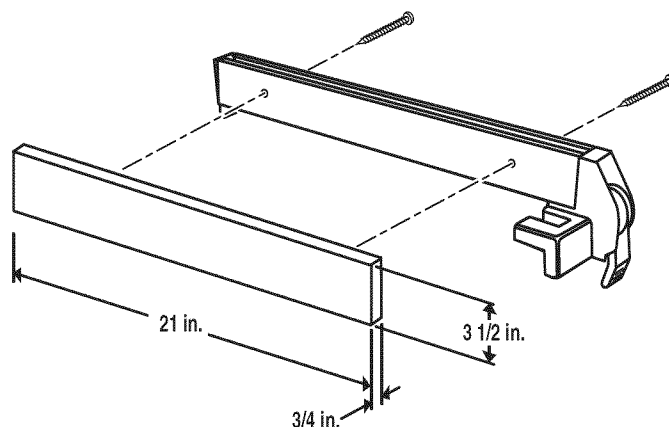

Fig. 23

HOW TO MAKE A JIG (FOR RIP CUTTING NARROW WORKPIECE)

See Figure 24.

If ripping a narrow workpiece places the hands too close to the blade, it will be necessary to make and use a jig.

To make a jig:

- Attach a handle to a long, straight piece of wood and secure from the underside using recessed screws.
- Cut an L-shaped stop in the side of the jig.

To use a jig:

- Position the workpiece flat on the table with the edge flush against the jig and against the stop.
- Holding the jig handle and using a push block and/or push stick, make the rip cut as described on page 31 later in this section.

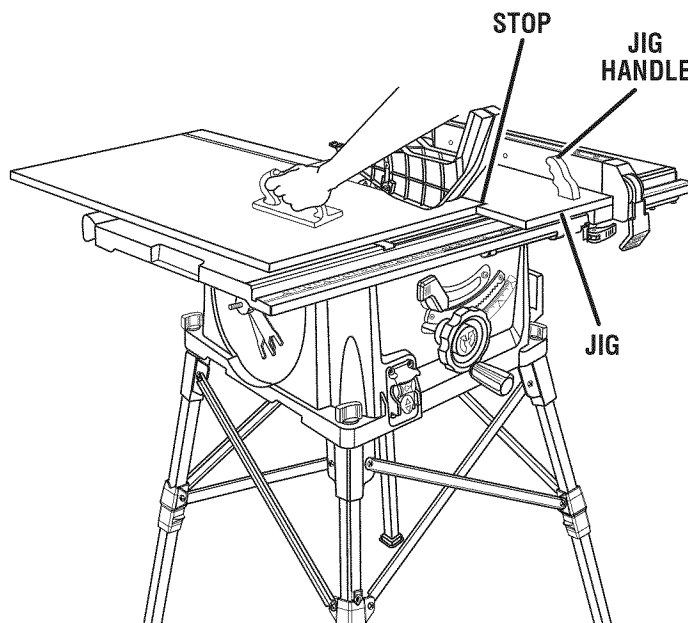

Fig. 24

OPERATION

FEATHERBOARD

A featherboard is a device used to help control the workpiece by holding it securely against the table or fence. Featherboards are especially useful when ripping small workpieces and for completing non-through cuts. The end is angled with a number of short kerfs to give a friction hold on the workpiece and locked in place on the table with a C-clamp. Test to ensure it can resist kickback.

HOW TO MAKE A FEATHERBOARD

See Figure 25.

The featherboard is an excellent project for the saw. Select a solid piece of lumber approximately 3/4 in. thick, 2-1/2 in. wide and 12 in. long. Mark the center of the width on one end of the stock. Miter the width to 70° (see page 31 for information on miter cuts).

Prepare the saw for ripping as discussed on page 31. Set the rip fence to allow approximately a 1/4 in. "finger" to be cut in the stock. Feed the stock only to the mark previously made at 6 in. Turn the saw **OFF** and allow the blade to completely stop rotating before removing the stock. Reset the rip fence and cut spaced rips into the workpiece to allow approximately 1/4 in. fingers and 1/8 in. spaces between the fingers.

⚠ WARNING: Mount the featherboard in front of the saw blade. If positioned improperly, kickback can result from the featherboard pinching the workpiece and binding the blade in the saw kerf. Failure to heed this warning can result in serious personal injury.

HOW TO MOUNT A FEATHERBOARD

See Figure 26.

Completely lower the saw blade. Position the rip fence to the desired adjustment for the cut to be performed and lock. Place the workpiece against the fence and over the saw blade area. Adjust the featherboard to apply resistance to the workpiece just forward of the blade. Securely tighten the adjusting clamp knob to secure the featherboard in place. Attach C-clamps to further secure the featherboard to the edge of the saw table.

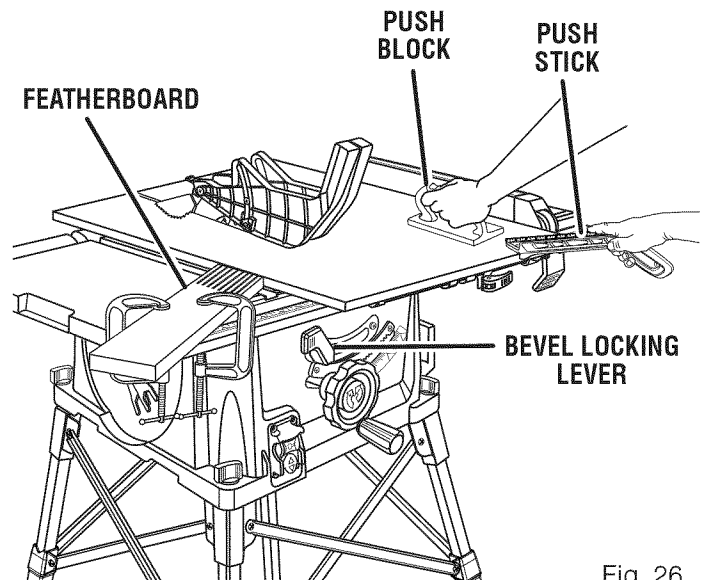

Fig. 26

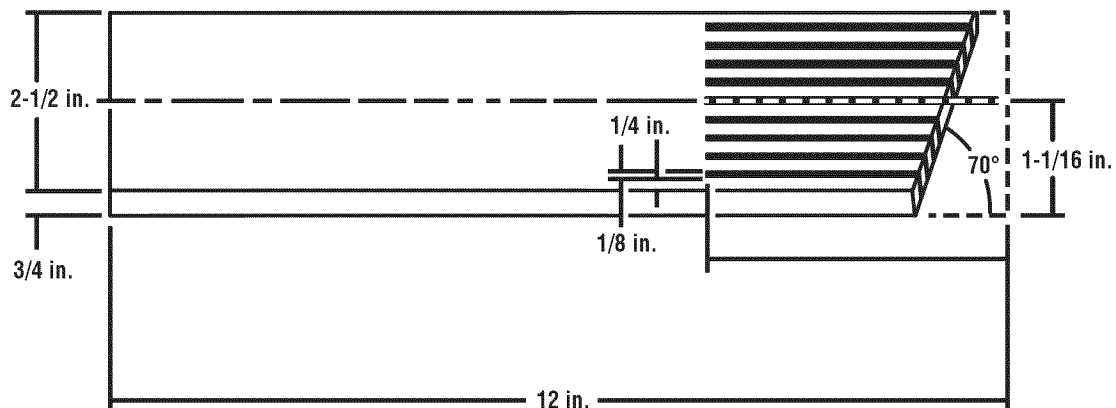

Fig. 25

OPERATION

TYPES OF CUTS

See Figure 27.

There are six basic cuts: 1) the cross cut, 2) the rip cut, 3) the miter cut, 4) the bevel cross cut, 5) the bevel rip cut, and 6) the compound (bevel) miter cut. All other cuts are combinations of these basic six. Operating procedures for making each kind of cut are given later in this section.

⚠ WARNING: Always make sure the blade guard and anti-kickback pawls are in place and working properly when making these cuts to avoid possible injury.

Cross cuts are straight 90° cuts made across the grain of the workpiece. The wood is fed into the cut at a 90° angle to the blade, and the blade is vertical.

Rip cuts are made with the grain of the wood. To avoid kickback while making a rip cut, make sure one side of the wood rides firmly against the rip fence.

Miter cuts are made with the wood at any angle to the blade other than 90°. The blade is vertical. Miter cuts tend to “creep” during cutting. This can be controlled by holding the workpiece securely against the miter gauge.

Bevel cuts are made with an angled blade. Bevel cross cuts are across the wood grain, and bevel rip cuts are with the grain.

Compound (or bevel) miter cuts are made with an angled blade on wood that is angled to the blade. Be thoroughly familiar with making cross cuts, rip cuts, bevel cuts, and miter cuts before trying a compound miter cut.

CUTTING TIPS

Dado and rabbet cuts are non-through cuts which can be either rip cuts or cross cuts. Carefully read and understand all sections of this operator’s manual before attempting any operation.

⚠ WARNING: Do not use blades rated less than the speed of this tool. Failure to heed this warning could result in personal injury.

- The kerf (the cut made by the blade in the wood) will be wider than the blade to avoid overheating or binding. Make allowance for the kerf when measuring wood.
- Make sure the kerf is made on the waste side of the measuring line.
- Cut the wood with the finish side up.
- Knock out any loose knots with a hammer before making the cut.
- Always provide proper support for the wood as it comes out of the saw.

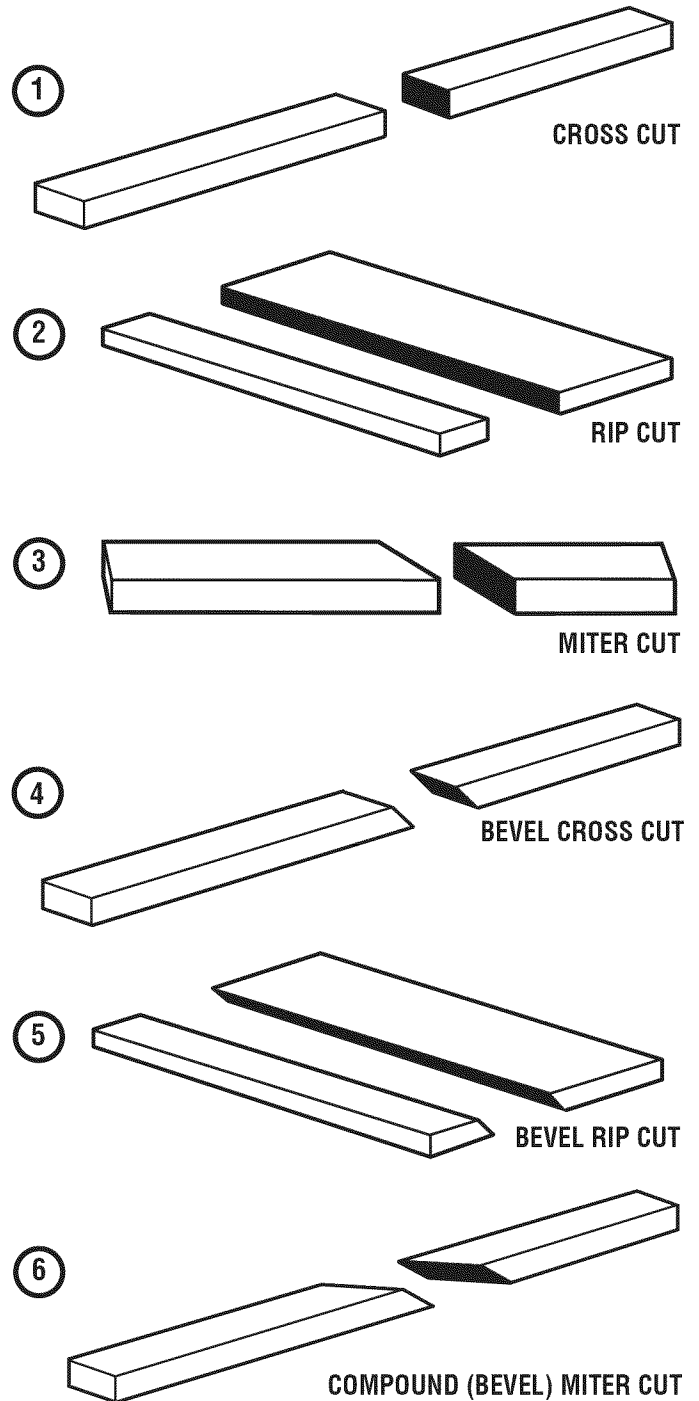

Fig. 27

OPERATION

TO CHANGE BLADE DEPTH

See Figure 28.

The blade depth should be set so that the outer points of the blade are higher than the workpiece by approximately 1/8 in. to 1/4 in. but the lowest points (gullets) are below the top surface.

- Raise the blade by turning the height/bevel adjusting handwheel clockwise or lower it by turning the handwheel counterclockwise.

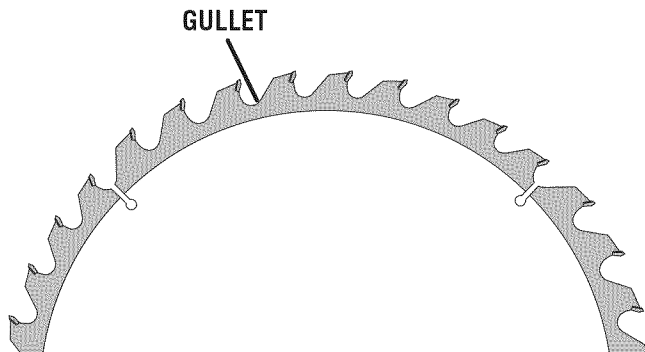

Fig. 28

TO CHANGE BLADE ANGLE (BEVEL)

See Figure 29 - 30.

NOTE: A 90° cut has a 0° bevel and a 45° cut has a 45° bevel.

- Loosen bevel control by pulling the bevel locking lever all the way to the right.
- Adjust the bevel angle by pushing the wheel in toward the saw then turning it. Turning the wheel counterclockwise increases the angle of the blade, bringing it closer to 45°. Turning it clockwise decreases the angle, bringing the blade closer to 90°.
- Tighten bevel control by pushing the bevel lock lever to the left.

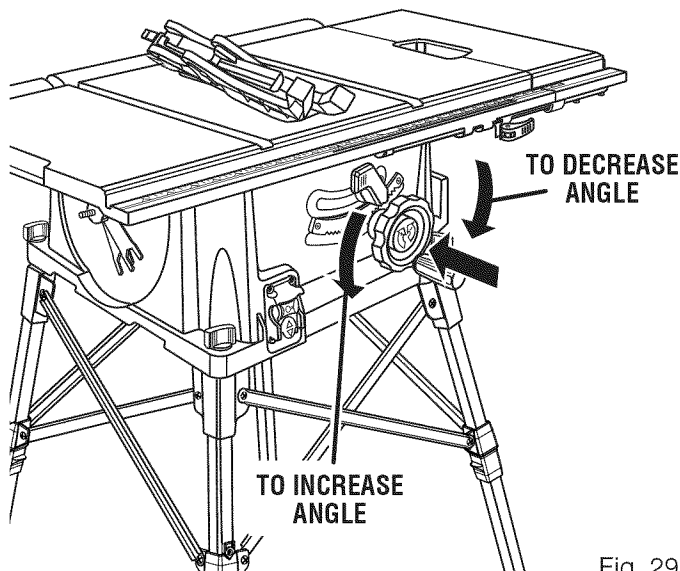

Fig. 29

TO ADJUST THE BEVEL INDICATOR

See Figure 30.

If the bevel indicator is not at zero when the saw blade is at 90°, adjust the indicator by loosening the screw and setting it at 0° on the bevel scale. Retighten the screw.

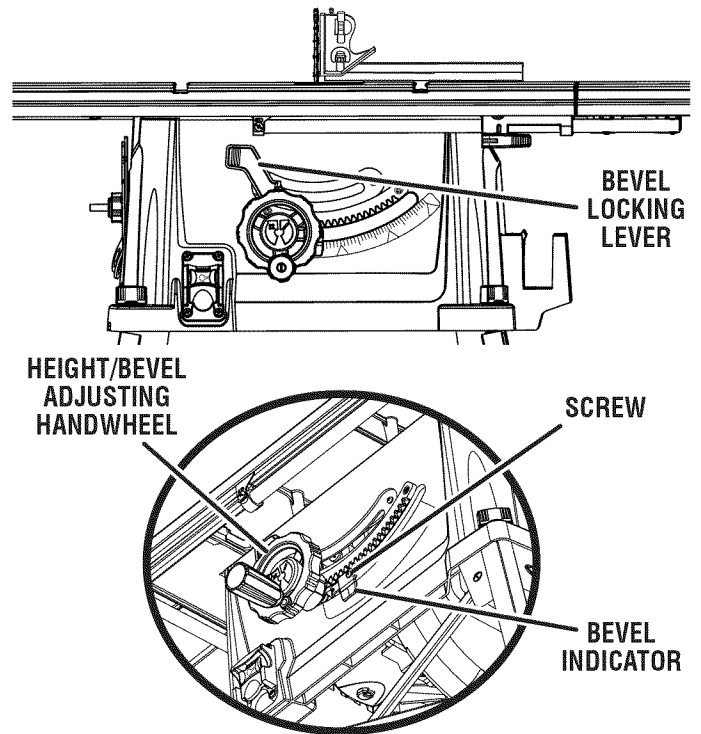

Fig. 30

OPERATION

WARNING: To reduce the risk of injury, always make sure the rip fence is parallel to the blade before beginning any operation.

TO USE THE RIP FENCE

See Figure 31.

- Place the rear lip on the rear of the saw table and pull slightly toward the front of the unit.
- Lower the front end of the rip fence onto the guide surfaces on top of the front rail.
- With the rip fence flat on the saw table, push the fence towards the front rail to align the fence to the saw table.
- Push the locking lever down to align and secure the fence.

Check for a smooth gliding action. If adjustments are needed, see **To Check the Alignment of the Rip Fence to the Blade** in the **Adjustment** section of this manual.

- Make two or three test cuts on scrap wood. If the cuts are not true, repeat the process.

NOTE: The rip fence must be secure when the locking handle is engaged. To increase the grip of the rip fence on the rear lip of the table, tighten the clamp screw on the rear of the rip fence by turning it clockwise.

TO SET THE RIP FENCE SCALE INDICATOR TO THE BLADE

See Figure 31.

Use the indicator on the rip fence to position the fence along the scale on the front rail.

NOTE: The anti-kickback pawls and blade guard assembly must be removed to perform this adjustment. Reinstall the blade guard assembly when the adjustment is complete.

Begin with the blade at a zero angle (straight up).

- Unplug the saw.
- Loosen the rip fence by lifting the locking lever.
- Using a framing square, set the rip fence 2 in. from the blade tip edge.
- Loosen the screw on the scale indicator and align with the 2 in. mark as shown.
- Tighten the screw and check the dimension and the rip fence.

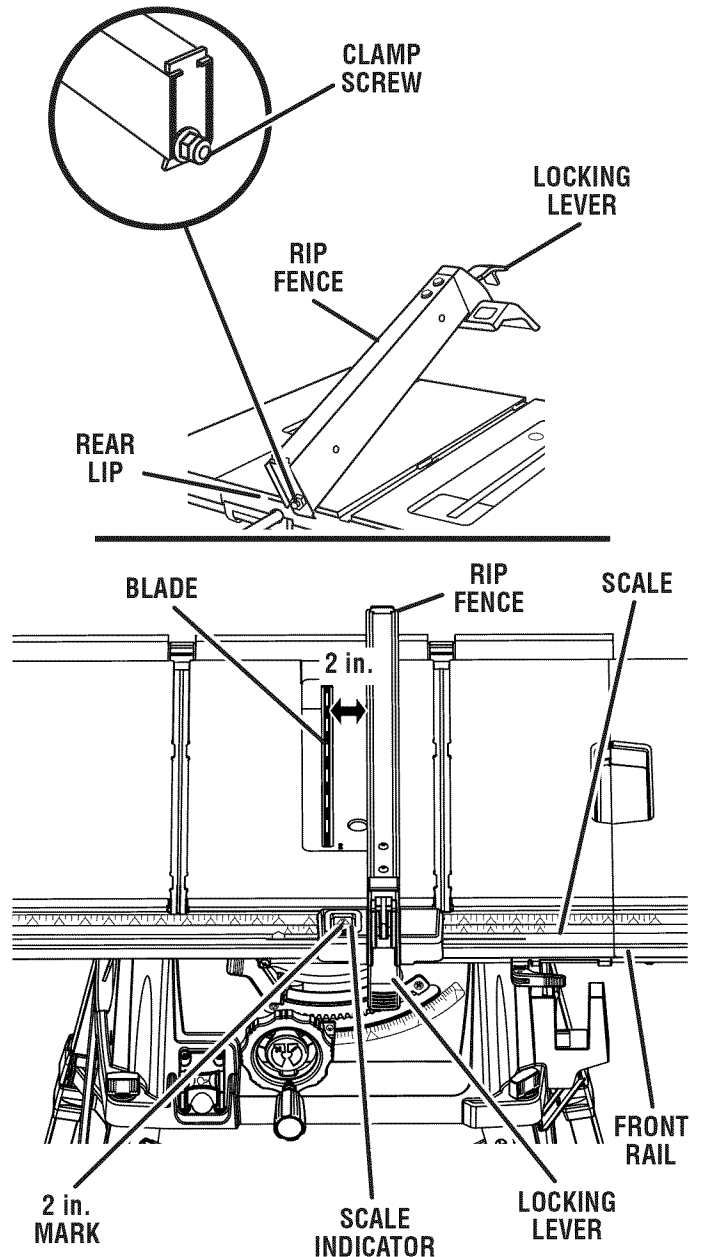

Fig. 31

OPERATION

TO USE THE MITER GAUGE

See Figure 32.

The miter gauge provides greater accuracy in angled cuts. For very close tolerances, test cuts are recommended.

There are two miter gauge grooves, one on either side of the blade. When making a 90° cross cut, you can use either miter gauge groove. When making a beveled cross cut (the blade tilted in relation to the table) the miter gauge should be located in the groove on the right so that the blade is tilted away from the miter gauge and your hands.

The miter gauge can be turned 60° to the right or left.

- Loosen the lock knob.
- With the miter gauge in the miter gauge groove, rotate the gauge until the desired angle is reached on the scale.
- Retighten the lock knob.

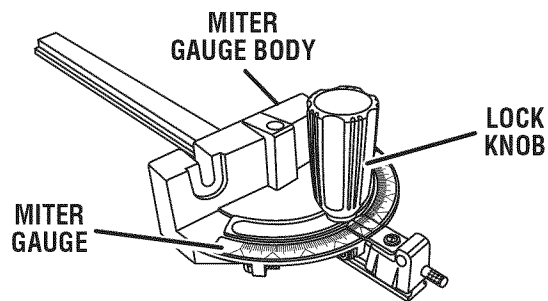

Fig. 32

TO USE THE MITER GAUGE IN A REVERSE POSITION

See Figure 33.

For larger workpieces, the miter gauge can be reversed in the miter gauge grooves. It will be necessary when reversing the miter gauge to securely clamp the workpiece to the miter gauge body.

NOTE: After clamping the wood against the miter gauge face, it must rest flat against both the saw table and miter gauge faces.

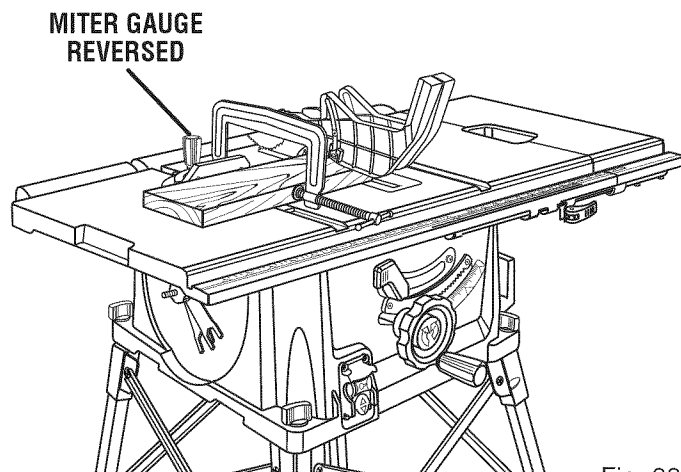

Fig. 33

TO USE THE SLIDING TABLE EXTENSION

See Figure 34.

Increase the length of the saw table by using the table extension.

- Set the rip fence to 15 in.
- Pull the front table locking lever toward you to unlock the lever. Repeat with the back lever.
- Slide the table extension to the desired width.

NOTE: Use the scale on the front rail when a specific width is desired.

- Once the extension table are set to the desired width, relock the front and back locking levers by pushing the levers back towards the saw base.

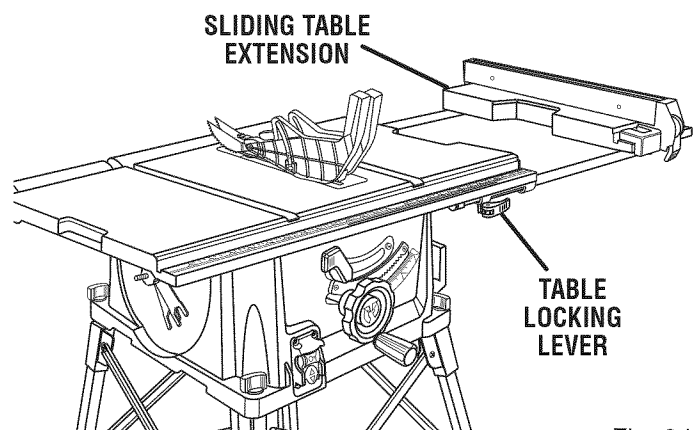

Fig. 34

TO USE THE OUTFEED SUPPORT

See Figure 35.

The outfeed support slides to give the operator additional support for cutting long workpieces.

- With the table saw in the **OFF** position, stand behind the saw.
- Grasp the outfeed support with both hands and pull it until it is fully extended.

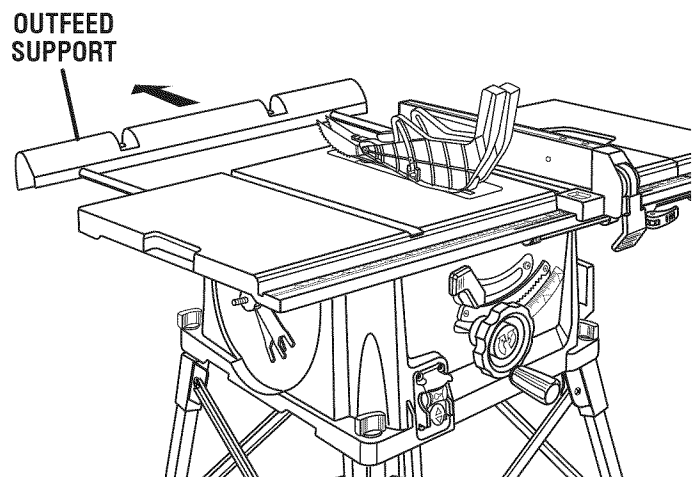

Fig. 35

OPERATION

HEELING (PARALLELING) THE BLADE TO THE MITER GAUGE GROOVE

See Figures 36 - 38.

WARNING: The blade must be parallel to the miter gauge groove so the wood does not bind resulting in kickback. Failure to do so could result in serious personal injury.

Do not loosen any screws for this adjustment until you have checked with a square and made test cuts to be sure adjustments are necessary. Once the screws are loosened, these items must be reset.

- Unplug the saw.
- Remove the blade guard and anti-kickback pawls. Raise the blade by turning the height/bevel adjusting handwheel.
- Mark beside one of the blade teeth at the front of the blade. Place a combination square even with the front of the saw table and the side of the saw blade as shown in figure 36.
- Turn the blade so the marked tooth is at the back.
- Move the combination square to the rear and again measure the distance. If the distances are the same, the blade is square.

If the distances are different:

- Place spreader/riving knife in "down" position.
- Loosen adjusting screws in the front and back of the saw.

NOTE: The adjusting screws are located above the height/bevel adjusting handwheel and under the saw table in the front of the saw.

- If the back of the blade was too far from the combination square, place a block of wood on the left side of the blade and push it into the blade until the blade is square. Retighten the screws.

If the back of the blade was too close to the combination square, place a block of wood on the right side of the blade and push it into the blade until the blade is square.

- Retighten the screws.

WARNING: To reduce the risk of injury from kickback, align the rip fence to the blade following any blade adjustments. Always make sure the rip fence is parallel to the blade before beginning any operation.

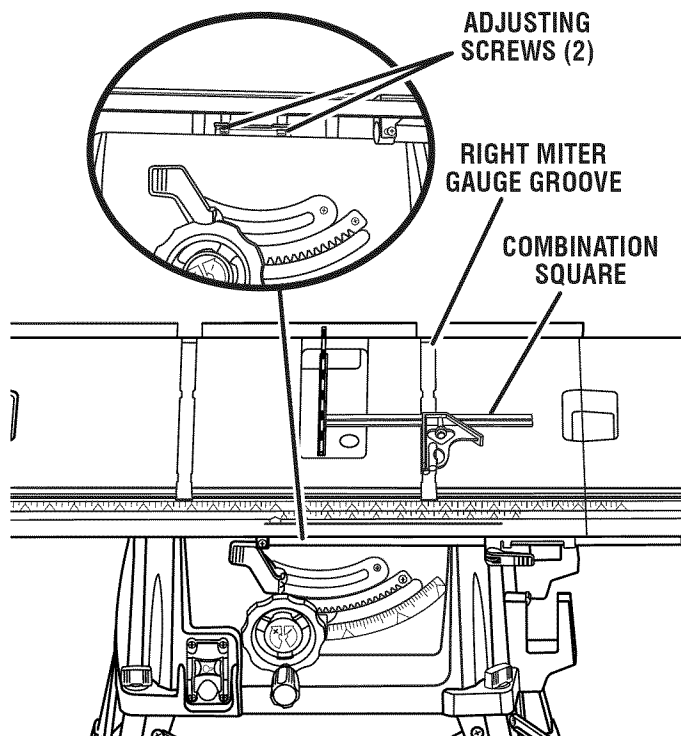

Fig. 36

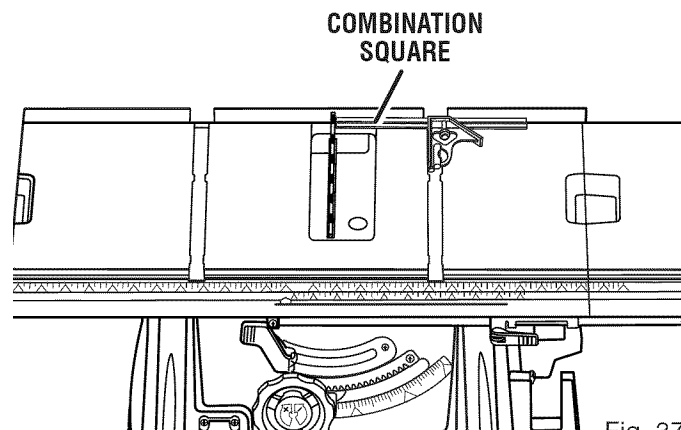

Fig. 37

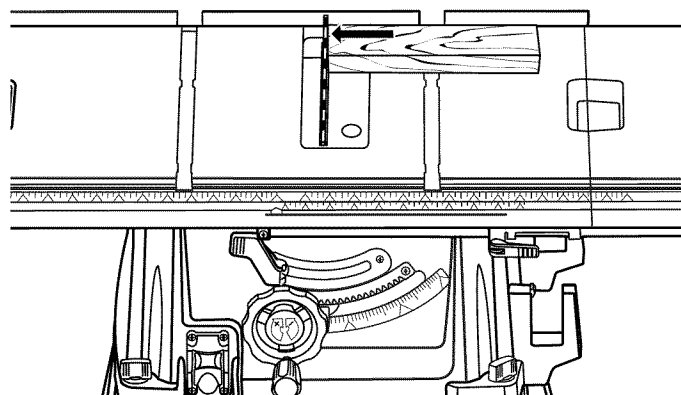

Fig. 38

OPERATION

MAKING CUTS

This table saw can perform a variety of cuts that are not all mentioned in this manual. DO NOT attempt to make any cuts not covered here unless you are thoroughly familiar with the proper procedures and necessary accessories. Your local library has many books on table saw usage and specialized woodworking procedures for your reference.

The blade provided with the saw is a high-quality combination blade suitable for ripping and cross cut operations. Carefully check all setups and rotate the blade one full revolution to assure proper clearance before connecting saw to power source. Stand slightly to the side of the blade path to reduce the chance of injury should kickback occur.

⚠ WARNING: Do not use blades rated less than the speed of this tool. Failure to heed this warning could result in personal injury.

Use the miter gauge when making cross, miter, bevel, and compound miter cuts. To secure the angle, lock the miter gauge in place by twisting the lock knob clockwise. Always tighten the lock knob securely in place before use.

NOTE: It is recommended that you place the piece to be saved on the left side of the blade and that you make a test cut on scrap wood first.

TO MAKE A CROSS CUT

See Figures 39 - 40.

⚠ WARNING: Make sure the blade guard assembly is installed and working properly to avoid serious possible injury.

⚠ WARNING: Using the rip fence as a cutoff gauge when cross cutting will result in kickback which can cause serious personal injury.

- Remove the rip fence.
- Set the blade to the correct depth for the workpiece.
- Set the miter gauge to 0° and tighten the lock knob.
- Make sure the wood is clear of the blade before turning on the saw.
- To turn the saw on, lift the switch button.
- To turn saw off, press the switch button down.

NOTE: To prevent unauthorized use, remove the switch key as shown in figure 40.

- Let the blade build up to full speed before moving the workpiece into the blade.
- Hold the workpiece firmly with both hands on the miter gauge and feed the workpiece into the blade.

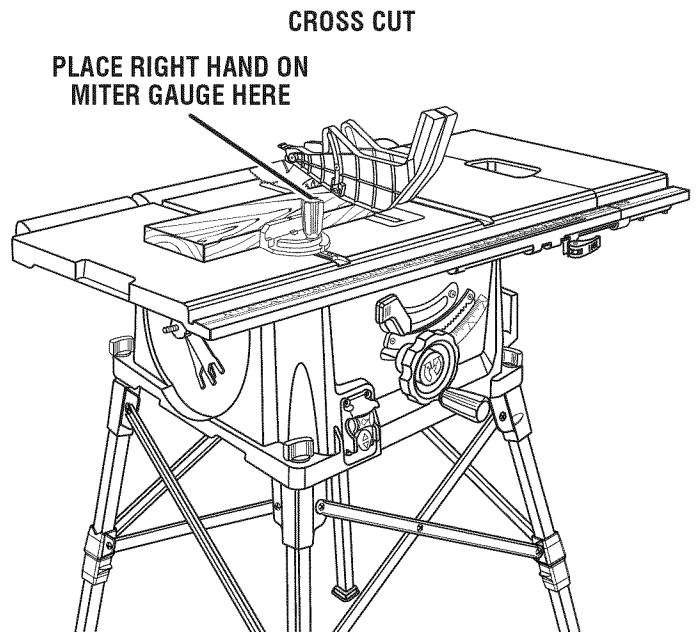
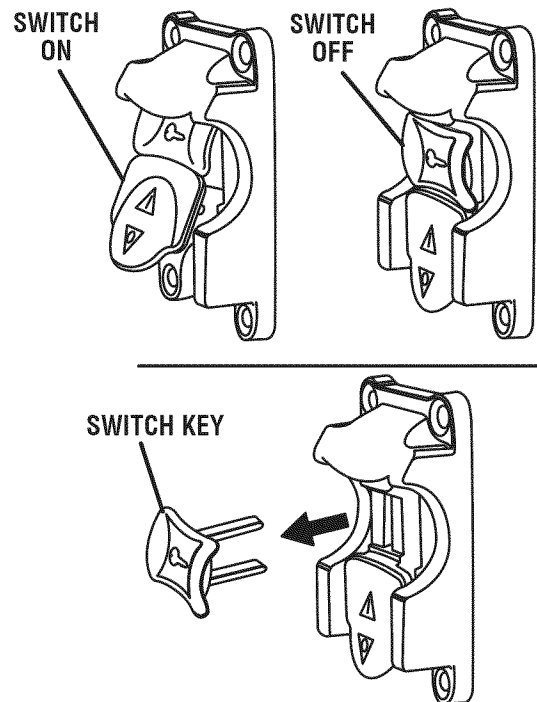

Fig. 39



SWITCH IN LOCKED POSITION

Fig. 40

NOTE: The hand closest to the blade should be placed on the miter gauge lock knob and the hand farthest from the blade should be placed on the workpiece.

- When the cut is made, turn the saw off. Wait for the blade to come to a complete stop before removing the workpiece.

OPERATION

MAKING A RIP CUT

See Figure 41.

- ⚠ **WARNING:** Make sure the blade guard assembly is installed and working properly to avoid serious possible injury.
- Set the blade to the correct depth for the workpiece.
- Position the rip fence the desired distance from the blade for the cut and securely lock the handle.
- Make sure the wood is clear of the blade before turning on the saw.
- When ripping a long workpiece, place a support the same height as the table surface behind the saw for the cut work.
- Turn the saw on.
- Position the workpiece flat on the table with the edge flush against the rip fence. Let the blade build up to full speed before feeding the workpiece into the blade.
- Once the blade has made contact with the workpiece, use the hand closest to the rip fence to guide it. Make sure the edge of the workpiece remains in solid contact with both the rip fence and the surface of the table. If ripping a narrow piece, use a push stick and/or push blocks to move the piece through the cut and past the blade.
- When the cut is made, turn the saw off. Wait for the blade to come to a complete stop before removing the workpiece.

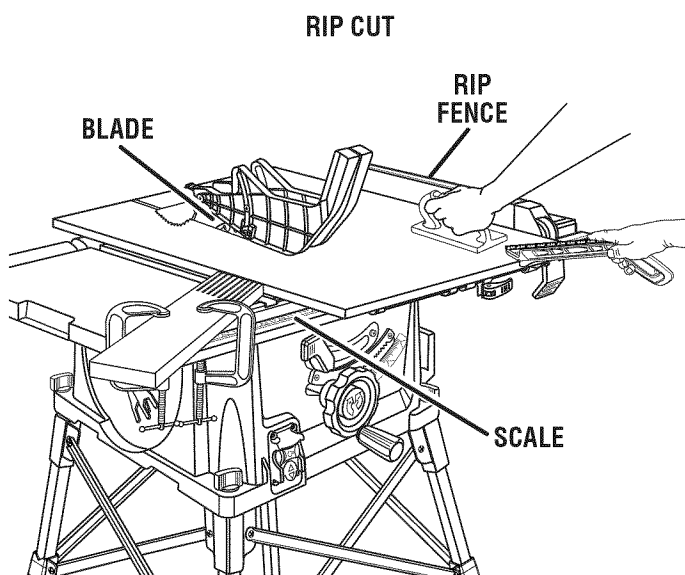

Fig. 41

MAKING A MITER CUT

See Figure 42.

- ⚠ **WARNING:** Make sure the blade guard assembly is installed and working properly to avoid possible serious injury.
- Remove the rip fence.
- Set the blade to the correct depth for the workpiece.
- Set the miter gauge to the desired angle and tighten the lock knob.
- Make sure the wood is clear of the blade before turning on the saw.
- Turn the saw on.
- Let the blade build up to full speed before moving the workpiece into the blade.
- Hold the workpiece firmly with both hands on the miter gauge and feed the workpiece into the blade.
- **NOTE:** The hand closest to the blade should be placed on the miter gauge lock knob and the hand farthest from the blade should be placed on the workpiece.
- When the cut is made, turn the saw off. Wait for the blade to come to a complete stop before removing the workpiece.

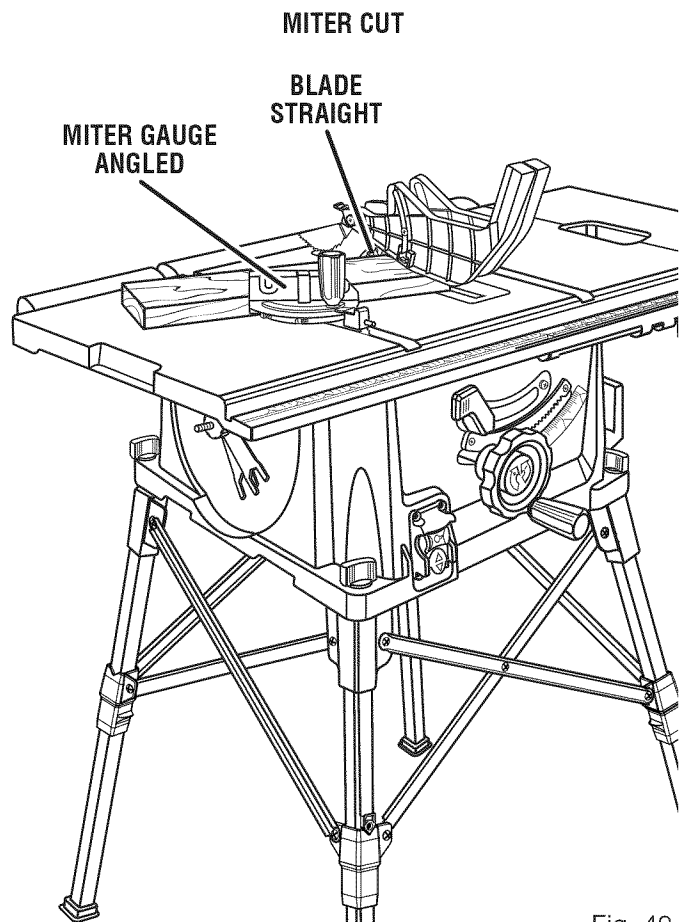

Fig. 42

OPERATION

MAKING A BEVEL CROSS CUT

See Figures 43 - 44.

WARNING: Make sure the blade guard assembly is installed and working properly to avoid possible serious injury.

- Remove the rip fence.
- Unlock the bevel locking lever.
- Adjust the bevel angle to the desired setting.
- Lock the bevel locking lever.
- Set the blade to the correct depth for the workpiece.
- Set the miter gauge to 0° and tighten the lock knob.
- Make sure the wood is clear of the blade before turning on the saw.
- Turn the saw on.
- Let the blade build up to full speed before moving the workpiece into the blade.
- Hold the workpiece firmly with both hands on the miter gauge and feed the workpiece into the blade.

NOTE: The hand closest to the blade should be placed on the miter gauge lock knob and the hand farthest from the blade should be placed on the workpiece.

- When the cut is made, turn the saw off. Wait for the blade to come to a complete stop before removing the workpiece.

VIEWED FROM THE FRONT, BELOW THE TABLE SAW

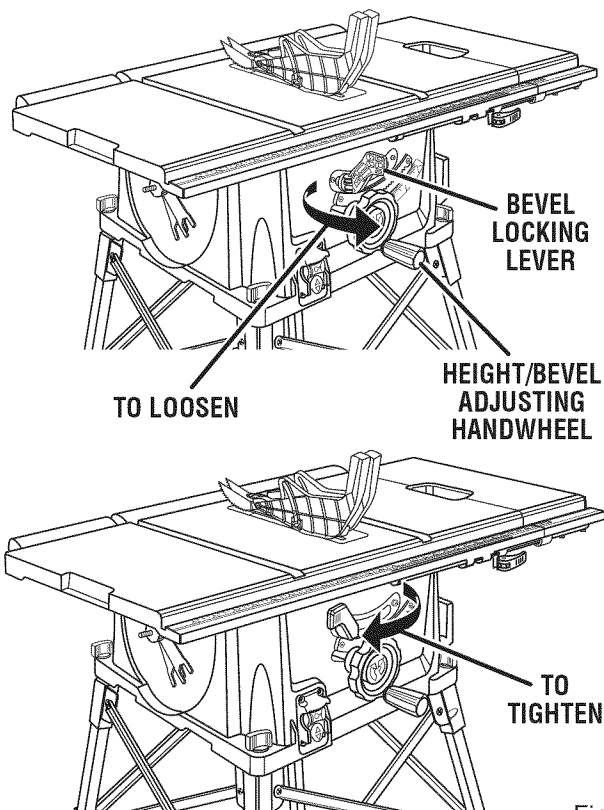

Fig. 43

BEVEL CROSS CUT

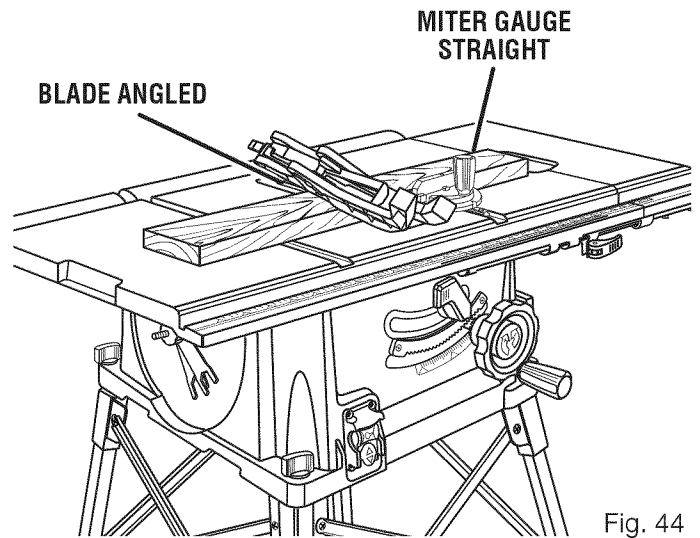

Fig. 44

MAKING A BEVEL RIP CUT

See Figure 45.

WARNING: Make sure the blade guard assembly is installed and working properly to avoid serious personal injury.

WARNING: The rip fence must be on the right side of the blade to avoid trapping the wood and causing kickback. Placement of the rip fence to the left of the blade will result in kickback and the risk of serious personal injury.

- Remove the miter gauge.
- Unlock the bevel locking lever.
- Adjust the bevel angle to the desired setting.
- Lock the bevel locking lever.
- Set the blade to the correct depth for the workpiece.
- Position the rip fence the desired distance from the blade for the cut and securely lock the handle.
- Make sure the wood is clear of the blade before turning on the saw.
- When ripping a long workpiece, place a support the same height as the table surface behind the saw for the cut work.
- Turn the saw on.

OPERATION

- Position the workpiece flat on the table with the edge flush against the rip fence. Let the blade build up to full speed before feeding the workpiece into the blade.
- Once the blade has made contact with the workpiece, use the hand closest to the rip fence to guide it. Make sure the edge of the workpiece remains in solid contact with both the rip fence and the surface of the table. If ripping a narrow piece, use a push stick and/or push blocks to move the piece through the cut and past the blade.
- When the cut is made, turn the saw off. Wait for the blade to come to a complete stop before removing the workpiece.

BEVEL RIP CUT

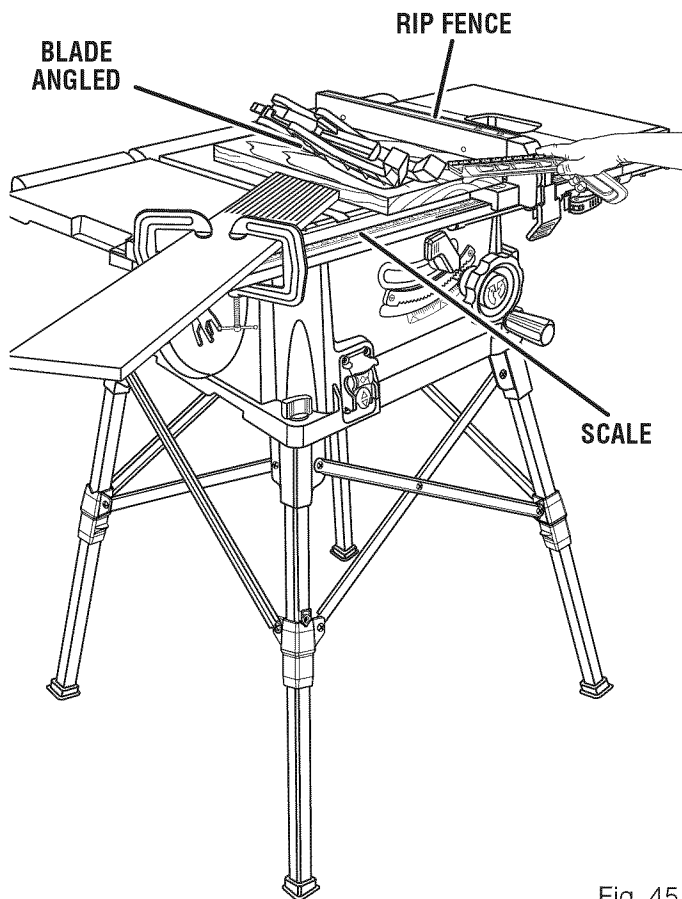

Fig. 45

MAKING A COMPOUND (BEVEL) MITER CUT

See Figure 46.

WARNING: Make sure the blade guard assembly is installed and working properly to avoid possible serious injury.

- Remove the rip fence.
- Unlock the bevel locking lever.
- Adjust the bevel angle to the desired setting.

- Lock the bevel locking lever.
- Set the blade to the correct depth for the workpiece.
- Set the miter gauge to the desired angle and tighten the lock knob.
- Make sure the wood is clear of the blade before turning on the saw.
- Turn the saw on.
- Let the blade build up to full speed before moving the workpiece into the blade.
- Hold the workpiece firmly with both hands on the miter gauge and feed the workpiece into the blade.
NOTE: The hand closest to the blade should be placed on the miter gauge lock knob and the hand farthest from the blade should be placed on the workpiece.
- When the cut is made, turn the saw off. Wait for the blade to come to a complete stop before removing the workpiece.

COMPOUND (BEVEL) MITER CUT

PLACE LEFT HAND ON MITER GAUGE HERE

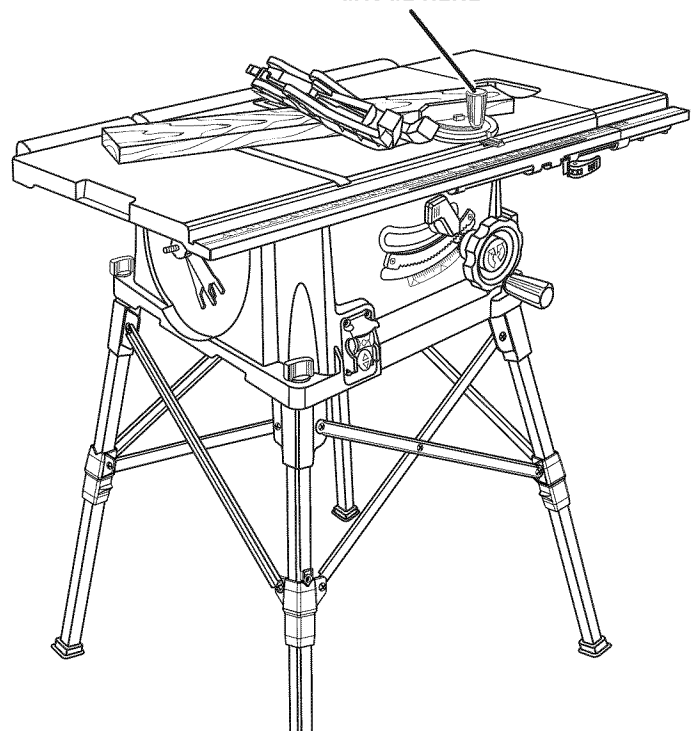

Fig. 46

OPERATION

MAKING A LARGE PANEL CUT

See Figure 47.

Make sure the saw is properly secured to a work surface to avoid tipping from the weight of a large panel.

- ▲ **WARNING:** Make sure the blade guard assembly is installed and working properly to avoid possible serious injury.
- ▲ **WARNING:** Never make freehand cuts (cuts without the miter gauge or rip fence). Unguided workpieces can result in serious injury.
- Place a support the same height as the top of the saw table behind the saw for the cut work. Add supports to the sides as needed.
- Depending on the shape of the panel, use the rip fence or miter gauge. If the panel is too large to use either the rip fence or the miter gauge, it is too large for this saw.
- Make sure the wood does not touch the blade before you turn on the saw.
- Turn the saw on.
- Position the workpiece flat on the table with the edge flush against the rip fence. Let the blade build up to full speed before feeding the workpiece into the blade.
- Use a push stick to move the piece through the cut and past the blade.
- When the cut is made, turn the saw off. Wait for the blade to come to a complete stop before removing the workpiece.

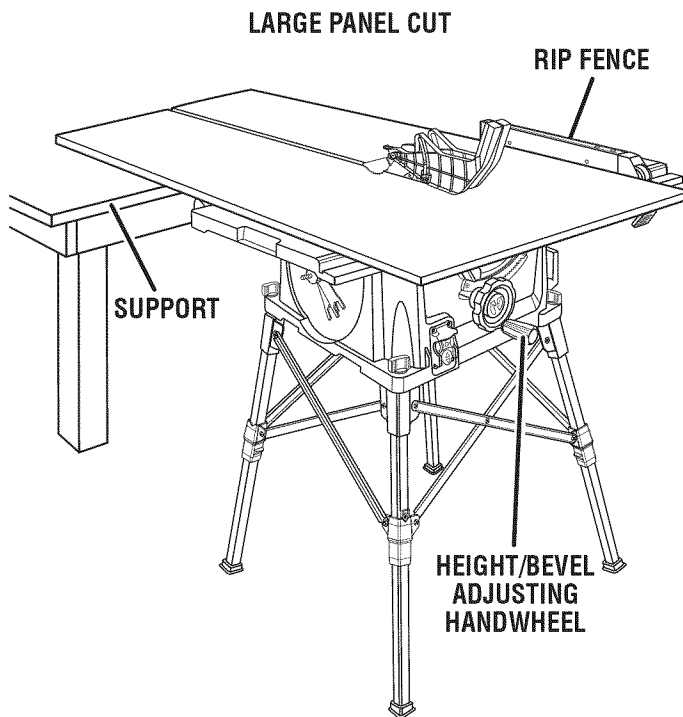

Fig. 47

MAKING A NON-THROUGH CUT

See Figure 48.

Non-through cuts (made with a standard 10 in. blade) can be made with the grain (ripping) or across the grain (cross cut). The use of a non-through cut is essential to cutting grooves, rabbets, and dados. This is the only type cut that is made without the blade guard assembly installed. Make sure the blade guard assembly is reinstalled upon completion of this type of cut. Read the appropriate section which describes the type of cut in addition to this section on non-through or dado cuts. For example, if your non-through cut is a straight cross cut, read and understand the section on straight cross cuts before proceeding.

- ▲ **WARNING:** When making a non-through cut, the blade is covered by the workpiece during most of the cut. Be alert to the exposed blade at the start and finish of every cut to reduce the risk of personal injury.
 - ▲ **WARNING:** Never feed wood with your hands when making any non-through cut such as rabbets or dados. To avoid personal injury, always use push blocks, push sticks, and featherboards.
 - Unplug the saw.
 - Remove the blade guard and anti-kickback pawls.
 - Place spreader/riving knife in “down” position.
 - Unlock the bevel locking lever.
 - Adjust the bevel angle to 0°.
 - Lock the bevel locking lever.
 - Set the blade to the correct depth for the workpiece.
 - Depending on the shape and size of the wood, use either the rip fence or miter gauge.
 - Plug the saw into the power source and turn the saw on.
 - Let the blade build up to full speed before moving the workpiece into the blade.
 - Always use push blocks, push sticks, and/or featherboards when making non-through cuts to reduce the risk of serious injury.
 - When the cut is made, turn the saw off. Wait for the blade to come to a complete stop before removing the workpiece.
- Once all non-through cuts are completed:**
- Unplug your saw.
 - Reinstall the spreader/riving knife in the “up” position then install the blade guard and anti-kickback pawls.

OPERATION

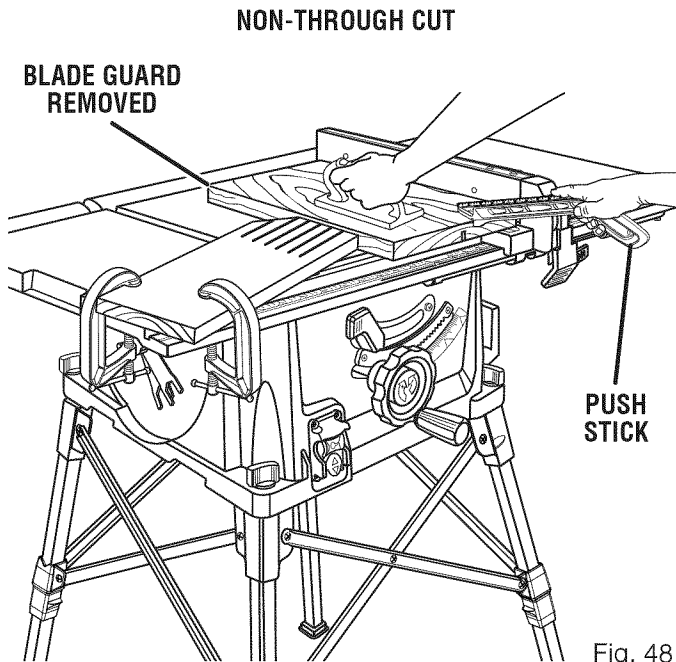

Fig. 48

- Make sure the blade nut is fully engaged and the arbor extends past a securely tightened blade nut.
- Place release lever in locked position.
- Install the dado throat plate and rotate the blade by hand to make sure it turns freely then lower the blade.
- Depending on the shape and size of the wood, use either the rip fence or miter gauge.
- Turn the saw on.

NOTE: Make sure the wood does not touch the blade before you turn on the saw. Let the blade build up to full speed before feeding the workpiece into the blade.

- Position the workpiece flat on the table with the edge flush against the rip fence or miter gauge and hold firmly against the saw table.
- Use a push block or push stick to move the wood through the cut past the blade. Never push a small piece of wood into the blade with your hand, always use a push stick. The use of push blocks, push sticks, and featherboards are necessary when making non-through cuts.
- When the cut is made, turn the saw off. Wait for the blade to come to a complete stop before removing the workpiece.

Once all dado cuts are completed:

- Unplug your saw.
- Reinstall the spreader/riving knife in the “up” position then install the blade guard and anti-kickback pawls.

MAKING A DADO CUT

See Figure 49.

An optional dado throat plate is required for this procedure (see the **Accessories** section of this manual). All blades and dado sets must not be rated less than the speed of this tool. This saw is designed for 5/8 in. dado cuts. With the purchase of an optional dado throat plate, it can be used with a 6 in. stack dado (up to width of 3/4 in.). Do not use an adjustable dado or molding cutters on this saw.

WARNING: Always use push blocks, push sticks, and/or featherboards when making dado cuts to avoid the risk of serious injury.

- Unplug the saw.
- Remove the blade guard, anti-kickback pawls, throat plate, and spreader/riving knife.
- Remove the blade nut, blade washer, saw blade, and inner blade washer.
- Install the special blade washer included with the dado throat plate (purchased separately).
- Mount the dado blade, according to manufacturer instructions, using the blade and chippers appropriate for the desired width of cut.
- Reinstall the blade nut.

NOTE: The blade washer may be used provided the arbor shaft extends slightly beyond the arbor nut.

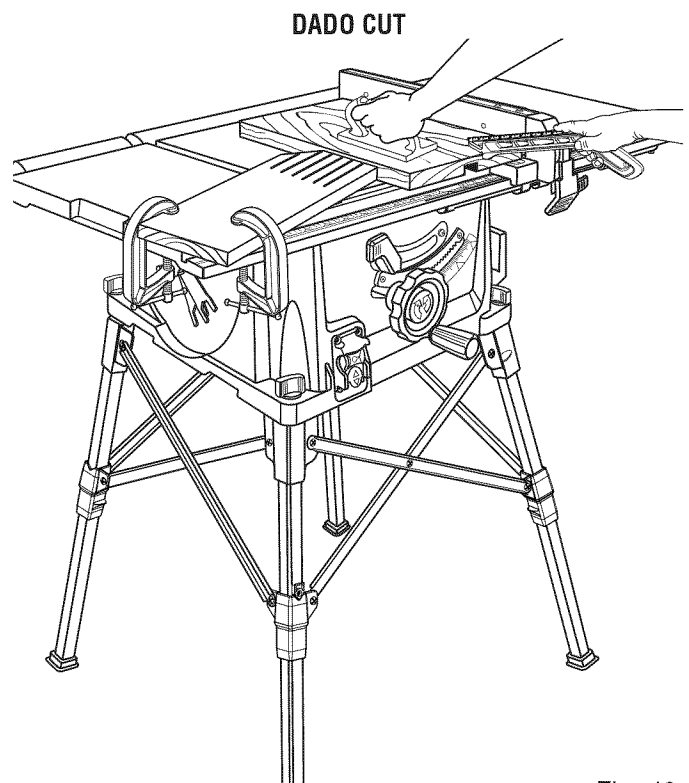

Fig. 49

ADJUSTMENTS

⚠ WARNING: Before performing any adjustment, make sure the tool is unplugged from the power supply and the switch is in the **OFF** position. Failure to heed this warning could result in serious personal injury.

The table saw has been adjusted at the factory for making very accurate cuts. However, some of the components might have been jarred out of alignment during shipping. Also, over a period of time, readjustment will probably become necessary due to wear.

To avoid unnecessary set-ups and adjustments, a good practice is to check your setups carefully with a framing square and make practice cuts in scrap wood before making finish cuts in good workpieces. Do not start any adjustments until you have checked with a square and made test cuts to be sure adjustments are needed.

TO REPLACE THE BLADE

See Figures 50 - 52.

- Unplug the saw.
- Remove the blade guard and anti-kickback pawls.
- Lower the saw blade and remove the throat plate.
- Make sure the bevel locking lever is locked.
- Raise the saw blade to full height.
- Insert the open end of the blade wrench onto the flats on the arbor shaft.
- Insert the closed end of the blade wrench over the blade nut. Holding both wrenches firmly, pull the outside wrench (right side) forward while pushing the inside (left side) to the back of the saw. Remove the nut and blade washer.
- Unlock the release lever and remove the blade.

To install a standard blade:

- Place the new blade on the arbor shaft (the teeth must point down toward the front of the saw to work properly).
- Place the blade washer and the blade nut over the arbor shaft. Be sure the dome side of the blade washer faces the blade and that all items are snug against the arbor housing. Make sure the blade nut is securely tightened. Do not overtighten.
- Lock the release lever.
- Rotate the blade by hand to make sure it turns freely.
- Lower the saw blade and reinstall the throat plate.

NOTE: To replace the blade with an accessory blade, follow the instructions provided with the accessory.

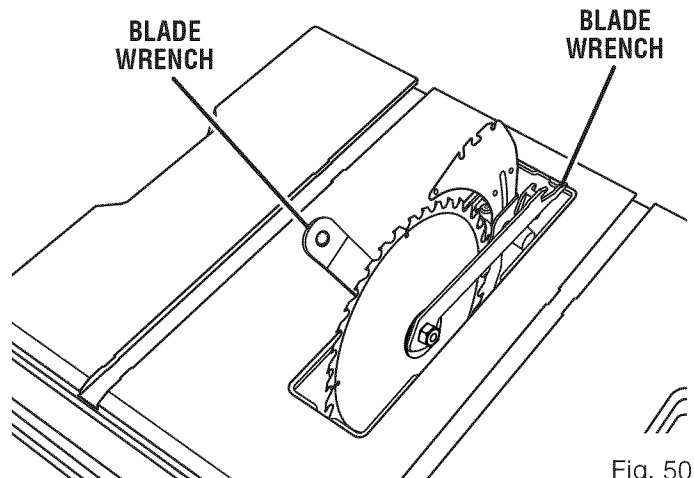

Fig. 50

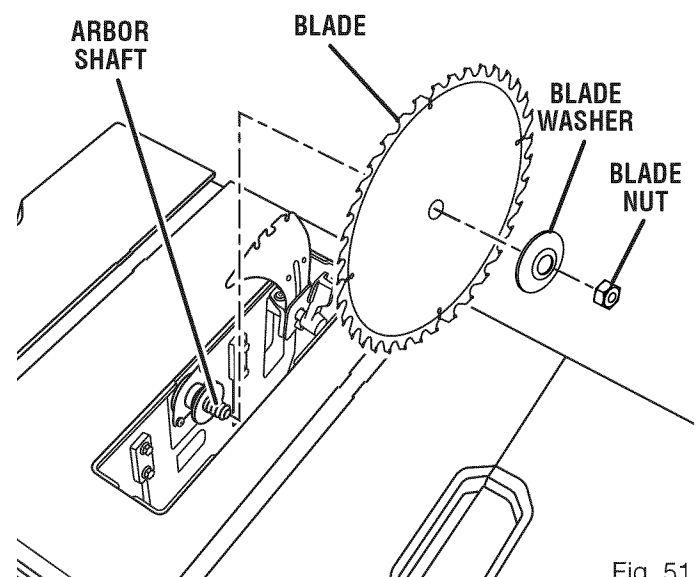

Fig. 51

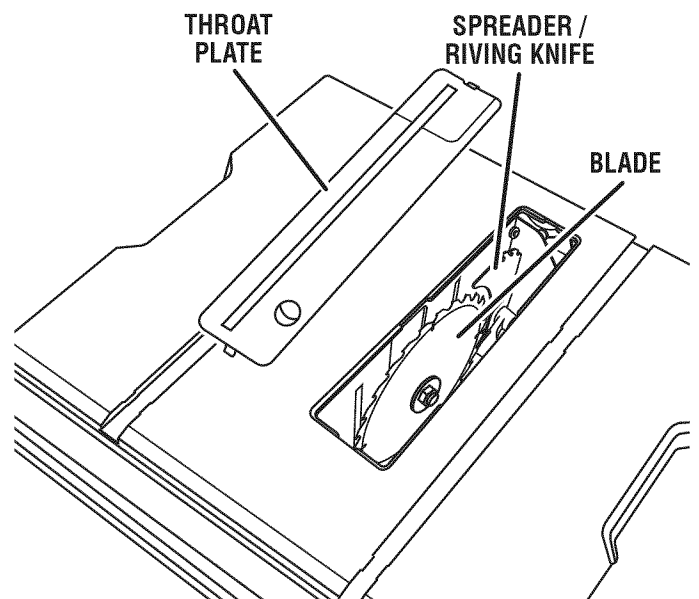

Fig. 52

ADJUSTMENTS

TO ADJUST THE MITER GAUGE

See Figure 53.

You can set the miter gauge at 0° and plus or minus 45° with the miter gauge stop pin and adjustable stop screws.

NOTE: The miter gauge provides close accuracy in angled cuts. For very close tolerances, test cuts are recommended.

- Loosen knob and pull out on stop pin to rotate miter gauge base past stop screws.
- Loosen the lock nut of the 0° stop screw at the stop pin with a 8 mm wrench.
- Place a 90° square against the miter gauge rod and the miter gauge base.
- If the rod is not square, loosen the knob, adjust the rod, and tighten the knob.
- Adjust the 0° stop screw until it rests against the stop pin.
- Adjust the plus and minus 45° stop screws using a 45° triangle and the steps above.

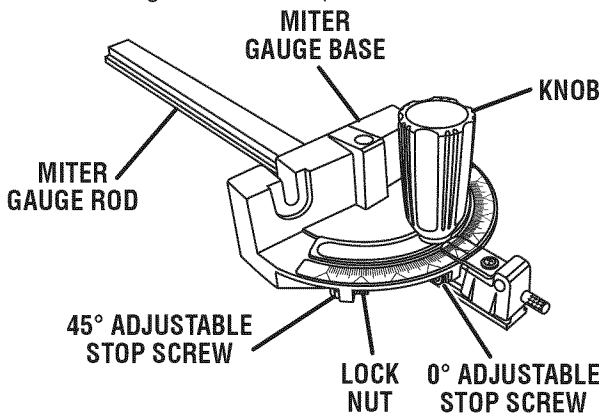

Fig. 53

TO SET THE BLADE AT 0° AND 45°

See Figures 54 - 55.

The angle settings of the saw have been set at the factory and, unless damaged in shipping, should not require setting during assembly. After extensive use, they may need to be checked.

- Unplug the saw.
- Raise the blade.

If the blade is not perfectly vertical (0°):

- Loosen the adjustment screw and the bevel locking lever.
- Place a combination square beside the blade on the left. Lock the angle by pushing the bevel locking lever down and retighten the adjustment screw.
- Turn the handle until the bevel indicator points to zero. If the handle is turned as far as possible and doesn't indicate zero properly, you may need to adjust the bevel indicator.

NOTE: It will be necessary to remove the handle to adjust the bevel indicator.

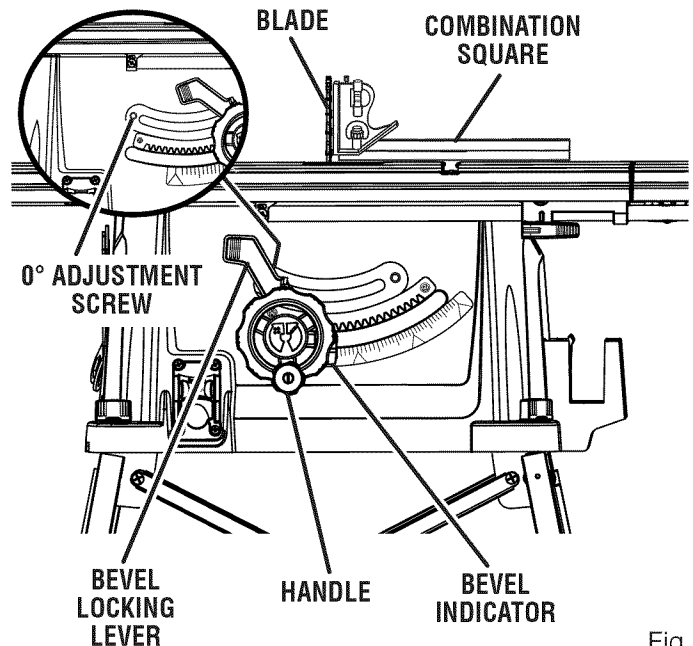

Fig. 54

If the blade is not an exact 45°:

- Loosen the adjustment screw and the bevel locking lever.
- Place a combination square beside the blade on the left.
- Turn the handle until the bottom of the blade has moved completely to the left side of the slot. Lock the angle by pushing the bevel locking lever.
- If the blade is not an exact 45°, loosen the 45° adjustment screw and the bevel locking lever.
- Adjust the bevel indicator to 45°.
- Make a test cut.

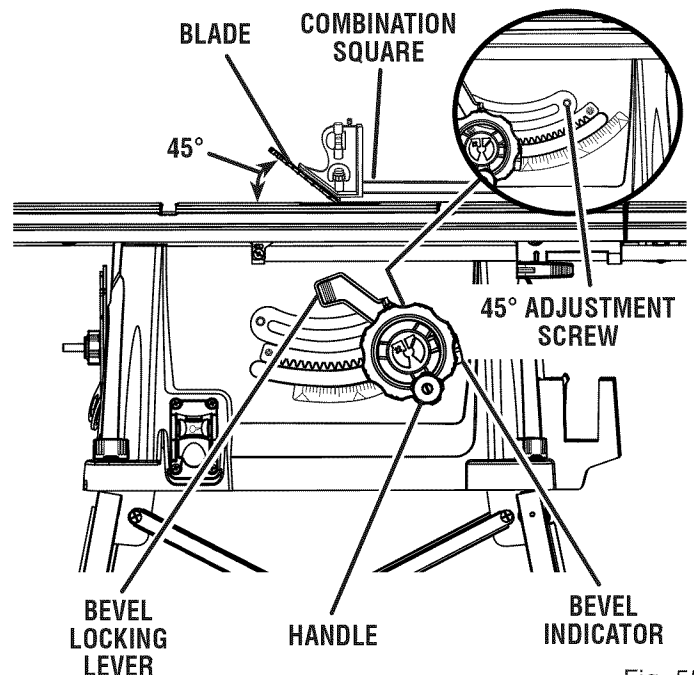

Fig. 55

ADJUSTMENTS

TO CHECK THE ALIGNMENT OF THE RIP FENCE TO THE BLADE

See Figure 56.

- Unplug the saw.
- Raise the locking lever to permit the rip fence to be moved.
- Place a framing square beside the blade and move the rip fence up to the square. Take the dimension on the rip scale.
- Move the fence back and turn the framing square 180° to check the other side.
- If the two dimensions are not the same, loosen the two bolts on the fence and align it.
- Retighten the two bolts.
- Make two or three test cuts on scrap wood. If the cuts are not true, repeat the process.

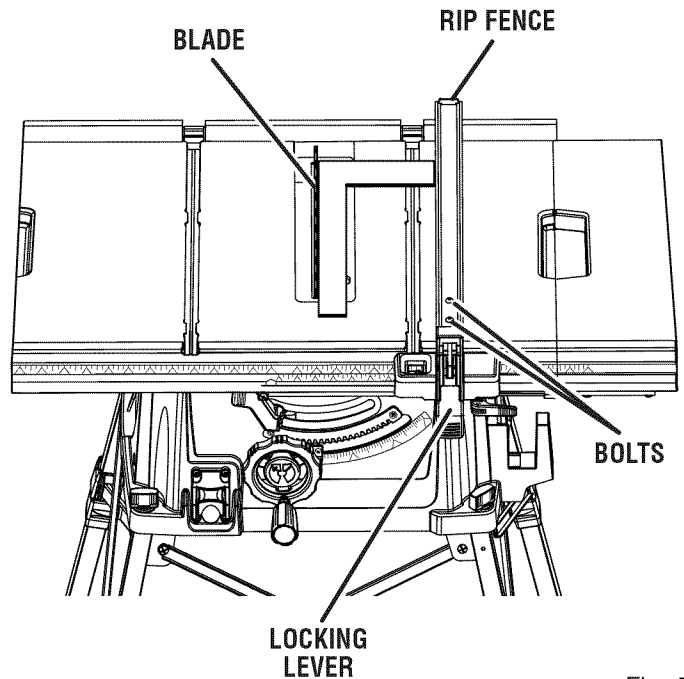

Fig. 5

MAINTENANCE

WARNING: When servicing, use only identical replacement parts. Use of any other parts may create a hazard or cause product damage.

WARNING: Always wear eye protection with side shields marked to comply with ANSI Z87.1 during product operation. If operation is dusty, also wear a dust mask.

WARNING: Before performing any maintenance, make sure the tool is unplugged from the power supply and the switch is in the off (O) position. Failure to heed this warning could result in serious personal injury.

GENERAL MAINTENANCE

Avoid using solvents when cleaning plastic parts. Most plastics are susceptible to damage from various types of commercial solvents and may be damaged by their use. Use clean cloths to remove dirt, dust, oil, grease, etc.

WARNING: Do not at any time let brake fluids, gasoline, petroleum-based products, penetrating oils, etc., come in contact with plastic parts. Chemicals can damage, weaken, or destroy plastic which may result in serious personal injury.

- Periodically check all clamps, nuts, bolts, and screws for tightness and condition. Make sure the throat plate is in good condition and in position.
- Check the blade guard assembly.
- To maintain the table surfaces, fence, and rails, periodically apply paste wax to them and buff to provide smooth functioning.
- Protect the blade by cleaning out sawdust from underneath the table and in the blade teeth. Use a resin solvent on the blade teeth.
- Clean plastic parts only with a soft damp cloth. DO NOT use any aerosol or petroleum solvents.

LUBRICATION

All of the bearings in this tool are lubricated with a sufficient amount of high grade lubricant for the life of the unit under normal operating conditions. Therefore, no further lubrication is required.

ACCESSORIES

The following recommended accessories are currently available at retail stores:

089037008711 Dado Throat Plate with Special Washer

⚠ WARNING: Current attachments and accessories available for use with this tool are listed above. Do not use any attachments or accessories not recommended by the manufacturer of this tool. The use of attachments or accessories not recommended can result in serious personal injury.

TROUBLESHOOTING

PROBLEM	CAUSE	SOLUTION
Excess vibration.	Blade is out of balance.	Replace blade.
	Blade is damaged.	Replace blade.
	Saw is not mounted securely.	Tighten all hardware.
	Work surface is uneven.	Reposition on flat surface. Adjust legs of optional stand.
	Blade is warped.	Check saw blade installation. Replace blade if necessary.
Rip fence does not move smoothly.	Rip fence not mounted correctly.	Remount the rip fence.
	Rails are dirty or sticky.	Clean and wax rails.
	Clamp screw is out of adjustment.	Adjust clamp screw counterclockwise.
Rip fence does not lock at rear.	Clamp screw is out of adjustment.	Adjust clamp screw clockwise.
Cutting binds or burns work.	Blade is dull.	Replace or sharpen blade.
	Blade is heeling.	See page 29 on "Heeling the Blade".
	Work is fed too fast.	Slow the feed rate.
	Rip fence is misaligned.	Align the rip fence.
	Wood is warped.	Replace the wood. Always cut with convex side to table surface.
	Spreader is out of alignment.	See "To check and align the spreader/riving knife and saw blade" in the Assembly section.
Wood edges away from rip fence when ripping.	Blade not properly sharpened or set.	Resharpen or set blade.

TROUBLESHOOTING

PROBLEM	CAUSE	SOLUTION
Saw does not make accurate 90° or 45° cuts.	Positive stops inside cabinet need adjusting (Bevel Cuts).	Adjust positive stops.
	Miter gauge is misaligned (Miter Cuts).	Adjust the miter gauge.
Height/bevel adjusting hand-wheel is hard to turn.	Gears or screw post inside cabinet are clogged with saw dust.	Clean the gears or screw post.
Saw does not start.	Motor cord or wall cord is not plugged in.	Plug in motor cord or wall cord.
	Circuit fuse is blown.	Replace circuit fuse.
	Circuit breaker is tripped.	Reset circuit breaker.
	Cord or switch is damaged.	Have the cord or switch replaced at your nearest authorized service center.
Blade makes poor cuts.	Blade is dull or dirty.	Clean, sharpen, or replace blade.
	Blade is wrong type for cut being made.	Replace with correct type.
	Blade is mounted backwards.	Remount blade.
Blade does not lower when turning height/bevel adjusting handwheel.	Locking lever is not at full left position.	Move locking lever to left.
Motor labors in rip cut.	Blade not proper for rip cut.	Change blade; rip blade typically has fewer teeth.

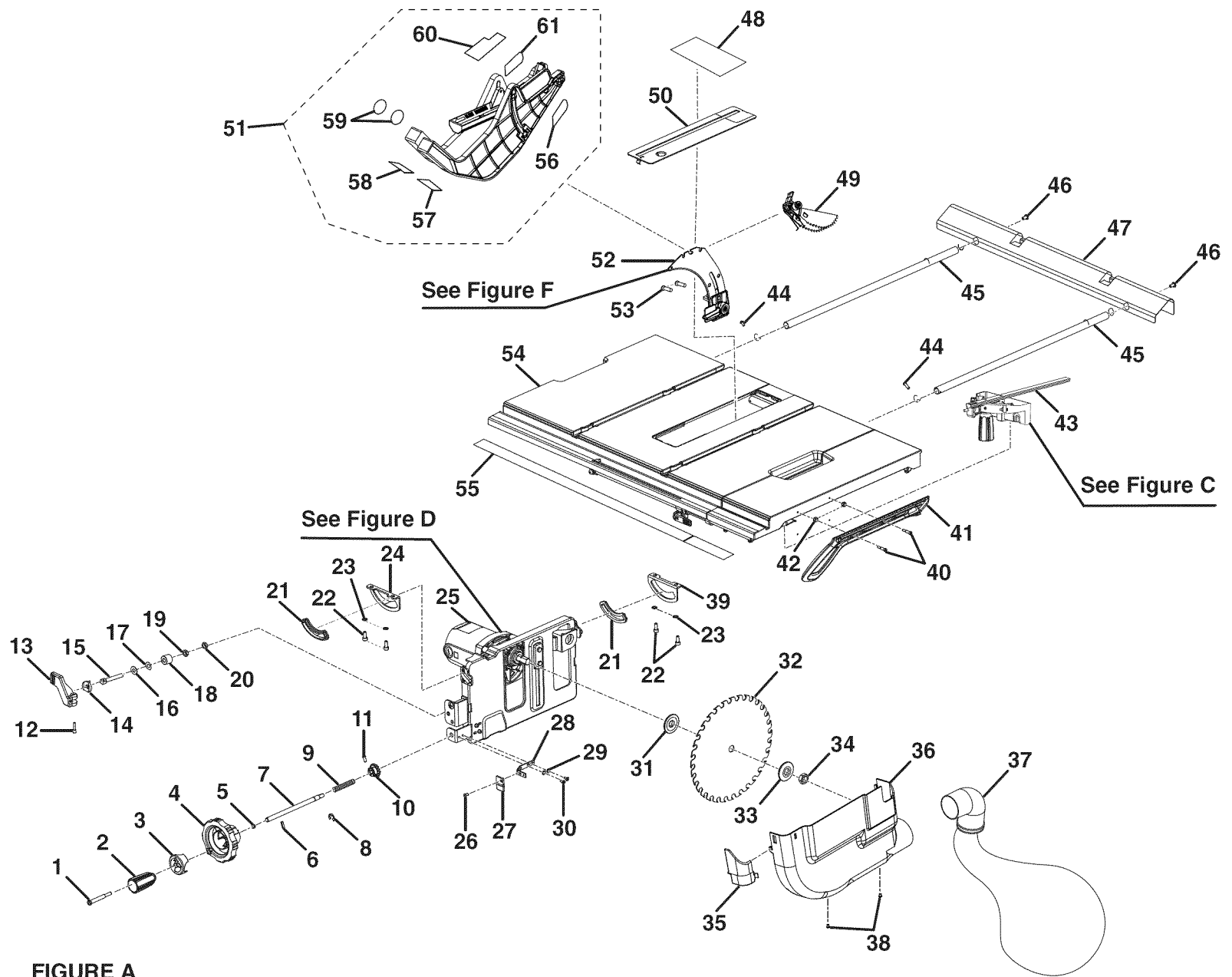

FIGURE A

CRAFTSMAN 10 in. TABLE SAW – MODEL NUMBER 315.284620

The model number will be found on a label attached to the cabinet. Always mention the model number in all correspondence regarding your **10 in. PORTABLE TABLE SAW** or when ordering parts.

PARTS LIST FOR FIGURE A

KEY NO.	PART NUMBER	DESCRIPTION	QTY	KEY NO.	PART NUMBER	DESCRIPTION	QTY
1	089037008032	Screw (M6 x 65 mm).....	1	34	089037008057	Nut (5/8 in. x 8 mm)	1
2	089037008031	Handle.....	1	35	089037008178	Dust Chute Cover	1
3	089110118004	End Cap	1	36	089037008058	Dust Chute.....	1
4	089110118003	Height/Bevel Adjusting Handwheel.....	1	37	089110118706	Dust Bag w/Elbow Assembly	1
5	089037008033	Nut (M6)	1	38	089037008059	Screw (10-32 x 8 mm)	2
6	089037008027	Pin (D3.6 x 22 mm)	1	39	089037008003	Bevel Trunnion - Rear	1
7	089037008025	Elevation Rod.....	1	40	089037008067	Screw (M3 x 10 mm).....	2
8	089037008026	E-Ring	1	41	089110118005	Push Stick.....	1
9	089037008028	Compression Spring (D11.8 x D9.8 x D1.0 x 65 mm).....	1	42	089037008068	Nut (M3)	2
10	089037008023	Bevel Gear	1	43	089110118704	Miter Gauge Assembly	1
11	089037008024	Screw (M4 x 20 mm).....	1	44	089037008065	Screw (M4 x 10 mm).....	2
12	089037008042	Screw (M4 x 18 mm).....	1	45	089037008063	Extension Rod (Ø16 x 1t x 535 mm).....	2
13	089037008041	Bevel Locking Lever	1	46	089037008064	Screw (M6 x 12 mm).....	2
14	089037008040	Pad.....	1	47	089037008062	Outfeed Support.....	1
15	089037008034	Screw (M8 x 51 mm).....	1	48	089037008908	Warning Label.....	1
16	089037008037	Washer (D18 x D8.5 x 2t).....	1	49	089037008705	Anti-Kickback Pawls.....	1
17	089037008036	Spring (D18 x 8.4 x 1t).....	1	50	089110118702	Throat Plate Assembly.....	1
18	089037008035	Bevel Bushing (D20 x D8.5 x 116.9t).....	1	51	089110118703	Blade Guard Assembly (Inc. Key Nos. 56-61)	1
19	089037008038	Nut (M8)	1	52	089037008703	Spreader/Riving Knife Assembly	1
20	089037008039	Nut (M8)	1	53	089037008060	Screw (M6 x 16 mm).....	2
21	089037008004	Slider - Undercarriage.....	2	54	089110118701	Saw Table Assembly.....	1
22	089037008005	Screw (M6 x 12 mm)	4	55	089110118903	Rip Scale.....	1
23	089037008006	Washer (M6).....	4	56	089037008905	Inner Guard Installation Label.....	1
24	089037008007	Bevel Trunnion - Front	1	57	089110118908	Side Barrier Warning - Right.....	1
25	089037008702	Motor Assembly.....	1	58	089110118909	Side Barrier Warning - Left	1
26	089037008046	Screw (M4 x 7 mm).....	1	59	089110113913	No Hands Warning Label.....	2
27	089037008045	Indicator.....	1	60	089110118905	Upper Barrier Warning Label	1
28	089037008043	Indicator Holder	1	61	089110118904	Outer Guard Installation Label.....	1
29	089037008018	Washer (M4).....	2			Not Shown:	
30	089037008044	Screw (M4 x 10 mm).....	2		089110118708	Optional Dado Throat Plate	1
31	089037008055	Inner Blade Washer.....	1		987000910	Operator's Manual	1
32	089110118001	Blade (10 in. x 5/8 in. x 36t).....	1				
33	089037008056	Outer Blade Washer.....	1				

CRAFTSMAN 10 in. TABLE SAW – MODEL NUMBER 315.284620

The model number will be found on a label attached to the cabinet. Always mention the model number in all correspondence regarding your **10 in. PORTABLE TABLE SAW** or when ordering parts.

PARTS LIST FOR FIGURE B

KEY NO.	PART NUMBER	DESCRIPTION	QTY
1	089110118707	Quick Stand (Leg Stand).....	1
2	089037008901	Warning Label.....	1
3	089110118901	Main Label.....	1
4	089037008010	Nut (M6).....	4
5	089110118015	Cabinet.....	1
6	089110118002	Locking Knob.....	4
7	089110118705	Rip Fence Assembly.....	1
8	089037008022	Screw (M4 x 15 mm).....	2
9	089037008021	Gear Rack.....	1
10	089037008020	Screw (10 x 8 mm).....	2
11	089037008015	Screw (M5 x 16 mm).....	2
12	089037008016	Washer (M5).....	2
13	089037008014	Reinforcement Plate.....	1
14	089037008019	Cam (4 mm).....	2
15	089037008018	Washer (M4).....	4

KEY NO.	PART NUMBER	DESCRIPTION	QTY
16	089037008017	Screw (M4 x 5 mm).....	2
17	089037008053	Screw (M4 x 18 mm).....	7
18	089110101701	Switch Assembly.....	1
19	089037008050	Switch Box.....	1
20	089037008054	Pad.....	1
21	089037008012	Knob Ring.....	1
22	089037008047	Blade Wrench.....	2
23	089037008048	Knob.....	1
24	089037008051	Strain Relief.....	1
25	089037008052	Power Cord.....	1
26	089037007902	Warning Label.....	1
27	089037008011	Bolt (M8 x 40 mm).....	1
28	089037008013	Screw (M6 x 25 mm).....	4
29	089110118902	Data Label.....	1
30	0121010232	Switch Key.....	1

CRAFTSMAN 10 in. TABLE SAW - MODEL NUMBER 315.284620

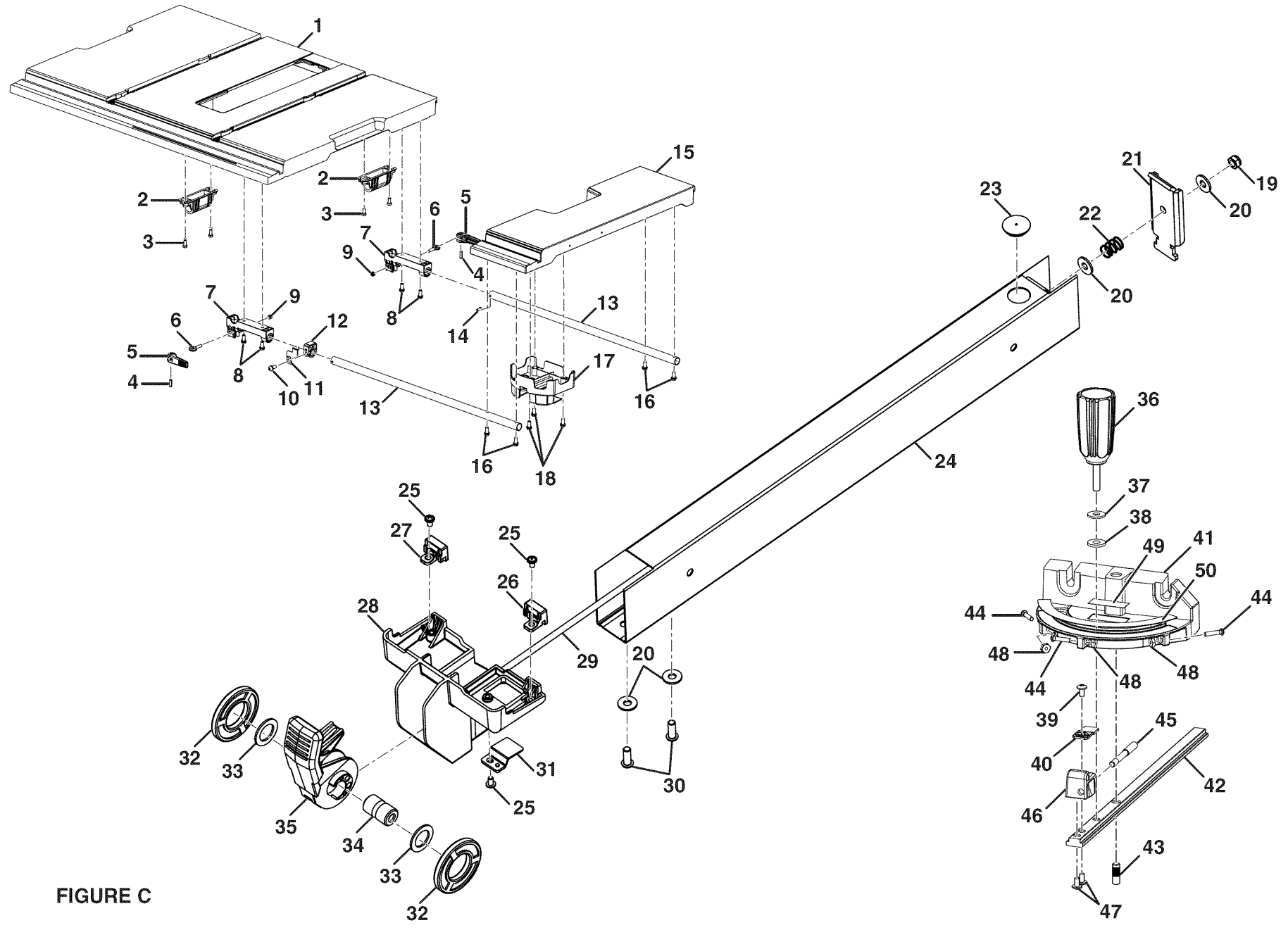

FIGURE C

CRAFTSMAN 10 in. TABLE SAW – MODEL NUMBER 315.284620

The model number will be found on a label attached to the cabinet. Always mention the model number in all correspondence regarding your **10 in. PORTABLE TABLE SAW** or when ordering parts.

PARTS LIST FOR FIGURE C

KEY NO.	PART NUMBER	DESCRIPTION	QTY	KEY NO.	PART NUMBER	DESCRIPTION	QTY
1	089110118006	Saw Table	1	26	089037008156	Rip Fence Slider - Left.....	1
2	089037008073	Outfeed Bracket.....	2	27	089037008155	Rip Fence Slider - Right.....	1
3	089037008179	Screw (M5 x 12 mm).....	4	28	089110118010	Rip Fence Block.....	1
4	089037008078	Pin (D5 x 16 mm).....	2	29	089037008162	Rod (D5.2 x 580 mm).....	1
5	089037008076	Table Locking Lever.....	2	30	089037008164	Screw (M6 x 16 mm).....	2
6	089037008077	Bolt	2	31	089037008168	Indicator.....	1
7	089037008075	Extension Rod Bracket.....	2	32	089037008161	Ring Pad	2
8	089037008074	Screw (M5 x 12 mm).....	4	33	089037008160	Washer (D25 x D16 x 1.5t)	2
9	089037008079	Nut (M5).....	2	34	089037008159	Bushing.....	1
10	089037008085	Screw (M4 x 25 mm).....	1	35	089037008158	Locking Lever	1
11	089037008084	Indicator.....	1	36	089037008076	Miter Lock Knob	1
12	089037008083	End Plug	1	37	089037008153	Washer (D16 in. x D1/4 x 1.5t)	1
13	089110118007	Extention Rod (D16 x 1.2t x 641.2 mm).....	2	38	089037008149	Washer (D16 x D6.5 x 1.8t)	1
14	089037008065	Screw (M4 x 10 mm).....	1	39	089037009043	Screw (M4 x 10 mm).....	1
15	089110118008	Sliding Table Extension.....	1	40	089037009042	Indicator.....	1
16	089037008081	Screw (M5 x 25 mm).....	4	41	089110118009	Miter Gauge	1
17	089037008086	Miter Gauge Storage Holder.....	1	42	089037009039	Miter Gauge Rod	1
18	089037008087	Screw (M4 x 12 mm).....	3	43	089037009038	Roll Pin (D1/4 x 18 mm).....	1
19	089037008033	Nut (M6).....	1	44	089037009036	Screw (6-32 x 5/8 in.).....	3
20	089037008165	Washer (D1/4 in. x D16 x 1.5t).....	4	45	089037009041	Pin (D6.15 x 23 mm)	1
21	089037008166	Rear Clamp.....	1	46	089037009040	Indicator Holder	1
22	089037008167	Spring (D10.4 x D8 x D1.2 x 32L)	1	47	089037008065	Screw (M4 x 10 mm).....	2
23	089037008169	End Cap.....	1	48	089037009037	Hex Nut (6-32).....	3
24	089037008163	Rip Fence.....	1	49	089110118907	Logo Label.....	1
25	089037008157	Screw (M4 x 8 mm).....	3	50	089110118906	Scale (Miter Gauge)	1

CRAFTSMAN 10 in. TABLE SAW - MODEL NUMBER 315.284620

See Note On Page 48

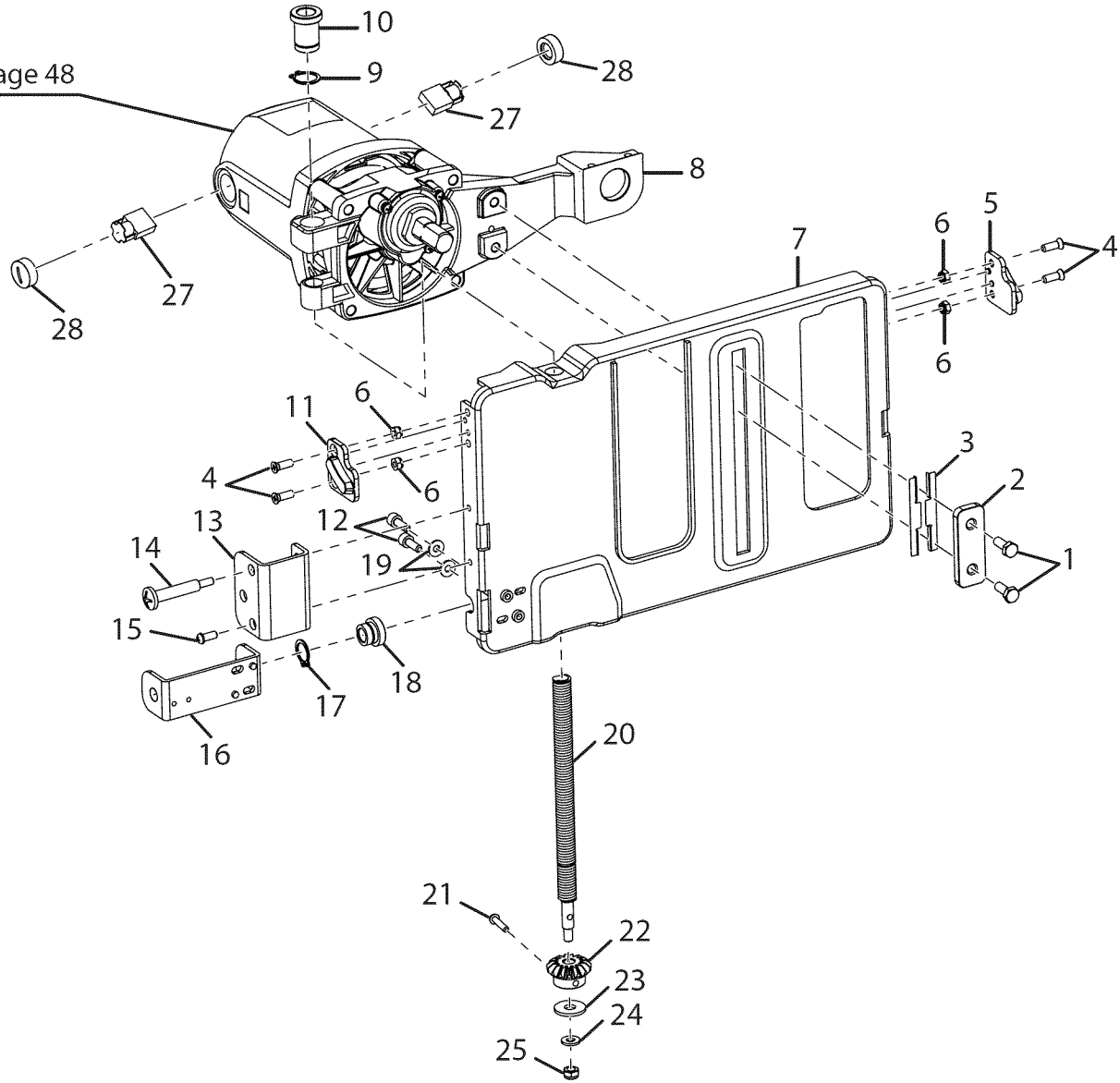

FIGURE D

CRAFTSMAN 10 in. TABLE SAW – MODEL NUMBER 315.284620

The model number will be found on a label attached to the cabinet. Always mention the model number in all correspondence regarding your **10 in. PORTABLE TABLE SAW** or when ordering parts.

PARTS LIST FOR FIGURE D

KEY NO.	PART NUMBER	DESCRIPTION	QTY	KEY NO.	PART NUMBER	DESCRIPTION	QTY
1	089037008096	Screw (M6 x 16 mm).....	2	18	089037008106	Bushing.....	1
2	089037008094	T-Nut (Undercarriage).....	1	19	089037008105	Washer (D5 x D12 x 1.5t).....	2
3	089037008095	T-Nut (Wear Plate).....	2	20	089037008091	Elevation Rod.....	1
4	089037008099	Screw (M5 x 14 mm).....	4	21	089037008024	Screw (M4 x 20 mm).....	1
5	089037008097	Pivot Plate-Rear.....	1	22	089037008023	Bevel Gear.....	1
6	089037008079	Nut (M5).....	4	23	089037008092	Washer (D8 x D22 x 2t).....	1
7	089037008088	Undercarriage.....	1	24	089037008093	Washer (D6.2 x D12 x 2t).....	1
8	089037008708	Motor Assembly.....	1	25	089037008033	Nut (M6).....	1
9	089037008090	Ring (S17).....	1	26	089037008173	Key (4 x 4 x 10).....	1
10	089037008089	Bushing.....	1	27	089037008115	Brush.....	2
11	089037008098	Pivot Plate-Front.....	1	28	089037008116	Brush Cap.....	2
12	089037008104	Screw (M5 x 12 mm).....	2	29	089037008170	Arbor.....	1
13	089037008100	Bracket - Undercarriage.....	1	30	089037008172	Ball Bearing (6002 LLU CM).....	1
14	089037008101	Screw (M5 x 12 mm).....	1	31	089037008107	C-Ring (S-15).....	1
15	089037008102	Screw (M5 x 12 mm).....	1	32	089037008171	Bearing Cover Plate.....	1
16	089037008103	Bracket.....	1	33	089037008174	Reduction Gear.....	1
17	089037008107	C-Ring.....	1				

NOTE: The assembly shown represents an important part of the double insulated system. To avoid the possibility of alteration or damage to the system, service should be performed by your nearest Sears Repair Center. Contact your nearest Sears retail store for service center information.

CRAFTSMAN 10 in. TABLE SAW – MODEL NUMBER 315.284620

The model number will be found on a label attached to the cabinet. Always mention the model number in all correspondence regarding your **TABLE SAW** or when ordering repair parts.

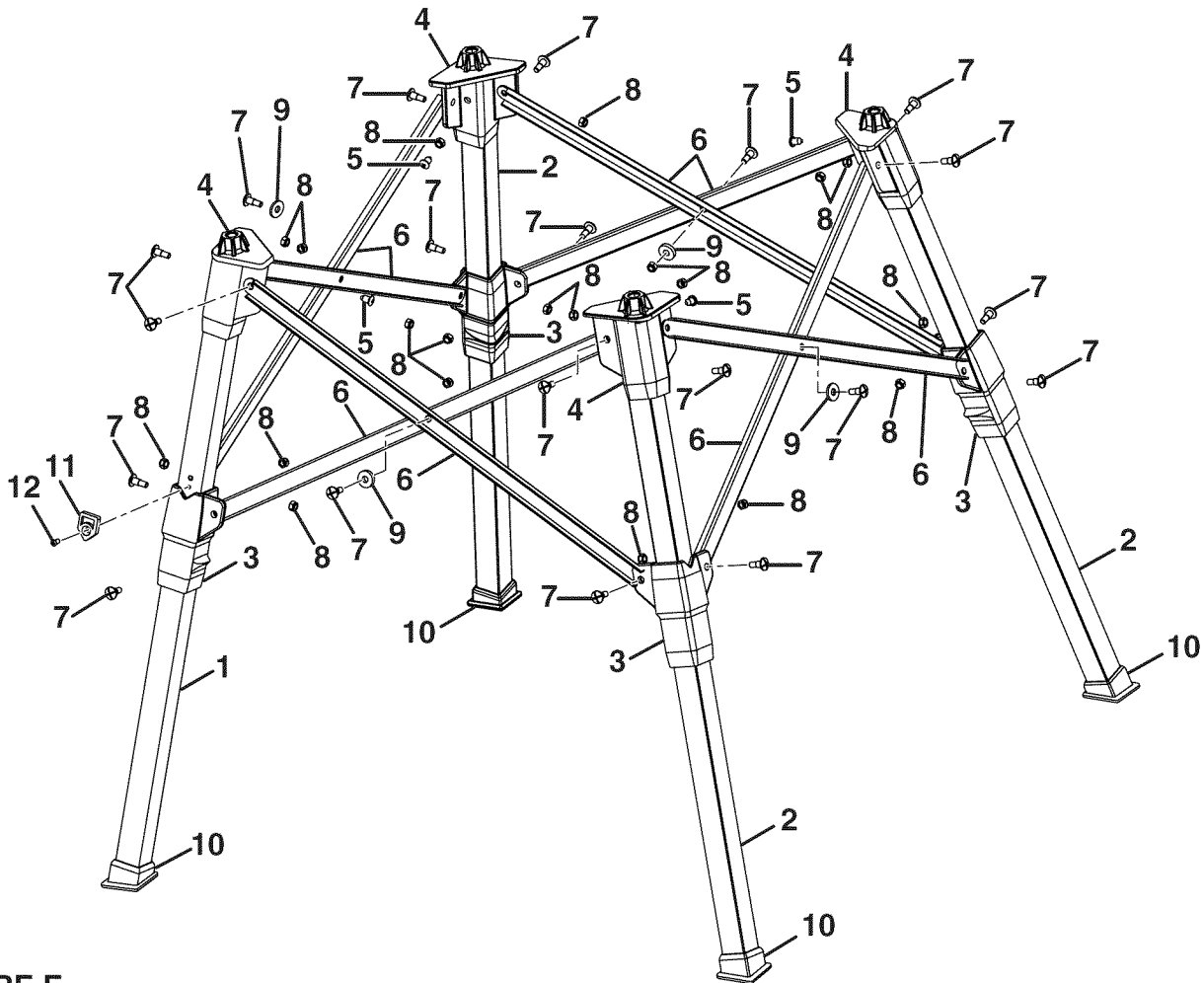

FIGURE E

PARTS LIST FOR FIGURE E

KEY NO.	PART NUMBER	DESCRIPTION	QTY.
1	089110118011	Leg "A"	1
2	089110118012	Leg "B"	3
3	089037008183	Leg Adaptor	4
4	089037008184	Connector Bracket.....	4
5	089037008185	Screw (M5 x 10 mm)	4
6	089110118013	Linkage.....	8
7	089037008187	Screw (M5 x 15 mm)	20
8	089037008188	Lock Nut (M5).....	20
9	089037008189	Spacer.....	4
10	089037008190	Foot.....	4
11	089037008191	Red Indicator.....	1
12	089037008192	Screw (M4 x 8 mm)	1

CRAFTSMAN 10 in. TABLE SAW – MODEL NUMBER 315.284620

The model number will be found on a label attached to the cabinet. Always mention the model number in all correspondence regarding your **TABLE SAW** or when ordering repair parts.

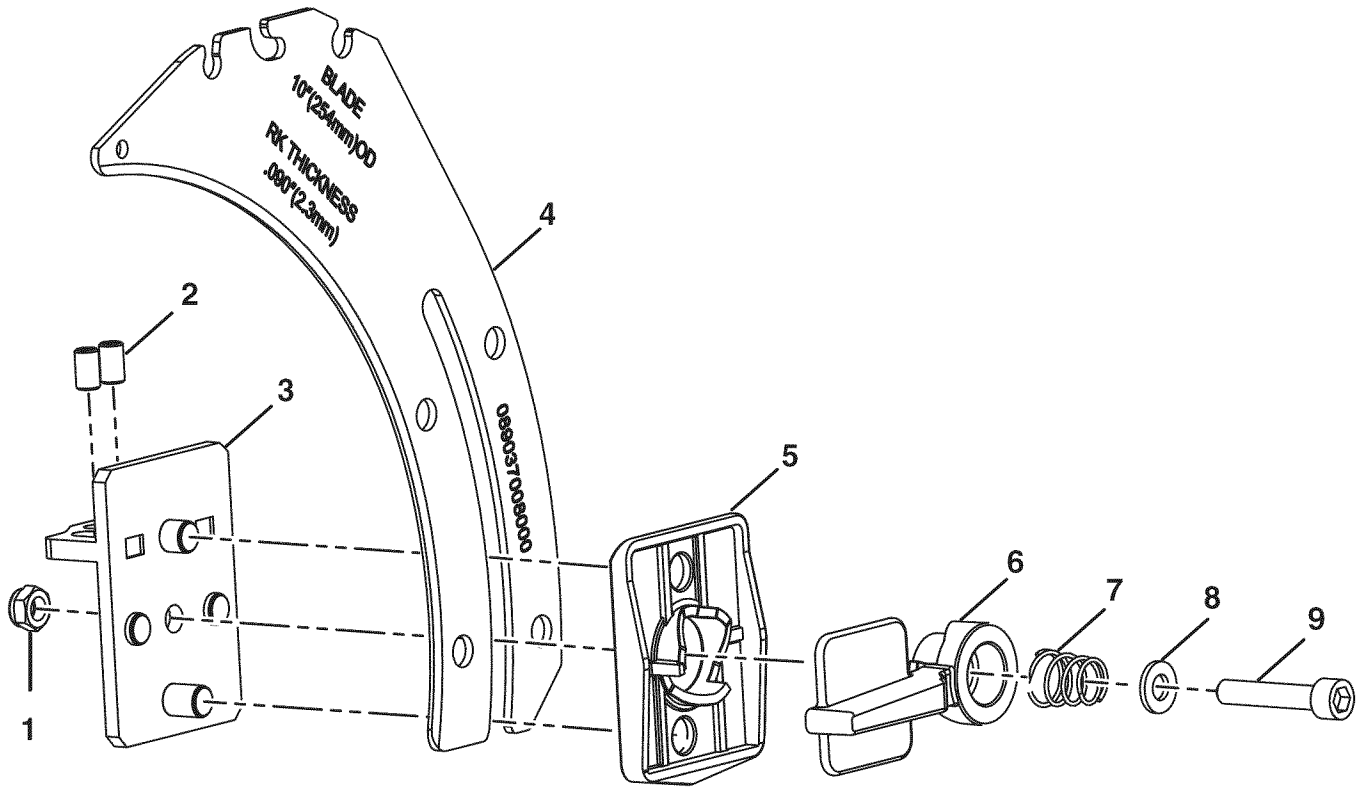

FIGURE F

PARTS LIST FOR FIGURE F

KEY NO.	PART NUMBER	DESCRIPTION	QTY.
1	089037008033	Nut (M6)	1
2	089037008124	Screw (M6 x 10 mm).....	2
3	089037008119	Deck	1
4	089037008000	Spreader/Riving Knife.....	1
5	089037008120	Clamp	1
6	089037008121	Release Lever	1
7	089037008123	Spring (D10 x D6.5 x 16L).....	1
8	089037008125	Washer (D14 x D6.5 x 2t).....	1
9	089037008122	Screw (M6 x 32 mm).....	1

Get it fixed, at your home or ours!

Your Home

For expert troubleshooting and home solutions advice:

manage my home

www.managemyhome.com

For repair – **in your home** – of **all** major brand appliances, lawn and garden equipment, or heating and cooling systems, **no matter who made it, no matter who sold it!**

For the replacement parts, accessories and owner's manuals that you need to do-it-yourself.

For Sears professional installation of home appliances and items like garage door openers and water heaters.

1-800-4-MY-HOME[®] (1-800-469-4663)

Call anytime, day or night (U.S.A. and Canada)

www.sears.com www.sears.ca

Our Home

For repair of carry-in items like vacuums, lawn equipment, and electronics, call anytime for the location of your nearest

Sears Parts & Repair Service Center

1-800-488-1222 (U.S.A.)

www.sears.com

1-800-469-4663 (Canada)

www.sears.ca

To purchase a protection agreement on a product serviced by Sears:

1-800-827-6655 (U.S.A.)

1-800-361-6665 (Canada)

Para pedir servicio de reparación a domicilio, y para ordenar piezas:

1-888-SU-HOGAR[®]

(1-888-784-6427)

Au Canada pour service en français:

1-800-LE-FOYER^{MC}

(1-800-533-6937)

www.sears.ca

Sears

® Registered Trademark / TM Trademark / SM Service Mark of Sears Brands, LLC

© Marca Registrada / TM Marca de Fábrica / SM Marca de Servicio de Sears Brands, LLC

MC Marque de commerce / MD Marque déposée de Sears Brands, LLC

© Sears Brands, LLC