

 **Husqvarna**[®]



917.289610
(YTH2042)

Owner's Manual



SAFETY RULES



Safe Operation Practices for Ride-On Mowers

DANGER: THIS CUTTING MACHINE IS CAPABLE OF AMPUTATING HANDS AND FEET AND THROWING OBJECTS. FAILURE TO OBSERVE THE FOLLOWING SAFETY INSTRUCTIONS COULD RESULT IN SERIOUS INJURY OR DEATH.



WARNING: In order to prevent accidental starting when setting up, transporting, adjusting or making repairs, always disconnect spark plug wire and place wire where it cannot contact spark plug.



WARNING: Do not coast down a hill in neutral, you may lose control of the tractor.



WARNING: Tow only the attachments that are recommended by and comply with specifications of the manufacturer of your tractor. Use common sense when towing. Operate only at the lowest possible speed when on a slope. Too heavy of a load, while on a slope, is dangerous. Tires can lose traction with the ground and cause you to lose control of your tractor.



WARNING



Engine exhaust, some of its constituents, and certain vehicle components contain or emit chemicals known to the State of California to cause cancer and birth defects or other reproductive harm.



WARNING



Battery posts, terminals and related accessories contain lead and lead compounds, chemicals known to the State of California to cause cancer and birth defects or other reproductive harm. Wash hands after handling.

I. GENERAL OPERATION

- Read, understand, and follow all instructions on the machine and in the manual before starting.
- Do not put hands or feet near rotating parts or under the machine. Keep clear of the discharge opening at all times.
- Only allow responsible adults, who are familiar with the instructions, to operate the machine.
- Clear the area of objects such as rocks, toys, wire, etc., which could be picked up and thrown by the blades.
- Be sure the area is clear of bystanders before operating. Stop machine if anyone enters the area.
- Never carry passengers.
- Do not mow in reverse unless absolutely necessary. Always look down and behind before and while backing.
- Never direct discharged material toward anyone. Avoid discharging material against a wall or obstruction. Material may ricochet back toward the operator. Stop the blades when crossing gravel surfaces.

- Do not operate machine without the entire grass catcher, discharge chute, or other safety devices in place and working.
- Slow down before turning.
- Never leave a running machine unattended. Always turn off blades, set parking brake, stop engine, and remove keys before dismounting.
- Disengage blades when not mowing. Shut off engine and wait for all parts to come to a complete stop before cleaning the machine, removing the grass catcher, or unclogging the discharge chute.
- Operate machine only in daylight or good artificial light.
- Do not operate the machine while under the influence of alcohol or drugs.
- Watch for traffic when operating near or crossing roadways.
- Use extra care when loading or unloading the machine into a trailer or truck.
- Always wear eye protection when operating machine.
- Data indicates that operators, age 60 years and above, are involved in a large percentage of riding mower-related injuries. These operators should evaluate their ability to operate the riding mower safely enough to protect themselves and others from serious injury.
- Follow the manufacturer's recommendation for wheel weights or counterweights.
- Keep machine free of grass, leaves or other debris build-up which can touch hot exhaust / engine parts and burn. Do not allow the mower deck to plow leaves or other debris which can cause build-up to occur. Clean any oil or fuel spillage before operating or storing the machine. Allow machine to cool before storage.

II. SLOPE OPERATION

Slopes are a major factor related to loss of control and tip-over accidents, which can result in severe injury or death. Operation on all slopes requires extra caution. If you cannot back up the slope or if you feel uneasy on it, do not mow it.

- Mow up and down slopes, not across.
- Watch for holes, ruts, bumps, rocks, or other hidden objects. Uneven terrain could overturn the machine. Tall grass can hide obstacles.
- Choose a low ground speed so that you will not have to stop or shift while on the slope.
- Do not mow on wet grass. Tires may lose traction. Always keep the machine in gear when going down slopes. Do not shift to neutral and coast downhill.
- Avoid starting, stopping, or turning on a slope. If the tires lose traction, disengage the blades and proceed slowly straight down the slope.
- Keep all movement on the slopes slow and gradual. Do not make sudden changes in speed or direction, which could cause the machine to roll over.
- Use extra care while operating machine with grass catchers or other attachments; they can affect the stability of the machine. Do no use on steep slopes.
- Do not try to stabilize the machine by putting your foot on the ground.
- Do not mow near drop-offs, ditches, or embankments. The machine could suddenly roll over if a wheel is over the edge or if the edge caves in.



SAFETY RULES



Safe Operation Practices for Ride-On Mowers

III. CHILDREN

Tragic accidents can occur if the operator is not alert to the presence of children. Children are often attracted to the machine and the mowing activity. *Never* assume that children will remain where you last saw them.

- Keep children out of the mowing area and in the watchful care of a responsible adult other than the operator.
- Be alert and turn machine off if a child enters the area.
- Before and while backing, look behind and down for small children.
- Never carry children, even with the blades shut off. They may fall off and be seriously injured or interfere with safe machine operation. Children who have been given rides in the past may suddenly appear in the mowing area for another ride and be run over or backed over by the machine.
- Never allow children to operate the machine.
- Use extra care when approaching blind corners, shrubs, trees, or other objects that may block your view of a child.

IV. TOWING

- Tow only with a machine that has a hitch designed for towing. Do not attach towed equipment except at the hitch point.
- Follow the manufacturer's recommendation for weight limits for towed equipment and towing on slopes.
- Never allow children or others in or on towed equipment.
- On slopes, the weight of the towed equipment may cause loss of traction and loss of control.
- Travel slowly and allow extra distance to stop.

V. SAFE HANDLING OF GASOLINE

To avoid personal injury or property damage, use extreme care in handling gasoline. Gasoline is extremely flammable and the vapors are explosive.

- Extinguish all cigarettes, cigars, pipes, and other sources of ignition.
- Use only approved gasoline container.
- Never remove gas cap or add fuel with the engine running. Allow engine to cool before refueling.
- Never fuel the machine indoors.
- Never store the machine or fuel container where there is an open flame, spark, or pilot light such as on a water heater or other appliances.
- Never fill containers inside a vehicle or on a truck or trailer bed with plastic liner. Always place containers on the ground away from your vehicle when filling.
- Remove gas-powered equipment from the truck or trailer and refuel it on the ground. If this is not possible, then refuel such equipment with a portable container, rather than from a gasoline dispenser nozzle.
- Keep the nozzle in contact with the rim of the fuel tank or container opening at all times until fueling is complete. Do not use a nozzle lock-open device.
- If fuel is spilled on clothing, change clothing immediately.
- Never overfill fuel tank. Replace gas cap and tighten securely.

GENERAL

- Never operate machine in a closed area.
- Keep all nuts and bolts tight to be sure the equipment is in safe working condition.
- Never tamper with safety devices. Check their proper operation regularly.
- Keep machine free of grass, leaves, or other debris build-up. Clean oil or fuel spillage and remove any fuel-soaked debris. Allow machine to cool before storing.
- If you strike a foreign object, stop and inspect the machine. Repair, if necessary, before restarting.
- Never make any adjustments or repairs with the engine running.
- Check grass catcher components and the discharge chute frequently and replace with manufacturer's recommended parts, when necessary.
- Mower blades are sharp. Wrap the blade or wear gloves, and use extra caution when servicing them.
- Check brake operation frequently. Adjust and service as required.
- Maintain or replace safety and instruction labels, as necessary.



- Be sure the area is clear of bystanders before operating. Stop machine if anyone enters the area.
- Never carry passengers.
- Do not mow in reverse unless absolutely necessary. Always look down and behind before and while backing.
- Never carry children, even with the blades shut off. They may fall off and be seriously injured or interfere with safe machine operation. Children who have been given rides in the past may suddenly appear in the mowing area for another ride and be run over or backed over by the machine.
- Keep children out of the mowing area and in the watchful care of a responsible adult other than the operator.
- Be alert and turn machine off if a child enters the area.
- Before and while backing, look behind and down for small children.
- Mow up and down slopes (15° Max), not across.
- Choose a low ground speed so that you will not have to stop or shift while on the slope.
- Avoid starting, stopping, or turning on a slope. If the tires lose traction, disengage the blades and proceed slowly straight down the slope.
- If machine stops while going uphill, disengage blades, shift into reverse and back down slowly.
- Do not turn on slopes unless necessary, and then, turn slowly and gradually downhill, if possible.

PRODUCT SPECIFICATIONS

| | |
|-----------------------------|---|
| Gasoline Capacity and Type: | 2.5 Gallons Unleaded Regular |
| Oil Type (API-SG-SL): | SAE 30 (above 32°F) SAE 5W-30 (below 32°F) |
| Oil Capacity: | W/Filter: 56 oz. W/O Filter: 48 oz. |
| Spark Plug: | Champion RC12YC (Gap: .030") |
| Ground Speed (MPH): | Forward: 0 - 5.2 Reverse: 0 - 2.9 |
| Charging System: | 3 AMPS Battery 5 AMPS Headlight |
| Battery: | AMP/HR: 28 Min. CCA: 230 Case Size: U1R |
| Blade Bolt Torque: | 45-55 Ft. Lbs. |

CONGRATULATIONS on your purchase of a new tractor. It has been designed, engineered and manufactured to give you the best possible dependability and performance.

Should you experience any problem you cannot easily remedy, please contact your nearest authorized service center/department. We have competent, well-trained technicians and the proper tools to service or repair this tractor.

Please read and retain this manual. The instructions will enable you to assemble and maintain your tractor properly. Always observe the "SAFETY RULES".

CUSTOMER RESPONSIBILITIES

- Read and observe the safety rules.
- Follow a regular schedule in maintaining, caring for and using your tractor.
- Follow the instructions under "Maintenance" and "Storage" sections of this owner's manual.

WARNING: This tractor is equipped with an internal combustion engine and should not be used on or near any unimproved forest-covered, brush-covered or grass-covered land unless the engine's exhaust system is equipped with a spark arrester meeting applicable local or state laws (if any). If a spark arrester is used, it should be maintained in effective working order by the operator.

In the state of California the above is required by law (Section 4442 of the California Public Resources Code). Other states may have similar laws. Federal laws apply on federal lands.

TABLE OF CONTENTS

| | |
|--------------------------------|------|
| SAFETY RULES | 2-3 |
| PRODUCT SPECIFICATIONS..... | 4 |
| CUSTOMER RESPONSIBILITIES..... | 4 |
| ASSEMBLY | 5-6 |
| OPERATION | 7-12 |
| MAINTENANCE SCHEDULE | 13 |

| | |
|------------------------------|-------|
| MAINTENANCE | 13-16 |
| SERVICE AND ADJUSTMENTS..... | 17-22 |
| STORAGE..... | 26 |
| TROUBLESHOOTING..... | 24-25 |
| REPAIR PARTS | 26-48 |

UNASSEMBLED PARTS

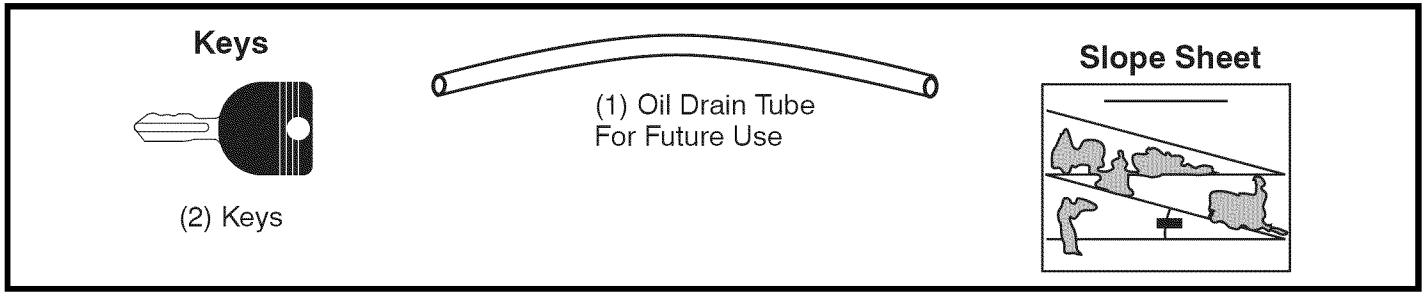

ASSEMBLY

Your new tractor has been assembled at the factory with exception of those parts left unassembled for shipping purposes.

TOOLS REQUIRED FOR ASSEMBLY

A socket wrench set will make assembly easier. Standard wrench sizes are listed.

- | | |
|--------------------|---------------------|
| (1) 1/2" wrench | Tire pressure gauge |
| (2) 7/16" wrenches | Utility knife |
| | Pliers |

When right or left hand is mentioned in this manual, it means when you are in the operating position (seated behind the steering wheel).

TO REMOVE TRACTOR FROM CARTON

UNPACK CARTON

- Remove all accessible loose parts and parts cartons from carton .
- Cut along dotted lines on all four panels of carton. Remove end panels and lay side panels flat.
- Check for any additional loose parts or cartons and remove.

BEFORE REMOVING TRACTOR FROM SKID

TO CHECK BATTERY (See Fig. 1)

- Lift seat to raised position.

NOTE: If this battery is put into service after month and year indicated on label (label is located between terminals) charge battery for minimum of one hour at 6-10 amps. (See "BATTERY" in Maintenance section of this manual for charging instructions).

- For battery and battery cable installation see "REPLACING BATTERY" in the "Service and Adjustments" section in this manual.

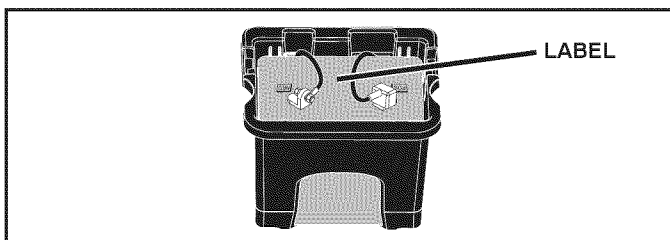

Fig. 1

ADJUST SEAT (See Fig. 2)

- Sit in seat.
- Lift up adjustment lever (A) and slide seat until a comfortable position is reached which allows you to press clutch/brake pedal all the way down.
- Release lever to lock seat in position.

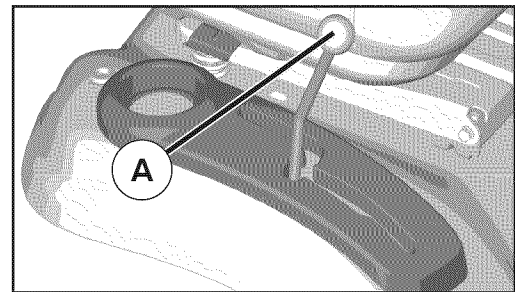

Fig. 2

NOTE: You may now roll your tractor off the skid. Follow the instructions below to remove the tractor from the skid.

WARNING: Before starting, read, understand and follow all instructions in the Operation section of this manual. Be sure tractor is in a well-ventilated area. Be sure the area in front of tractor is clear of other people and objects.

TO ROLL TRACTOR OFF SKID (See Operation section for location and function of controls)

- Raise attachment lift lever to its highest position.
- Release parking brake by depressing clutch/brake pedal.
- Place freewheel control in "transmission disengaged" position (See "TO TRANSPORT" in the Operation section of this manual).
- Roll tractor forward off skid.
- Remove banding holding the deflector shield up against tractor.

Continue with the instructions that follow.

ASSEMBLY

CHECK TIRE PRESSURE

The tires on your tractor were overinflated at the factory for shipping purposes. Correct tire pressure is important for best cutting performance.

- Reduce tire pressure to PSI shown on tires.

CHECK DECK LEVELNESS

For best cutting results, mower housing should be properly leveled. See "TO LEVEL MOWER" in the Service and Adjustments section of this manual.

CHECK FOR PROPER POSITION OF ALL BELTS

See the figures that are shown for replacing motion and mower blade drive belts in the Service and Adjustments section of this manual. Verify that the belts are routed correctly.

CHECK BRAKE SYSTEM

After you learn how to operate your tractor, check to see that the brake is operating properly. See "TO CHECK BRAKE" in the Service and Adjustments section of this manual.

✓ CHECKLIST

BEFORE YOU OPERATE YOUR NEW TRACTOR, WE WISH TO ASSURE THAT YOU RECEIVE THE BEST PERFORMANCE AND SATISFACTION FROM THIS QUALITY PRODUCT.

PLEASE REVIEW THE FOLLOWING CHECKLIST:

- ✓ All assembly instructions have been completed.
- ✓ No remaining loose parts in carton.
- ✓ Battery is properly prepared and charged.
- ✓ Seat is adjusted comfortably and tightened securely.
- ✓ All tires are properly inflated. (For shipping purposes, the tires were overinflated at the factory).
- ✓ Be sure mower deck is properly leveled side-to-side/front-to-rear for best cutting results. (Tires must be properly inflated for leveling).
- ✓ Check mower and drive belts. Be sure they are routed properly around pulleys and inside all belt keepers.
- ✓ Check wiring. See that all connections are still secure and wires are properly clamped.
- ✓ Before driving tractor, be sure freewheel control is in "transmission engaged" position (See "TO TRANSPORT" in the Operation section of this manual).

WHILE LEARNING HOW TO USE YOUR TRACTOR, PAY EXTRA ATTENTION TO THE FOLLOWING IMPORTANT ITEMS:

- ✓ Engine oil is at proper level.
- ✓ Fuel tank is filled with fresh, clean, regular unleaded gasoline.
- ✓ Become familiar with all controls, their location and function. Operate them before you start the engine.
- ✓ Be sure brake system is in safe operating condition.
- ✓ Be sure Operator Presence System and Reverse Operation System (ROS) are working properly (See the Operation and Maintenance sections in this manual).
- ✓ It is important to purge the transmission before operating your tractor for the first time. Follow proper starting and transmission purging instructions (See "TO START ENGINE" and "PURGE TRANSMISSION" in the Operation section of this manual).

OPERATION

These symbols may appear on your tractor or in literature supplied with the product. Learn and understand their meaning.

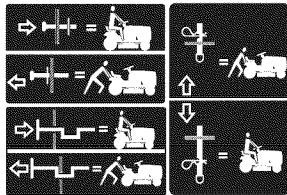
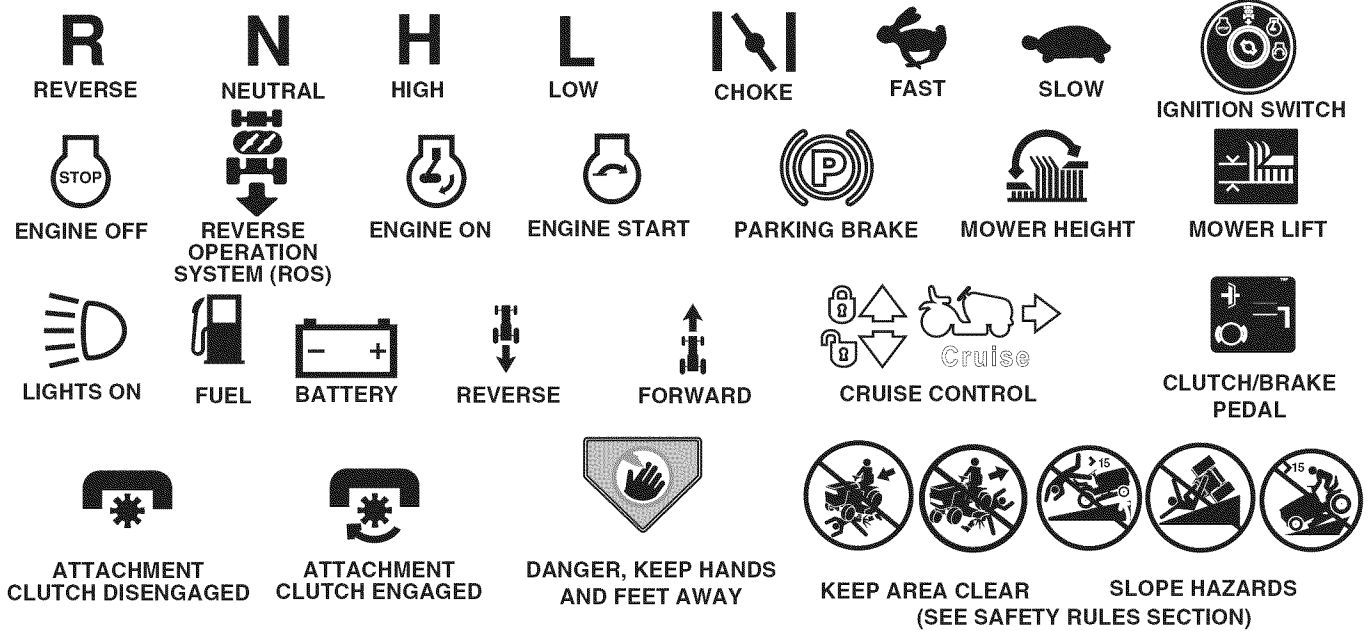

FREE WHEEL
(Automatic Models only)



Failure to follow instructions could result in serious injury or death. The safety alert symbol is used to identify safety information about hazards which can result in death, serious injury and/or property damage.



DANGER indicates a hazard which, if not avoided, will result in death or serious injury.



WARNING indicates a hazard which, if not avoided, could result in death or serious injury.



CAUTION indicates a hazard which, if not avoided, might result in minor or moderate injury.

CAUTION when used **without** the alert symbol, indicates a situation that **could result in damage to the tractor and/or engine.**



HOT SURFACES indicates a hazard which, if not avoided, could result in death, serious injury and/or property damage.



FIRE indicates a hazard which, if not avoided, could result in death, serious injury and/or property damage.

OPERATION

KNOW YOUR TRACTOR

READ THIS OWNER'S MANUAL AND SAFETY RULES BEFORE OPERATING YOUR TRACTOR

Compare the illustrations with your tractor to familiarize yourself with the locations of various controls and adjustments. Save this manual for future reference.

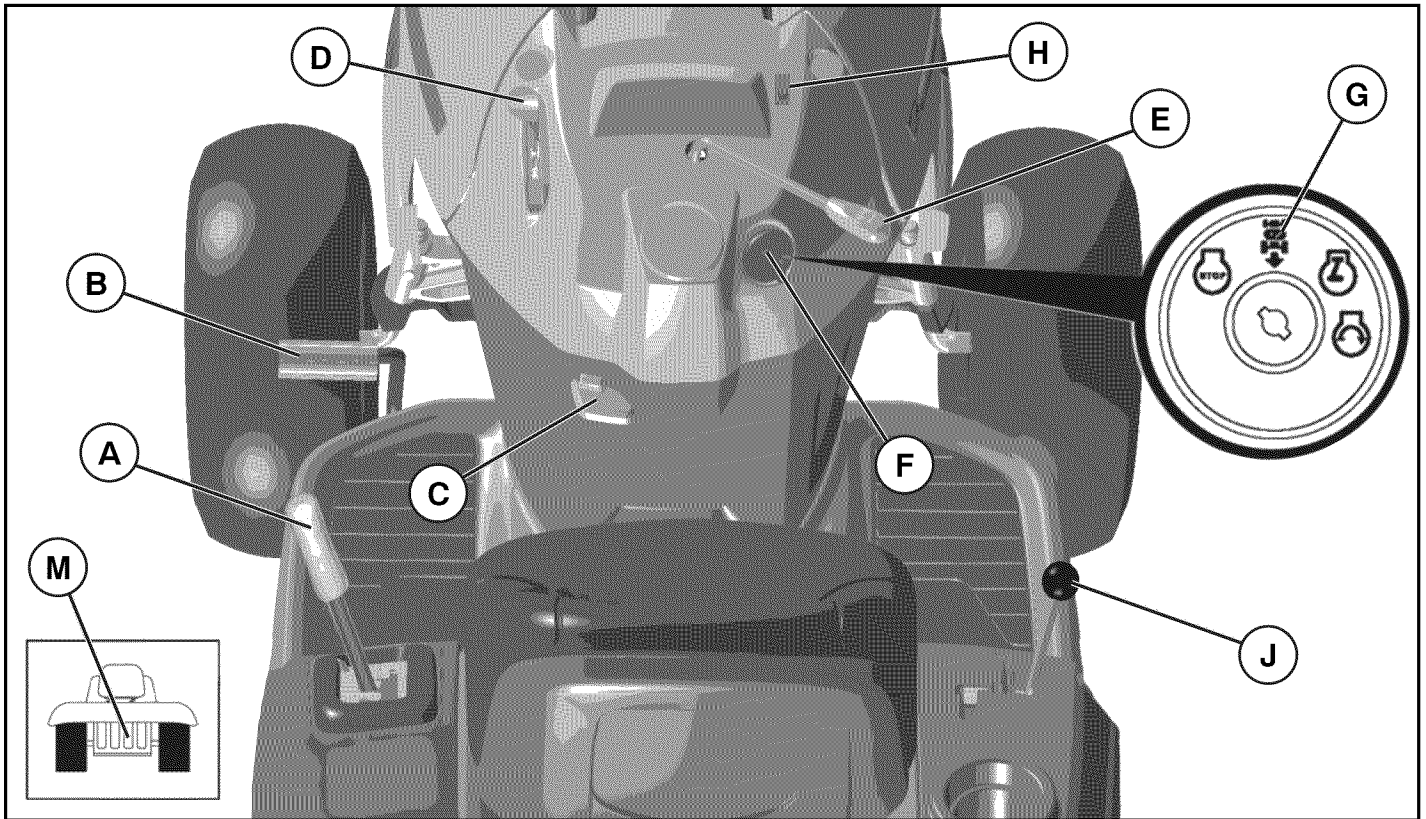

Fig. 3

Our tractors conform to the applicable safety standards of the American National Standards Institute.

(A) ATTACHMENT LIFT LEVER - Used to raise, lower, and adjust the mower deck or other attachments mounted to your tractor.

(B) CLUTCH/BRAKE PEDAL - Used for declutching and braking the tractor and starting the engine.

(C) PARKING BRAKE - Locks clutch/brake pedal into the brake position.

(D) THROTTLE/CHOKE CONTROL - Used for starting and controlling engine speed.

(E) ATTACHMENT CLUTCH LEVER - Used to engage the mower blades, or other attachments mounted to your tractor.

(F) IGNITION SWITCH - Used for starting and stopping the engine.

(G) REVERSE OPERATION SYSTEM (ROS) "ON" POSITION - Allows operation of mower deck or other powered attachment while in reverse.

(H) LIGHT SWITCH - Turns the headlights on and off.

(J) MOTION CONTROL LEVER - Selects the speed and direction of the tractor.

(M) FREEWHEEL CONTROL - Disengages transmission for pushing or slowly towing the tractor with the engine off.

OPERATION



The operation of any tractor can result in foreign objects thrown into the eyes, which can result in severe eye damage. Always wear safety glasses or eye shields while operating your tractor or performing any adjustments or repairs. We recommend a wide vision safety mask over spectacles or standard safety glasses.

HOW TO USE YOUR TRACTOR

TO SET PARKING BRAKE (See Fig. 4)

Your tractor is equipped with an operator presence sensing switch. When engine is running, any attempt by the operator to leave the seat without first setting the parking brake will shut off the engine.

- Depress clutch/brake pedal (B) all the way down and hold.
- Pull parking brake lever (C) up and hold, release pressure from clutch/brake pedal (B), then release parking brake lever. Pedal should remain in brake position. Make sure parking brake will hold tractor secure.

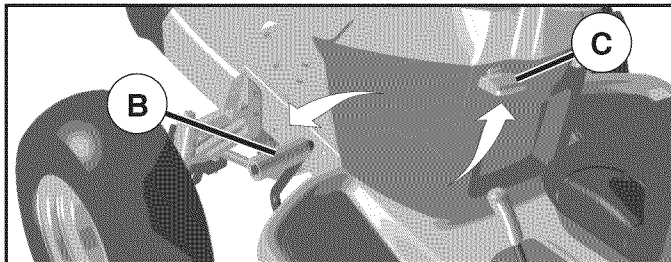
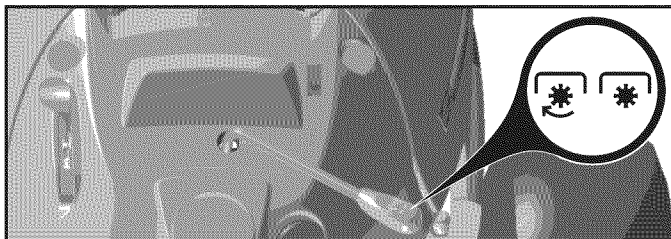

Fig. 4

STOPPING (See Fig. 5)

MOWER BLADES -

- To stop mower blades, place attachment clutch control in the "DISENGAGED" position (☒).



(☒) ATTACHMENT CLUTCH LEVER "DISENGAGED"

(☑) ATTACHMENT CLUTCH LEVER "ENGAGED"

Fig. 5

GROUND DRIVE -

- To stop ground drive, depress brake pedal all the way down.
- Move motion control lever (J) to neutral position.

ENGINE -

- Move throttle control (D) between half and full speed (fast) position.

NOTE: Failure to move throttle control between half and full speed (fast) position, before stopping, may cause engine to "backfire".

- Turn ignition key (F) to "STOP" position and remove key. Always remove key when leaving tractor to prevent unauthorized use.
- Never use the choke to stop the engine.

IMPORTANT: LEAVING THE IGNITION SWITCH IN ANY POSITION OTHER THAN "STOP" WILL CAUSE THE BATTERY TO DISCHARGE AND GO DEAD.

NOTE: Under certain conditions when tractor is standing idle with the engine running, hot engine exhaust gases may cause "browning" of grass. To eliminate this possibility, always stop engine when stopping tractor on grass areas.



CAUTION: Always stop tractor completely, as described above, and set parking brake before leaving the operator's position.

TO USE THROTTLE CONTROL (D) (See Fig. 6)

Always operate engine at full speed (fast).

- Operating engine at less than full speed (fast) reduces engine's operating efficiency.
- Full speed (fast) offers the best mower performance.

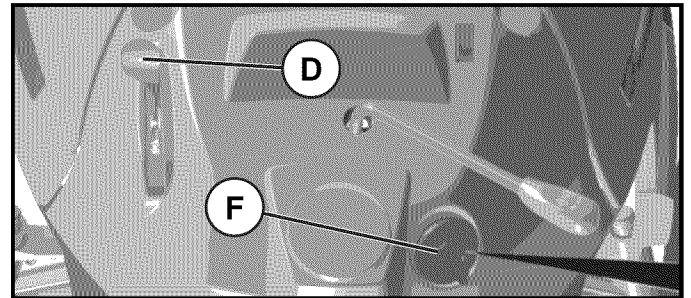

Fig. 6

TO MOVE FORWARD AND BACKWARD (See Fig. 7)

The direction and speed of movement is controlled by the motion control lever. (J)

- Start tractor with motion control lever in neutral position.
- Release parking brake.
- Slowly move motion control lever to desired position.

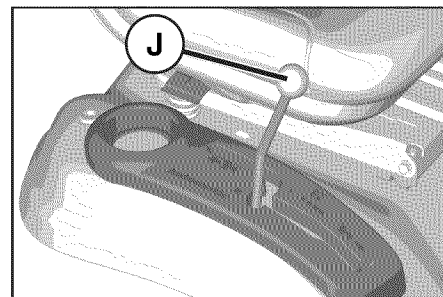

Fig. 7

OPERATION

TO ADJUST MOWER CUTTING HEIGHT

(See Fig. 8)

The position of the attachment lift lever (A) determines the cutting height.

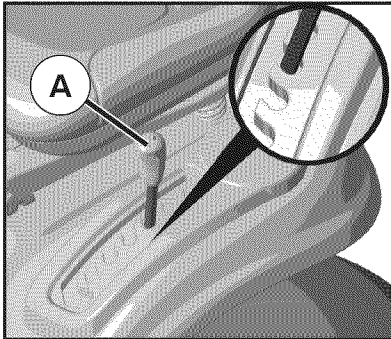

Fig. 8

- Put attachment lift lever in desired cutting height slot. The cutting height range is approximately 1" to 4". The heights are measured from the ground to the blade tip with the engine not running. These heights are approximate and may vary depending upon soil conditions, height of grass and types of grass being mowed.
- The average lawn should be cut to approximately 2-1/2" during the cool season and to over 3" during hot months. For healthier and better looking lawns, mow often and after moderate growth.
- For best cutting performance, grass over 6" in height should be mowed twice. Make the first cut relatively high; the second to desired height.

TO ADJUST GAUGE WHEELS (See Fig. 9)

Gauge wheels are properly adjusted when they are slightly off the ground when mower is at the desired cutting height in operating position. Gauge wheels then keep the deck in proper position to help prevent scalping in most terrain conditions.

NOTE: Adjust gauge wheels with tractor on a flat level surface.

- Adjust mower to desired cutting height (See "TO ADJUST MOWER CUTTING HEIGHT" in the Operation section of this manual).
- With mower in desired height of cut position, gauge wheels should be assembled so they are slightly off the ground. Install gauge wheel in appropriate hole as shown and tighten securely.
- Repeat for opposite side installing gauge wheel in same adjustment hole.

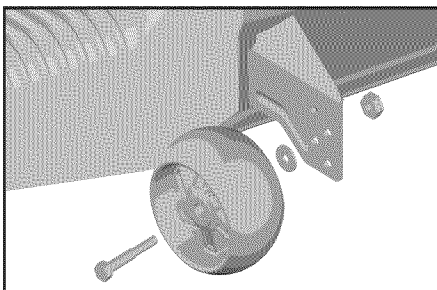

Fig. 9

TO OPERATE MOWER

Your tractor is equipped with an operator presence sensing switch. Any attempt by the operator to leave the seat with the engine running and the attachment clutch engaged will shut off the engine. You must remain fully and centrally positioned in the seat to prevent the engine from hesitating or cutting off when operating your equipment on rough, rolling terrain or hills.

- Select desired height of cut (see "TO ADJUST MOWER CUTTING HEIGHT")
- Start mower blades by engaging attachment clutch control.

TO STOP MOWER BLADES

Disengage attachment clutch control.



CAUTION: Do not operate the mower without either the entire grass catcher, on mowers so equipped, or the deflector shield (S) in place (See Fig. 10).

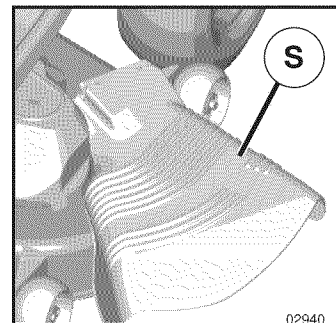

Fig. 10

TO TRANSPORT (See Figs. 11)

When pushing or towing your tractor, be sure to disengage transmission by placing freewheel control in freewheeling position. Free wheel control is located at the rear of tractor.

- Raise attachment lift to highest position with attachment lift control.
- Pull freewheel control out and into the slot and release so it is held in the disengaged position.
- Do not push or tow tractor at more than two (2) MPH.
- To reengage transmission, reverse above procedure.

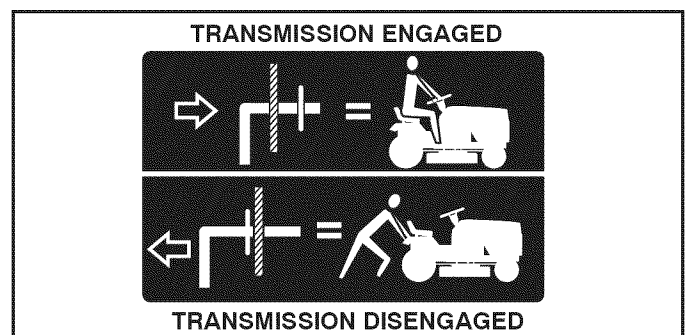

Fig. 11

NOTE: To protect hood from damage when transporting your tractor on a truck or a trailer, be sure hood is closed and secured to tractor. Use an appropriate means of tying hood to tractor (rope, cord, etc.).

OPERATION

TOWING CARTS & OTHER ATTACHMENTS

Tow only the attachments that are recommended by and comply with specifications of the manufacturer of your tractor. Use common sense when towing. Too heavy of a load, while on a slope, is dangerous. Tires can lose traction with the ground and cause you to lose control of your tractor.

REVERSE OPERATION SYSTEM (ROS)

Your tractor is equipped with a Reverse Operation System (ROS). Any attempt by the operator to travel in the reverse direction with the attachment clutch engaged will shut off the engine unless ignition key is placed in the ROS "ON" position.

⚠WARNING: Backing up with the attachment clutch engaged while mowing is strongly discouraged. Turning the ROS "ON", to allow reverse operation with the attachment clutch engaged, should only be done when the operator decides it is necessary to reposition the machine with the attachment engaged. **Do not mow in reverse unless absolutely necessary.**

USING THE REVERSE OPERATION SYSTEM (See Fig. 12)

Only use if you are certain no children or other bystanders will enter the mowing area.

- Move motion control lever to neutral (N) position.
- With engine running, turn ignition key counterclockwise to ROS "ON" position.
- Look down and behind before and while backing.
- Slowly move motion control lever to reverse (R) position to start movement.
- When use of the ROS is no longer needed, turn the ignition key clockwise to engine "ON" position.

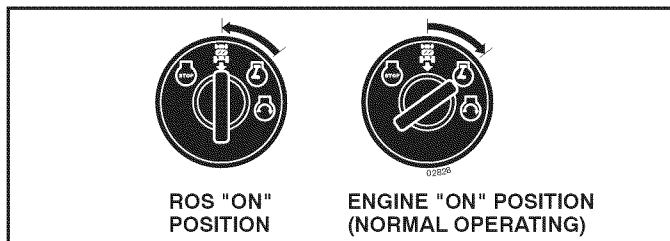

Fig. 12

TO OPERATE ON HILLS



CAUTION: Do not drive up or down hills with slopes greater than 15° and do not drive across any slope.

- Choose the slowest speed before starting up or down hills.
- Avoid stopping or changing speed on hills.
- If slowing is necessary, move throttle control lever to slower position.
- If stopping is absolutely necessary, push clutch/brake pedal quickly to brake position and engage parking brake.
- Move motion control lever to neutral position.

IMPORTANT: THE MOTION CONTROL LEVER DOES NOT RETURN TO NEUTRAL POSITION WHEN THE BRAKE PEDAL IS DEPRESSED.

- To restart movement, slowly release parking brake and clutch/brake pedal.
- Slowly move motion control lever to slowest setting.
- Make all turns slowly.

BEFORE STARTING THE ENGINE

CHECK ENGINE OIL LEVEL

The engine in your tractor has been shipped, from the factory, already filled with summer weight oil.

- Check engine oil with tractor on level ground.
- Remove oil fill cap/dipstick and wipe clean, reinsert the dipstick and screw cap tight, wait for a few seconds, remove and read oil level. If necessary, add oil until "FULL" mark on dipstick is reached. Do not overfill.
- For cold weather operation you should change oil for easier starting (See "OIL VISCOSITY CHART" in the Maintenance section of this manual).
- To change engine oil, see the Maintenance section in this manual.

ADD GASOLINE

- Fill fuel tank to bottom of filler neck. Do not overfill. Use fresh, clean, regular unleaded gasoline with a minimum of 87 octane. (Use of leaded gasoline will increase carbon and lead oxide deposits and reduce valve life). Do not mix oil with gasoline. Purchase fuel in quantities that can be used within 30 days to assure fuel freshness.



CAUTION: Wipe off any spilled oil or fuel. Do not store, spill or use gasoline near an open flame.

IMPORTANT: WHEN OPERATING IN TEMPERATURES BELOW 32°F (0°C), USE FRESH, CLEAN WINTER GRADE GASOLINE TO HELP ENSURE GOOD COLD WEATHER STARTING.

CAUTION: Alcohol blended fuels (called gasohol or using ethanol or methanol) can attract moisture which leads to separation and formation of acids during storage. Acidic gas can damage the fuel system of an engine while in storage. To avoid engine problems, the fuel system should be emptied before storage of 30 days or longer. Drain the gas tank, start the engine and let it run until the fuel lines and carburetor are empty. Use fresh fuel next season. See Storage Instructions for additional information. Never use engine or carburetor cleaner products in the fuel tank or permanent damage may occur.

TO START ENGINE (See Fig. 3)

When starting the engine for the first time or if the engine has run out of fuel, it will take extra cranking time to move fuel from the tank to the engine.

- Be sure freewheel control is in the transmission engaged position.
- Sit on seat in operating position, depress clutch/brake pedal and set parking brake.
- Place motion control lever in neutral position.
- Move attachment clutch to "DISENGAGED" position.
- Move throttle control to choke position.

NOTE: Before starting, read the warm and cold starting procedures that follow.

OPERATION

- Insert key into ignition and turn key clockwise to "START" position and release key as soon as engine starts. Do not run starter continuously for more than fifteen seconds per minute. If the engine does not start after several attempts, move throttle control to fast position, wait a few minutes and try again. If engine still does not start, move the throttle control back to the choke position and retry.

WARM WEATHER STARTING (50° F/10°C and above)

- When engine starts, move the throttle control to the fast position.
- The attachments and ground drive can now be used. If the engine does not accept the load, restart the engine and allow it to warm up for one minute using the choke as described above.

COLD WEATHER STARTING (50° F/10°C and below)

- When engine starts, allow engine to run with the throttle control in the choke position until the engine runs roughly, then move throttle control to fast position. This may require an engine warm-up period from several seconds to several minutes, depending on the temperature.

AUTOMATIC TRANSMISSION WARM UP

- Before driving the unit in cold weather, the transmission should be warmed up as follows:
 - Be sure the tractor is on level ground.
 - Place the motion control lever in neutral. Release the parking brake and let the clutch/brake slowly return to operating position.
 - Allow one minute for transmission to warm up. This can be done during the engine warm up period.
- The attachments can also be used during the engine warm-up period after the transmission has been warmed up.

NOTE: If at a high altitude (above 3000 feet) or in cold temperatures (below 32° F) the carburetor fuel mixture may need to be adjusted for best engine performance. See "TO ADJUST CARBURETOR" in the Service and Adjustments section of this manual.

PURGE TRANSMISSION



To ensure proper operation and performance, it is recommended that the transmission be purged before operating tractor for the first time. This procedure will remove any trapped air inside the transmission which may have developed during shipping of your tractor.

IMPORTANT: SHOULD YOUR TRANSMISSION REQUIRE REMOVAL FOR SERVICE OR REPLACEMENT, IT SHOULD BE PURGED AFTER REINSTALLATION BEFORE OPERATING THE TRACTOR.

1. Place tractor safely on a level surface - that is clear and open - with engine off and parking brake set.
2. Disengage transmission by placing freewheel control in freewheeling position (See "TO TRANSPORT" in this section of manual).
3. Sitting in the tractor seat, start engine. After the engine is running, move throttle control to slow position. With motion control lever in neutral position, slowly disengage clutch/brake pedal.



CAUTION: At any time, during step 4, there may be movement of the drive wheels.

4. Move motion control lever to full forward position and hold for five (5) seconds. Move lever to full reverse position and hold for five (5) seconds. Repeat this procedure three (3) times.
5. Move motion control lever to neutral position. Shut-off engine and set parking brake.
6. Engage transmission by placing freewheel control in engaged position (See "TO TRANSPORT" in this section of manual).
7. Sitting in the tractor seat, start engine. After the engine is running, move throttle control to half (1/2) speed. With motion control lever in neutral position, slowly disengage clutch/brake pedal.
8. Slowly move motion control lever forward, after the tractor moves approximately five (5) feet, slowly move motion control lever to reverse position. After the tractor moves approximately five (5) feet return the motion control lever to the neutral position. Repeat this procedure with the motion control lever three (3) times.

Your transmission is now purged and now ready for normal operation.

MOWING TIPS

- Tire chains cannot be used when the mower housing is attached to tractor.
- Mower should be properly leveled for best mowing performance. See "TO LEVEL MOWER HOUSING" in the Service and Adjustments section of this manual.
- The left hand side of mower should be used for trimming.
- Drive so that clippings are discharged onto the area that has been cut. Have the cut area to the right of the tractor. This will result in a more even distribution of clippings and more uniform cutting.
- When mowing large areas, start by turning to the right so that clippings will discharge away from shrubs, fences, driveways, etc. After one or two rounds, mow in the opposite direction making left hand turns until finished (See Fig. 13).

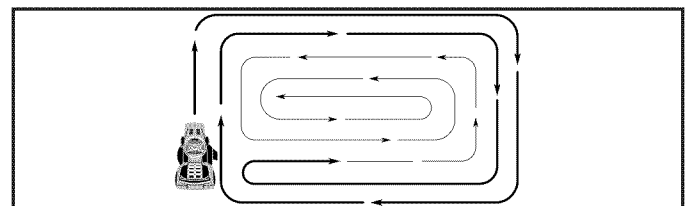

Fig. 13

- If grass is extremely tall, it should be mowed twice to reduce load and possible fire hazard from dried clippings. Make first cut relatively high; the second to the desired height.
- Do not mow grass when it is wet. Wet grass will plug mower and leave undesirable clumps. Allow grass to dry before mowing.
- **Always operate engine at full throttle when mowing** to assure better mowing performance and proper discharge of material. Regulate ground speed by selecting a low enough gear to give the mower cutting performance as well as the quality of cut desired.
- When operating attachments, select a ground speed that will suit the terrain and give best performance of the attachment being used.

MAINTENANCE

| MAINTENANCE SCHEDULE | | BEFORE EACH USE | EVERY 8 HOURS | EVERY 25 HOURS | EVERY 50 HOURS | EVERY 100 HOURS | EVERY SEASON | BEFORE STORAGE |
|----------------------|--|-----------------|---------------|------------------|------------------|------------------|--------------|----------------|
| TRACTOR | Check Brake Operation | ✓ | ✓ | | | | | |
| | Check Tire Pressure | ✓ | ✓ | | | | | |
| | Check Operator Presence & ROS Systems | ✓ | | | | | | |
| | Check for Loose Fasteners | ✓ | | | | ✓ | | ✓ |
| | Check/Replace Mower Blades | | | ✓ ³ | | | | |
| | Lubrication Chart | | | ✓ | | | | ✓ |
| | Check Battery Level | | | ✓ ⁴ | | | | |
| | Clean Battery and Terminals | | | ✓ | | | | ✓ |
| | Clean Debris Off Steering Plate | | | ✓ ⁵ | | | | |
| | Check Transaxle Cooling | | | ✓ | | | | |
| | Check Mower Levelness | | | | ✓ | | | |
| | Check V-Belts | | | | | ✓ | | |
| ENGINE | Check Engine Oil Level | ✓ | ✓ | | | | | |
| | Change Engine Oil (with oil filter) | | | | ✓ ^{1,2} | | | ✓ |
| | Change Engine Oil (without oil filter) | | | ✓ ^{1,2} | | | | ✓ |
| | Clean Air Filter | | | ✓ ² | | | | |
| | Clean Air Screen | | | ✓ ² | | | | |
| | Inspect Muffler/Spark Arrester | | | | ✓ | | | |
| | Replace Oil Filter (If equipped) | | | | | ✓ ^{1,2} | | |
| | Clean Engine Cooling Fins | | | | | ✓ ² | | |
| | Replace Spark Plug | | | | | ✓ | ✓ | |
| | Replace Air Filter Paper Cartridge | | | | | ✓ ² | | |
| | Replace Fuel Filter | | | | | | ✓ | |

1 - Change more often when operating under a heavy load or in high ambient temperatures.
2 - Service more often when operating in dirty or dusty conditions.

3 - Replace blades more often when mowing in sandy soil.
4 - Not required if equipped with maintenance-free battery.

5 - See Cleaning in Maintenance Section.

GENERAL RECOMMENDATIONS

The warranty on this tractor does not cover items that have been subjected to operator abuse or negligence. To receive full value from the warranty, operator must maintain tractor as instructed in this manual.

Some adjustments will need to be made periodically to properly maintain your tractor.

At least once a season, check to see if you should make any of the adjustments described in the Service and Adjustments section of this manual.

- At least once a year you should replace the spark plug, clean or replace air filter, and check blades and belts for wear. A new spark plug and clean air filter assure proper air-fuel mixture and help your engine run better and last longer.

BEFORE EACH USE

- Check engine oil level.
- Check brake operation.
- Check tire pressure.
- Check operator presence and ROS systems for proper operation.
- Check for loose fasteners.

LUBRICATION CHART

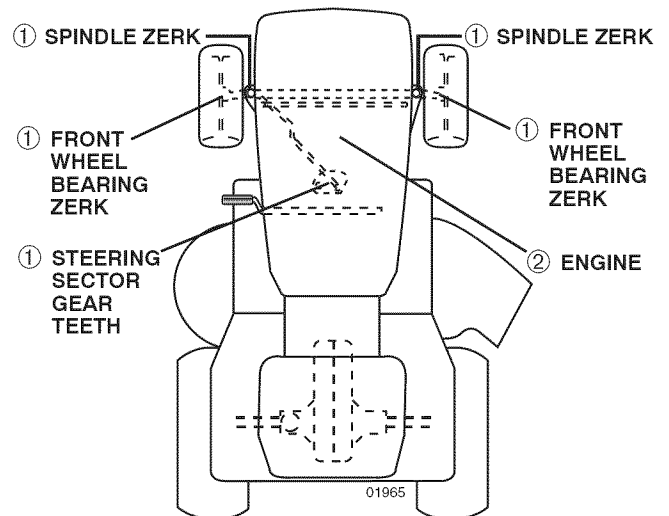

- ① General Purpose Grease
- ② Refer to Maintenance "ENGINE" Section

IMPORTANT: DO NOT OIL OR GREASE THE PIVOT POINTS WHICH HAVE SPECIAL NYLON BEARINGS. VISCOUS LUBRICANTS WILL ATTRACT DUST AND DIRT THAT WILL SHORTEN THE LIFE OF THE SELF-LUBRICATING BEARINGS. IF YOU FEEL THEY MUST BE LUBRICATED, USE ONLY A DRY, POWDERED GRAPHITE TYPE LUBRICANT SPARINGLY.

MAINTENANCE

TRACTOR

Always observe safety rules when performing any maintenance.

BRAKE OPERATION

If tractor requires more than five (5) feet to stop at highest speed in highest gear on a level, dry concrete or paved surface, then brake must be checked and adjusted. (See "TO CHECK BRAKE" in the Service and Adjustments section of this manual).

TIRES

- Maintain proper air pressure in all tires (See the sides of tires for proper PSI).
- Keep tires free of gasoline, oil, or insect control chemicals which can harm rubber.
- Avoid stumps, stones, deep ruts, sharp objects and other hazards that may cause tire damage.

NOTE: To seal tire punctures and prevent flat tires due to slow leaks, tire sealant may be purchased from your local parts dealer. Tire sealant also prevents tire dry rot and corrosion.

OPERATOR PRESENCE SYSTEM AND REVERSE OPERATION SYSTEM (ROS) (See Fig. 14)

Be sure operator presence and reverse operation systems are working properly. If your tractor does not function as described, repair the problem immediately.

- The engine should not start unless the brake pedal is fully depressed, and the attachment clutch control is in the disengaged position.

CHECK OPERATOR PRESENCE SYSTEM

- When the engine is running, any attempt by the operator to leave the seat without first setting the parking brake should shut off the engine.
- When the engine is running and the attachment clutch is engaged, any attempt by the operator to leave the seat should shut off the engine.
- The attachment clutch should never operate unless the operator is in the seat.

CHECK REVERSE OPERATION (ROS) SYSTEM

- When the engine is running with the ignition switch in the engine "ON" position and the attachment clutch engaged, any attempt by the operator to shift into reverse should shut off the engine.
- When the engine is running with the ignition switch in the ROS "ON" position and the attachment clutch engaged, any attempt by the operator to shift into reverse should NOT shut off the engine.

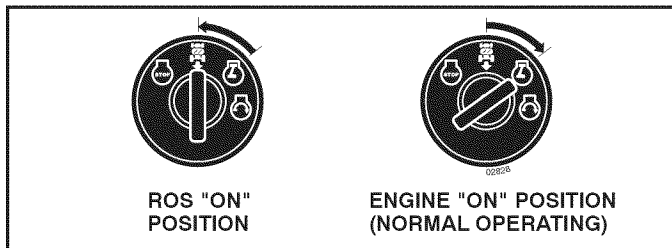

Fig. 14

BLADE CARE

For best results mower blades must be kept sharp. Replace bent or damaged blades.



CAUTION: Use only a replacement blade approved by the manufacturer of your tractor. Using a blade not approved by the manufacturer of your tractor is hazardous, could damage your tractor and void your warranty.

BLADE REMOVAL (See Fig. 15)

- Raise mower to highest position to allow access to blades.

NOTE: Protect your hands with gloves and/or wrap blade with heavy cloth.

- Remove blade bolt by turning counterclockwise.
- Install new or resharpened blade with stamped "THIS SIDE UP" facing deck and mandrel assembly.

IMPORTANT: TO ENSURE PROPER ASSEMBLY, CENTER HOLE IN BLADE MUST ALIGN WITH STAR ON MANDREL ASSEMBLY.

- Install and tighten blade bolt securely (45-55 Ft. Lbs. torque).

IMPORTANT: SPECIAL BLADE BOLT HEAT TREATED.

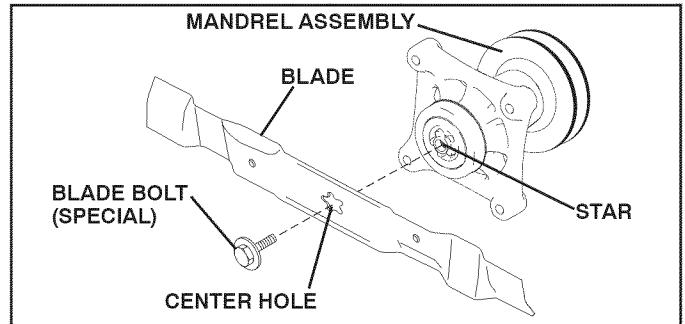

Fig. 15

BATTERY

Your tractor has a battery charging system which is sufficient for normal use. However, periodic charging of the battery with an automotive charger will extend its life.

- Keep battery and terminals clean.
- Keep battery bolts tight.
- Keep small vent holes open.
- Recharge at 6-10 amperes for 1 hour.

NOTE: The original equipment battery on your tractor is maintenance free. Do not attempt to open or remove caps or covers. Adding or checking level of electrolyte is not necessary.

TO CLEAN BATTERY AND TERMINALS

Corrosion and dirt on the battery and terminals can cause the battery to "leak" power.

- Disconnect BLACK battery cable first then RED battery cable and remove battery from tractor.
- Rinse the battery with plain water and dry.
- Clean terminals and battery cable ends with wire brush until bright.
- Coat terminals with grease or petroleum jelly.
- Reinstall battery (See "REPLACING BATTERY" in the SERVICE AND ADJUSTMENTS section of this manual).

V-BELTS

Check V-belts for deterioration and wear after 100 hours of operation and replace if necessary. The belts are not adjustable. Replace belts if they begin to slip from wear.

MAINTENANCE

TRANSAXLE MAINTENANCE

The transmission fan and cooling fins should be kept clean to assure proper cooling.

Do not attempt to clean fan or transmission while engine is running or while the transmission is hot. To prevent possible damage to seals, do not use high pressure water or steam to clean transmission.

- Inspect cooling fan to be sure fan blades are intact and clean.
- Inspect cooling fins for dirt, grass clippings and other materials. To prevent damage to seals, do not use compressed air or high pressure sprayer to clean cooling fins.

TRANSAXLE PUMP FLUID

The transaxle was sealed at the factory and fluid maintenance is not required for the life of the transaxle. Should the transaxle ever leak or require servicing, contact your nearest authorized service center/department.

ENGINE

LUBRICATION

Only use high quality detergent oil rated with API service classification SG-SL. Select the oil's SAE viscosity grade according to your expected operating temperature.

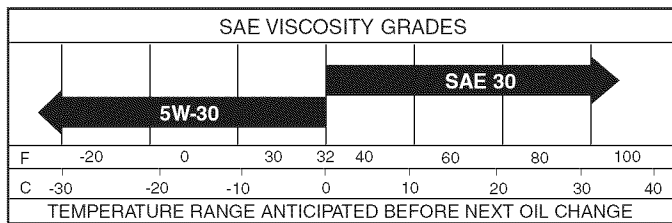

NOTE: Although multi-viscosity oils (5W30, 10W30 etc.) improve starting in cold weather, they will result in increased oil consumption when used above 32°F. Check your engine oil level more frequently to avoid possible engine damage from running low on oil.

Change the oil after every 50 hours of operation or at least once a year if the tractor is not used for 50 hours in one year.

Check the crankcase oil level before starting the engine and after each eight (8) hours of operation. Tighten oil fill cap/dipstick securely each time you check the oil level.

TO CHANGE ENGINE OIL (See Fig. 16)

Determine temperature range expected before oil change. All oil must meet API service classification SG-SL.

- Be sure tractor is on level surface.
- Oil will drain more freely when warm.
- Catch oil in a suitable container.
- Remove oil fill cap/dipstick. Be careful not to allow dirt to enter the engine when changing oil.
- Remove yellow cap from end of drain valve and install the drain tube onto the fitting.
- Unlock drain valve by pushing inward and turning counterclockwise.
- To open, pull out on the drain valve.
- After oil has drained completely, close and lock the drain valve by pushing inward and turning clockwise until the pin is in the locked position as shown.

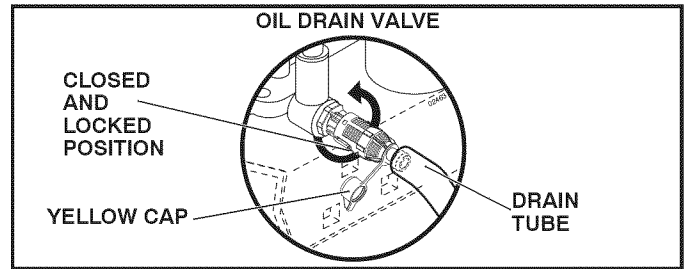

Fig. 16

- Remove the drain tube and replace the cap onto to the bottom fitting of the drain valve.
- Refill engine with oil through oil fill dipstick tube. Pour slowly. Do not overfill. For approximate capacity see "PRODUCT SPECIFICATIONS" section of this manual.
- Use gauge on oil fill cap/dipstick for checking level. Be sure dipstick cap is tightened securely for accurate reading. Keep oil at "FULL" line on dipstick. Tighten cap onto the tube securely when finished.

ENGINE OIL FILTER

Replace the engine oil filter every season or every other oil change if the tractor is used more than 100 hours in one year.

AIR FILTER

Your engine will not run properly using a dirty air filter. Service air cleaner more often under dusty conditions.

CLEAN AIR SCREEN

Air screen must be kept free of dirt and chaff to prevent engine damage from overheating. Clean with a wire brush or compressed air to remove dirt and stubborn dried gum fibers.

ENGINE COOLING SYSTEM (See Fig. 17)

Debris may clog the engine's air cooling system. Remove blower housing and clean the area shown to prevent overheating and engine damage.

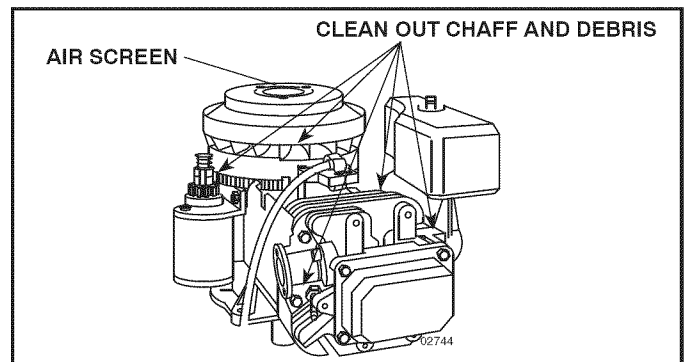

Fig. 17

MUFFLER

Inspect and replace corroded muffler and spark arrester (if equipped) as it could create a fire hazard and/or damage.

SPARK PLUGS

Replace spark plugs at the beginning of each mowing season or after every 100 hours of operation, whichever occurs first. Spark plug type and gap setting are shown in "PRODUCT SPECIFICATIONS" section of this manual.

MAINTENANCE

IN-LINE FUEL FILTER (See Fig. 18)

The fuel filter should be replaced once each season. If fuel filter becomes clogged, obstructing fuel flow to carburetor, replacement is required.

- With engine cool, remove filter and plug fuel line sections.
- Place new fuel filter in position in fuel line with arrow pointing towards carburetor.
- Be sure there are no fuel line leaks and clamps are properly positioned.
- Immediately wipe up any spilled gasoline.

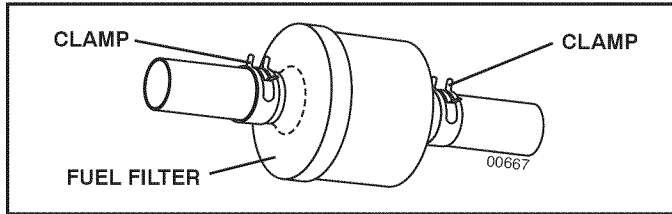

Fig. 18

CLEANING

- Clean engine, battery, seat, finish, etc. of all foreign matter.
- Clean debris from steering plate. Debris can restrict clutch/brake pedal shaft movement, causing belt slip and loss of drive.



CAUTION: Avoid all pinch points and movable parts (See Fig. 19)

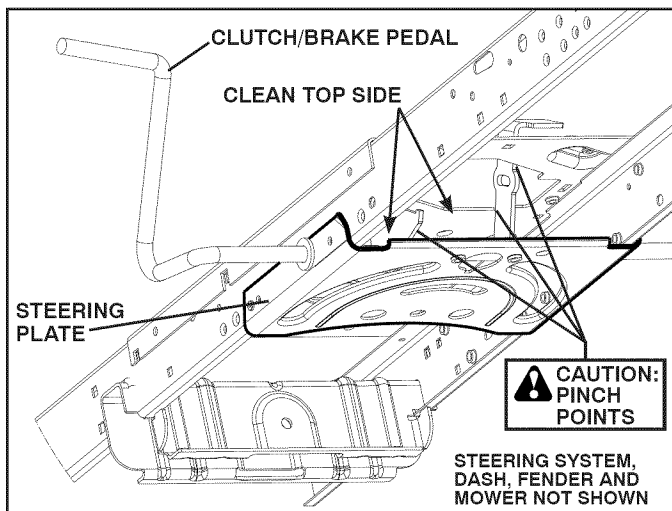

Fig. 19

- Keep finished surfaces and wheels free of all gasoline, oil, etc.
- Protect painted surfaces with automotive type wax.

We do not recommend using a garden hose or pressure washer to clean your tractor unless the engine and transmission are covered to keep water out. Water in engine or transmission will shorten the useful life of your tractor. Use compressed air or a leaf blower to remove grass, leaves and trash from tractor and mower.

DECK WASHOUT PORT (See Fig. 20)

Your tractor's deck is equipped with a washout port on its surface as part of its deck wash system. It should be utilized after each use.

1. Drive the tractor to a level, clear spot on your lawn, near enough to a water spigot for your garden hose to reach.

IMPORTANT: Make certain the tractor's discharge chute is directed AWAY from your house, garage, parked cars, etc. Remove bagger chute or mulch cover if attached.

2. Make sure the attachment clutch control is in the "DISENGAGED" position, set the parking brake, and stop the engine.
3. Thread the nozzle adapter (packaged with your tractor's Operator's Manual) onto the end of your garden hose.
4. Pull back the lock collar of the nozzle adapter and push the adapter onto the deck washout port at the left end of the mower deck. Release the lock collar to lock the adapter on the nozzle.

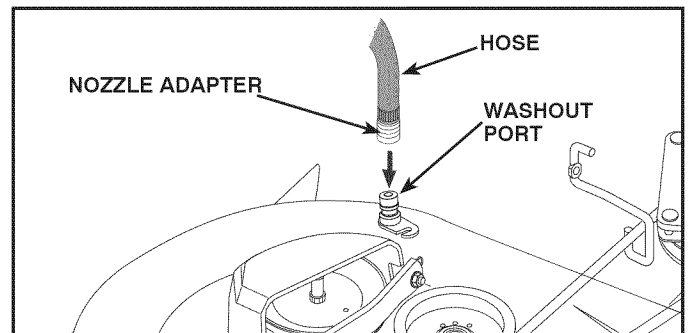

Fig. 20

IMPORTANT: Tug hose ensuring connection is secure.

5. Turn the water on.
6. While sitting in the operator's position on the tractor, re-start the engine and place the throttle lever in the Fast "F" position.

IMPORTANT: Recheck the area making certain the area is clear.

7. Move the tractor's attachment clutch control to the "ENGAGED" position. Remain in the operator's position with the cutting deck engaged until the deck is cleaned.
8. Move the tractor's attachment clutch control to the "DISENGAGED" position. Turn the ignition key to the STOP position to turn the tractor's engine off. Turn the water off.
9. Pull back the lock collar of the nozzle adapter to disconnect the adapter from the nozzle washout port.
10. Move the tractor to a dry area, preferably a concrete or paved area. Place the attachment clutch control in the "ENGAGED" position to remove excess water and to help dry before putting the tractor away.



WARNING: A broken or missing washout fitting could expose you or others to thrown objects from contact with the blade.

- Replace broken or missing washout fitting immediately, prior to using mower again.
- Plug any holes in mower with bolts and locknuts.

SERVICE AND ADJUSTMENTS



WARNING: TO AVOID SERIOUS INJURY, BEFORE PERFORMING ANY SERVICE OR ADJUSTMENTS:

- Depress brake pedal fully and set parking brake.
- Place motion control lever in neutral position.
- Place attachment clutch in "DISENGAGED" position.
- Turn ignition key to "STOP" and remove key.
- Make sure the blades and all moving parts have completely stopped.
- Disconnect spark plug wire from spark plug and place wire where it cannot come in contact with plug.

TO REMOVE MOWER (See Fig. 21)

- Place attachment clutch in "DISENGAGED" position.
- Lower attachment lift lever to its lowest position.
- Roll belt off engine pulley (M) and belt keepers (G).
- Remove retainer spring (K), slide collar (L) off and push housing guide (P) out of bracket.
- Remove clutch cable spring (Q) from idler arm (R).
- Disconnect front link (E) from mower - remove retainer spring and washer.
- Go to either side of mower and disconnect mower suspension arm (A) from chassis pin (B) and rear lift link (C) from rear mower bracket (D) - remove retainer springs and washers.



CAUTION: AFTER REAR LIFT LINKS ARE DISCONNECTED, THE ATTACHMENT LIFT LEVER WILL BE SPRING LOADED. HAVE A TIGHT GRIP ON LIFT LEVER WHEN CHANGING POSITION OF THE LEVER.

- Slide mower out from under right side of tractor.

IMPORTANT: IF AN ATTACHMENT OTHER THAN THE MOWER IS TO BE MOUNTED ON THE TRACTOR, REMOVE THE FRONT LINK (E) AND REAR LIFT LINKS (C) FROM TRACTOR AND HOOK THE CLUTCH SPRING (Q) INTO THE CABLE GUIDE ON FRONT EDGE OF LOWER DASH.

TO INSTALL MOWER (See Fig. 21 - 26)

Be sure tractor is on level surface and engage parking brake.

- Lower attachment lift lever to its lowest position.



CAUTION: LIFT LEVER IS SPRING LOADED. HAVE A TIGHT GRIP ON LIFT LEVER, LOWER IT SLOWLY AND ENGAGE IN LOWEST POSITION.

NOTE: Be sure mower side suspension arms (A) are pointing forward before sliding mower under tractor.

- Slide mower under tractor until it is centered under tractor.

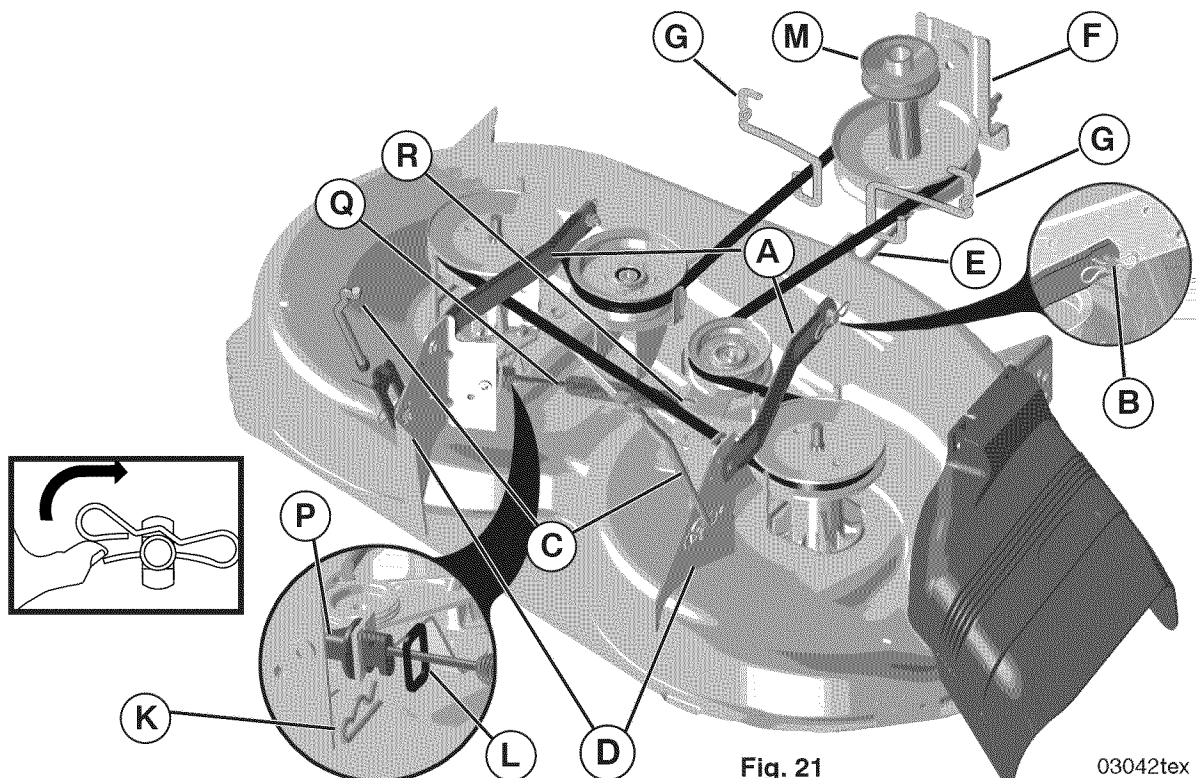

Fig. 21

03042tex

SERVICE AND ADJUSTMENTS

- ATTACH MOWER SIDE SUSPENSION ARMS (A) TO CHASSIS - Position hole in arm over pin (B) on outside of tractor chassis and secure with retainer spring.
- Repeat on opposite side of tractor.

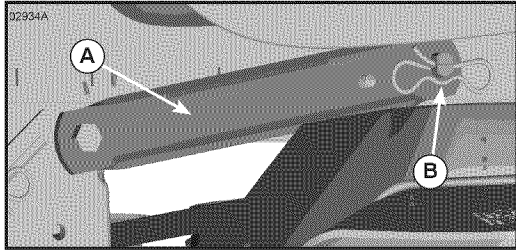

Fig. 22

- ATTACH REAR LIFT LINKS (C) - Lift rear corner of mower and position slot in link assembly over pin (D) on rear mower bracket and secure with washer and retainer spring.

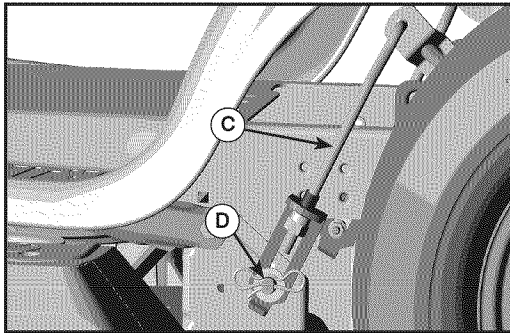

Fig. 23

- ATTACH FRONT LINK (E) - Work from left side of tractor. Insert rod end of link assembly through front hole in tractor front suspension bracket (F).

- Insert end of link (E) into hole in front mower bracket and secure with washer and retainer spring (J).

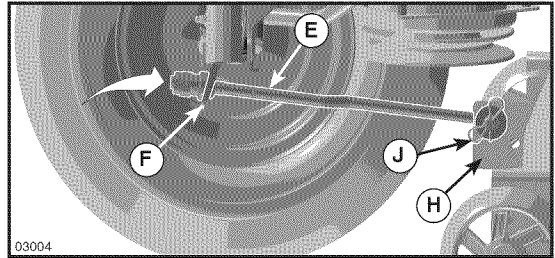

Fig. 24

- Hook end of clutch cable spring (Q) into hole in idler arm (R).
- Push clutch cable housing guide (P) into bracket, slide collar (L) onto guide and secure with retainer spring (K).
- Install belt on engine pulley (M), in belt keepers (G).

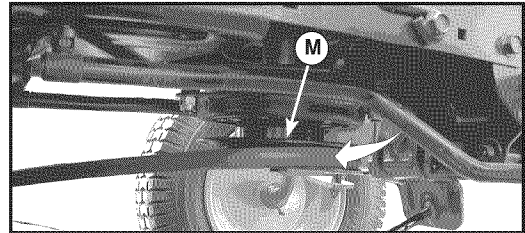

Fig. 25

IMPORTANT: CHECK BELT FOR PROPER ROUTING IN ALL MOWER PULLEY GROOVES.

- Raise attachment lift lever to highest position.
- If necessary, adjust gauge wheels before operating mower as shown in the Operation section of this manual.

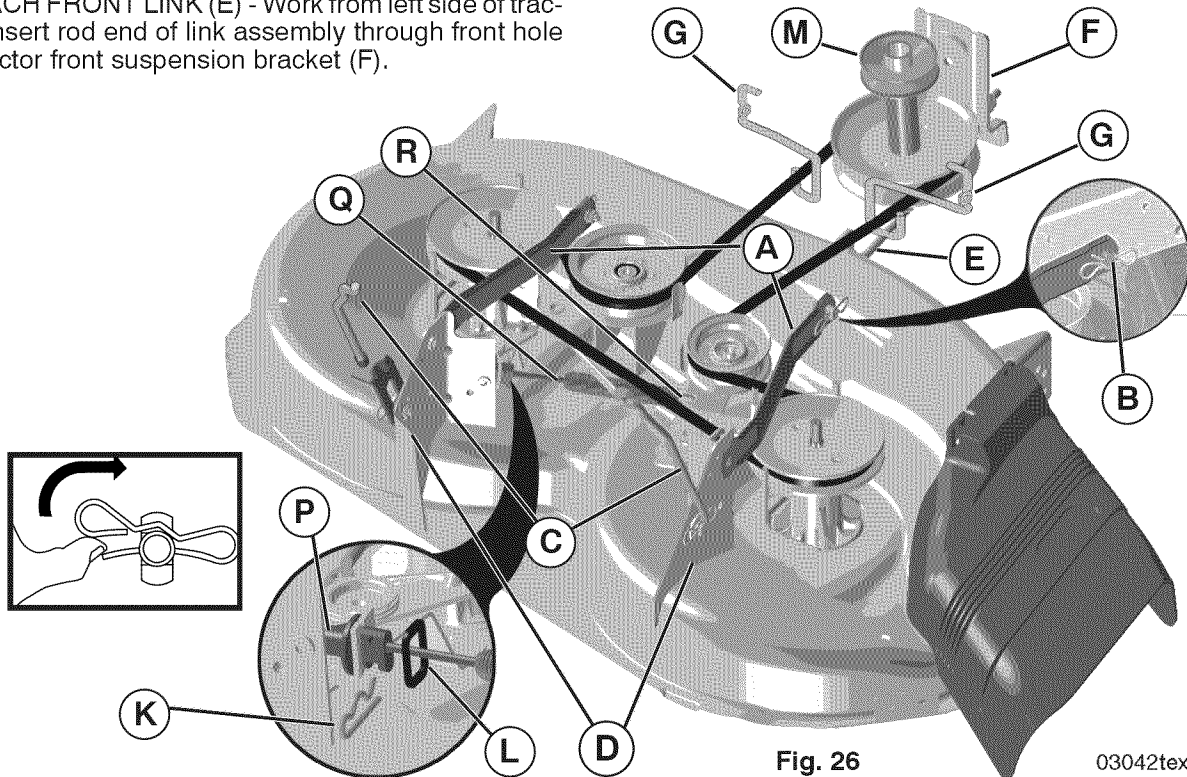

Fig. 26

03042tex

SERVICE AND ADJUSTMENTS

TO LEVEL MOWER

Make sure tires are properly inflated to the PSI shown on tires. If tires are over or under inflated, it may affect the appearance of your lawn and lead you to think the mower is not adjusted properly.

VISUAL SIDE-TO-SIDE ADJUSTMENT (See Fig. 27)

- With all tires properly inflated and if your lawn appears unevenly cut, determine which side of mower is cutting lower.
- With a 3/4" or adjustable wrench, turn lift link adjustment nut (A) to the left to lower LH side of mower, or, to the right to raise LH side of mower.

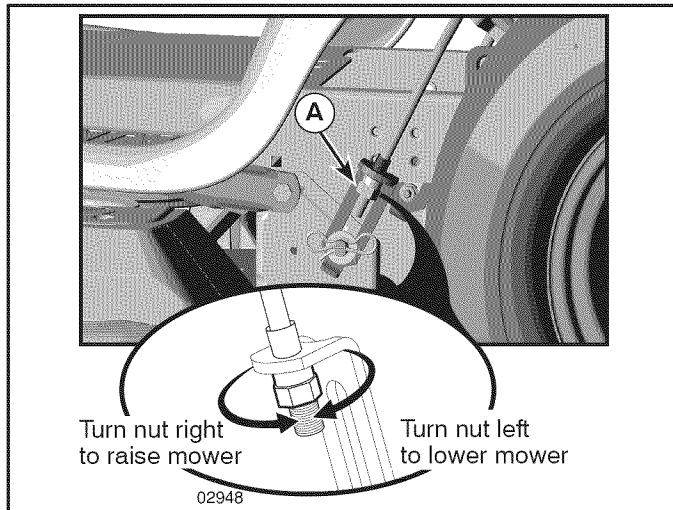

Fig. 27

NOTE: Each full turn of adjustment nut will change mower height about 3/16".

- Test your adjustment by mowing some uncut grass and visually checking the appearance. Readjust, if necessary, until you are satisfied with the results.

PRECISION SIDE-TO-SIDE ADJUSTMENT (See Fig. 28)

- With all tires properly inflated, park tractor on level ground or driveway.

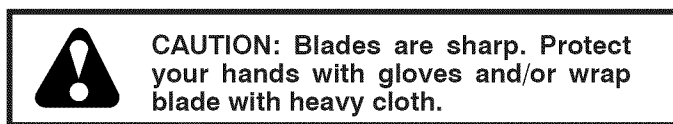

- Raise mower to its highest position.
- At both sides of mower, position blade at side and measure the distance (A) from bottom edge of blade to the ground. The distance should be the same on both sides.

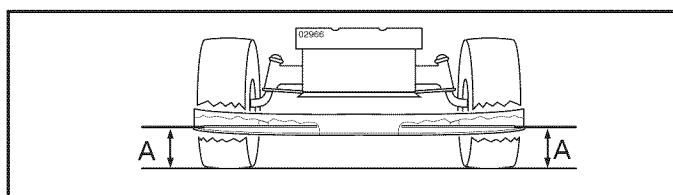

Fig. 28

- If adjustment is necessary, see step in Visual Adjustment instructions above.
- Recheck measurements, adjust if necessary until both sides are equal.

FRONT-TO-BACK ADJUSTMENT (See Fig. 29 & 30)

IMPORTANT: Deck must be level side-to-side.

To obtain the best cutting results, the mower blades should be adjusted so the front tip is 1/8" to 1/2" lower than the rear tip when the mower is in its highest position.

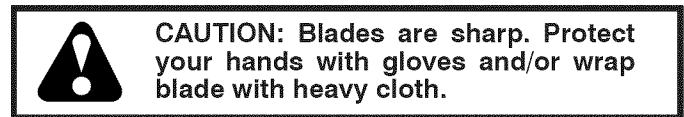

- Raise mower to highest position.
- Position blade so the tip is pointing straight forward. Measure distance (B) to the ground at front and rear tip of the blade.

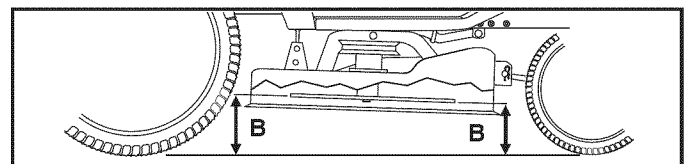

Fig. 29

- If front tip of blade is not 1/8" to 1/2" lower than the rear tip, go to the front of tractor.
- With an 11/16" or adjustable wrench, loosen jam nut A several turns to clear adjustment nut B.
- With a 3/4" or adjustable wrench, turn front link adjustment nut (B) clockwise (tighten) to raise the front of mower, or, counterclockwise (loosen) to lower the front mower.

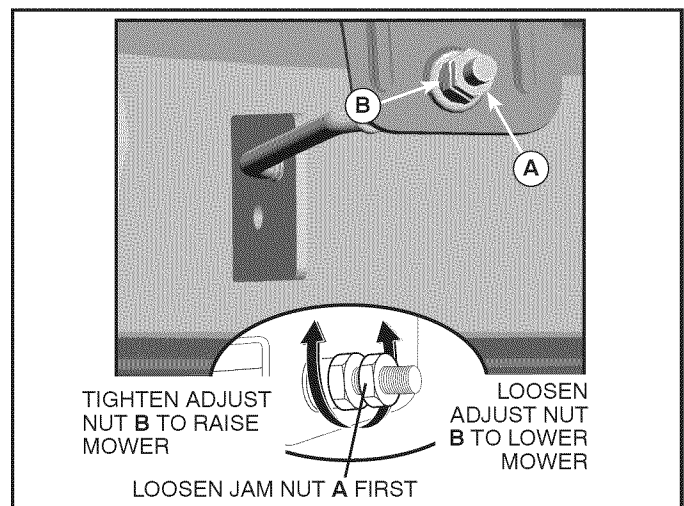

Fig. 30

NOTE: Each full turn of the adjustment nut will change mower height about 1/8".

- Recheck measurements, adjust if necessary until front tip of blade is 1/8" to 1/2" lower than the rear tip.
- Hold adjustment nut in position with wrench and tighten jam nut securely against adjustment nut.

SERVICE AND ADJUSTMENTS

TO REPLACE MOWER BLADE DRIVE BELT (See Fig. 31)

The mower blade drive belt may be replaced without tools. Park the tractor on level surface. Engage parking brake.

BELT REMOVAL -

- Remove mower from tractor (See "TO REMOVE MOWER" in this section of manual).
- Work belt off both mandrel pulleys and idler pulleys.
- Pull belt away from mower.

BELT INSTALLATION -

- Work belt around both mandrel pulleys and idler pulleys.
- Make sure belt is in all pulley grooves and inside all belt guides.
- Install mower (See "TO INSTALL MOWER" in this section of manual).

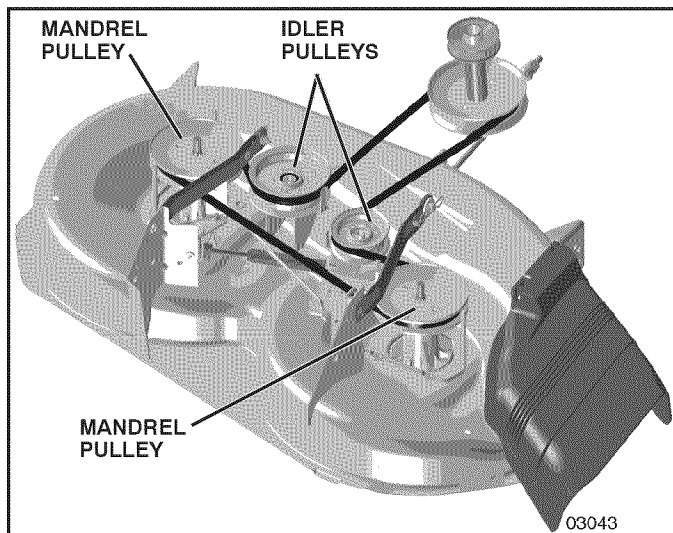

FIG. 31

TO CHECK BRAKE

If tractor requires more than five (5) feet to stop at highest speed in highest gear on a level, dry concrete or paved surface, then brake must be serviced.

You may also check brake by:

1. Park tractor on a level, dry concrete or paved surface, depress brake pedal all the way down and engage parking brake.
2. Disengage transmission by placing freewheel control in "transmission disengaged" position. Pull freewheel control out and into the slot and release so it is held in the disengaged position.

The rear wheels must lock and skid when you try to manually push the tractor forward. If the rear wheels rotate, then the brake needs to be serviced. Contact a qualified service center.

TO REPLACE MOTION DRIVE BELT (See Fig. 32)

Park the tractor on level surface. Engage parking brake. For assistance, there is a belt installation guide decal on bottom side of left footrest.

BELT REMOVAL -

- Remove mower (See "TO REMOVE MOWER" section in this manual).

NOTE: Observe entire motion drive belt and position of all belt guides and keepers.

- Remove belt from stationary idler (A) and clutching idler (B).
- Pull belt slack toward rear of tractor. Carefully remove belt upwards from transmission input pulley and over cooling fan blades (D).
- Remove belt downward from engine pulley (E).
- Slide belt toward rear of tractor, off the steering plate (F) and remove from tractor.

BELT INSTALLATION -

- Install new belt from tractor rear to front, over the steering plate (F) and above clutch brake pedal shaft (G).
- Pull belt toward front of tractor and roll belt onto engine pulley (E).
- Pull belt toward rear of tractor. Carefully work belt down around transmission cooling fan and onto the input pulley (D). Be sure belt is inside the belt keeper.
- Install belt through stationary idler (A) and clutching idler (B).
- Make sure belt is in all pulley grooves and inside all belt guides and keepers.
- Install mower (See "TO INSTALL MOWER" section in this manual).

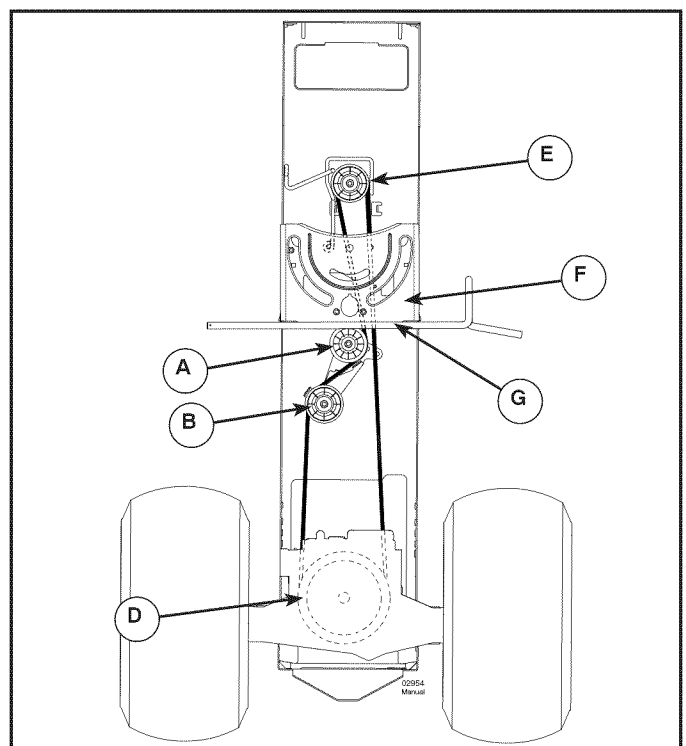

Fig. 32

SERVICE AND ADJUSTMENTS

TRANSAXLE MOTION CONTROL LEVER NEUTRAL ADJUSTMENT (See Fig. 33)

The motion control lever has been preset at the factory and adjustment should not be necessary.

- Loosen adjustment bolt in front of the right rear wheel, and lightly tighten.
- Start engine and move motion control lever until tractor does not move forward or backward.
- Hold motion control lever in that position and turn engine off.
- While holding motion control lever in place, loosen the adjustment bolt.
- Move motion control lever to the neutral (lock gate) position.
- Tighten adjustment bolt securely.

NOTE: If additional clearance is needed to get to adjustment bolt, move mower deck height to the lowest position.

After above adjustment is made, if the tractor still creeps forward or backward while motion control lever is in neutral position, follow these steps:

- Loosen the adjustment bolt.
- Move the motion control lever 1/4 to 1/2 inch in the direction it is trying to creep.
- Tighten adjustment bolt securely.
- Start engine and test.
- If tractor still creeps, repeat above steps until satisfied.

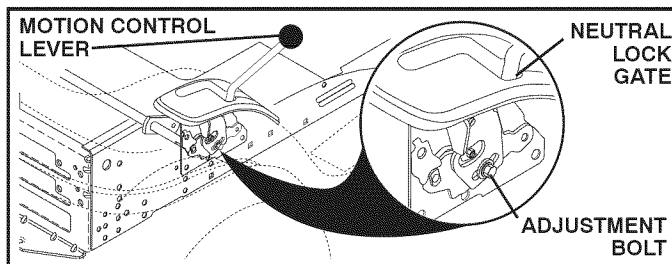

Fig. 33

TO REMOVE WHEEL (See Fig. 34)

- Block up axle securely.
- Remove axle cover, retaining ring and washers to allow wheel removal (rear wheel contains a square key - Do not lose).
- Repair tire and reassemble.
- On rear wheels only: align grooves in rear wheel hub and axle. Insert square key.
- Replace washers and snap retaining ring securely in axle groove.
- Replace axle cover.

NOTE: To seal tire punctures and prevent flat tires due to slow leaks, tire sealant may be purchased from your local parts dealer. Tire sealant also prevents tire dry rot and corrosion.

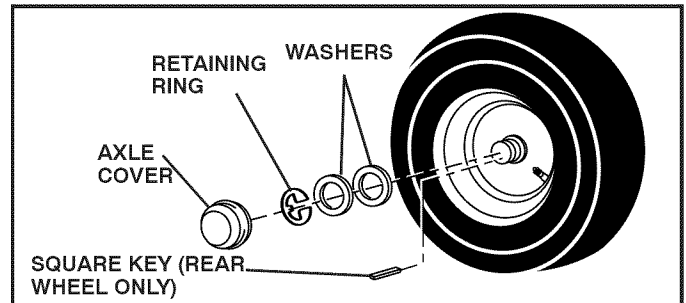

Fig. 34

FRONT WHEEL TOE-IN/CAMBER

Your new tractor front wheel toe-in and camber is set at the factory and is normal. The front wheel toe-in and camber are not adjustable. If damage has occurred to affect the factory set front wheel toe-in or camber, contact a qualified service center.

TO START ENGINE WITH A WEAK BATTERY (See Fig. 35)



WARNING: Lead-acid batteries generate explosive gases. Keep sparks, flame and smoking materials away from batteries. Always wear eye protection when around batteries.

If your battery is too weak to start the engine, it should be recharged. (See "BATTERY" in the MAINTENANCE section of this manual).

If "jumper cables" are used for emergency starting, follow this procedure:

IMPORTANT: YOUR TRACTOR IS EQUIPPED WITH A 12 VOLT SYSTEM. THE OTHER VEHICLE MUST ALSO BE A 12 VOLT SYSTEM. DO NOT USE YOUR TRACTOR BATTERY TO START OTHER VEHICLES.

TO ATTACH JUMPER CABLES -

- Connect one end of the RED cable to the POSITIVE (+) terminal of each battery(A-B), taking care not to short against tractor chassis.
- Connect one end of the BLACK cable to the NEGATIVE (-) terminal (C) of fully charged battery.
- Connect the other end of the BLACK cable (D) to good chassis ground, away from fuel tank and battery.

TO REMOVE CABLES, REVERSE ORDER -

- BLACK cable first from chassis and then from the fully charged battery.
- RED cable last from both batteries.

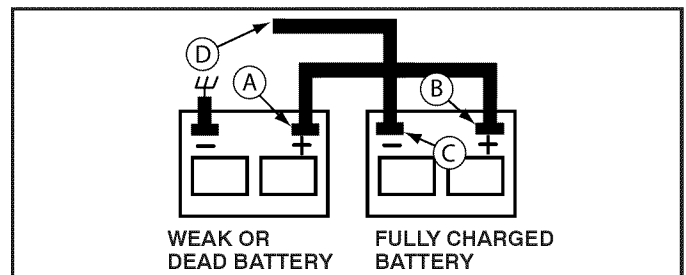

Fig. 35

SERVICE AND ADJUSTMENTS

REPLACING BATTERY (See Fig. 36)



WARNING: Do not short battery terminals by allowing a wrench or any other object to contact both terminals at the same time. Before connecting battery, remove metal bracelets, wristwatch bands, rings, etc. Positive terminal must be connected first to prevent sparking from accidental grounding.

- Lift seat pan to raised position.
- Disconnect BLACK battery cable first then RED battery cable and carefully remove battery from tractor.
- Install new battery with terminals in same position as old battery.
- First connect RED battery cable to positive (+) terminal with bolt and nut as shown. Tighten securely. Slide terminal cover over terminal.
- Connect BLACK grounding cable to negative (-) terminal with remaining bolt and nut. Tighten securely.
- Lower seat pan.

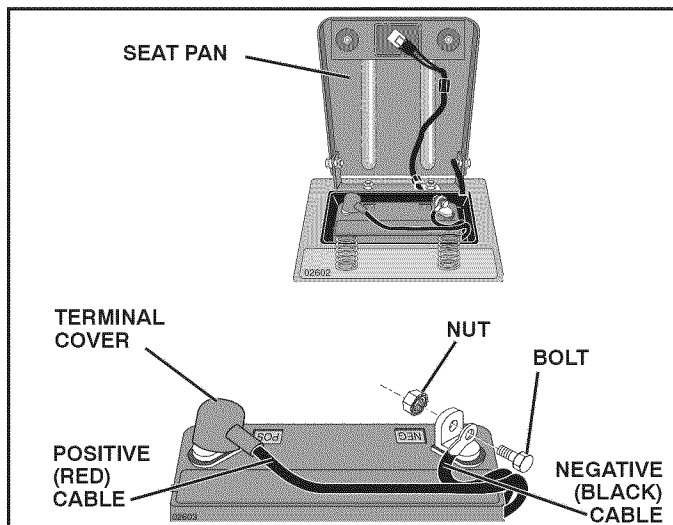

Fig. 36

TO REPLACE HEADLIGHT BULB

- Raise hood.
- Pull bulb holder out of the hole in the backside of the grill.
- Replace bulb in holder and push bulb holder securely back into the hole in the backside of the grill.
- Close hood.

INTERLOCKS AND RELAYS

Loose or damaged wiring may cause your tractor to run poorly, stop running, or prevent it from starting.

- Check wiring. See electrical wiring diagram in the Repair Parts section.

TO REPLACE FUSE

Replace with 20 amp automotive-type plug-in fuse. The fuse holder is located behind the dash.

TO REMOVE HOOD AND GRILL ASSEMBLY (See Fig. 37)

- Raise hood.
- Unsnap headlight wire connector.
- Stand in front of tractor. Grasp hood at sides, tilt toward engine and lift off of tractor.
- To replace, reverse above procedure.

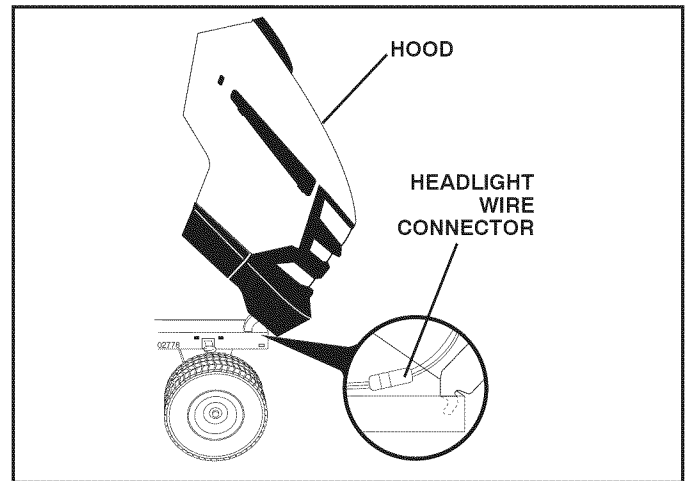

Fig. 37

TRANSMISSION

REMOVAL/REPLACEMENT

Should your transmission require removal for service or replacement, it should be purged after reinstallation and before operating the tractor. See "PURGE TRANSMISSION" in the Operation section of this manual.

ENGINE

TO ADJUST THROTTLE CONTROL CABLE

The throttle control has been preset at the factory and adjustment should not be necessary. If adjustment is necessary, see engine manual.

TO ADJUST CHOKE CONTROL

The choke control has been preset at the factory and adjustment should not be necessary. If adjustment is necessary, see engine manual.

TO ADJUST CARBURETOR

Your carburetor is not adjustable. If your engine does not operate properly due to suspected carburetor problems, take your tractor to an authorized service center for repair and/or adjustment.

STORAGE

Immediately prepare your tractor for storage at the end of the season or if the tractor will not be used for 30 days or more.



WARNING: Never store the tractor with gasoline in the tank inside a building where fumes may reach an open flame or spark. Allow the engine to cool before storing in any enclosure.

TRACTOR

Remove mower from tractor for winter storage. When mower is to be stored for a period of time, clean it thoroughly, remove all dirt, grease, leaves, etc. Store in a clean, dry area.

- Clean entire tractor (See "CLEANING" in the Maintenance section of this manual).
- Inspect and replace belts, if necessary (See belt replacement instructions in the Service and Adjustments section of this manual).
- Lubricate as shown in the Maintenance section of this manual.
- Be sure that all nuts, bolts and screws are securely fastened. Inspect moving parts for damage, breakage and wear. Replace if necessary.
- Touch up all rusted or chipped paint surfaces; sand lightly before painting.

BATTERY

- Fully charge the battery for storage.
- After a period of time in storage, battery may require recharging.
- To help prevent corrosion and power leakage during long periods of storage, battery cables should be disconnected and battery cleaned thoroughly (see "TO CLEAN BATTERY AND TERMINALS" in the Maintenance section of this manual).
- After cleaning, leave cables disconnected and place cables where they cannot come in contact with battery terminals.
- If battery is removed from tractor for storage, do not store battery directly on concrete or damp surfaces.

ENGINE

FUEL SYSTEM

IMPORTANT: IT IS IMPORTANT TO PREVENT GUM DEPOSITS FROM FORMING IN ESSENTIAL FUEL SYSTEM PARTS SUCH AS CARBURETOR, FUEL FILTER, FUEL HOSE, OR TANK DURING STORAGE. ALSO, EXPERIENCE INDICATES THAT ALCOHOL BLENDED FUELS (CALLED GASOHOL OR USING ETHANOL OR METHANOL) CAN ATTRACT MOISTURE WHICH LEADS TO SEPARATION AND FORMATION OF ACIDS DURING STORAGE. ACIDIC GAS CAN DAMAGE THE FUEL SYSTEM OF AN ENGINE WHILE IN STORAGE.

- Empty the fuel tank by starting the engine and let it run until the fuel lines and carburetor are empty.
- Never use engine or carburetor cleaner products in the fuel tank or permanent damage may occur.
- Use fresh fuel next season.

NOTE: Fuel stabilizer is an acceptable alternative in minimizing the formation of fuel gum deposits during storage. Add stabilizer to gasoline in fuel tank or storage container. Always follow the mix ratio found on stabilizer container. Run engine at least 10 minutes after adding stabilizer to allow the stabilizer to reach the carburetor. Do not empty the gas tank and carburetor if using fuel stabilizer.

ENGINE OIL

Drain oil (with engine warm) and replace with clean engine oil. (See "ENGINE" in the Maintenance section of this manual).

CYLINDER(S)

- Remove spark plug(s).
- Pour one ounce of oil through spark plug hole(s) into cylinder(s).
- Turn ignition key to "START" position for a few seconds to distribute oil.
- Replace with new spark plug(s).

OTHER

- Do not store gasoline from one season to another.
- Replace your gasoline can if your can starts to rust. Rust and/or dirt in your gasoline will cause problems.
- If possible, store your tractor indoors and cover it to give protection from dust and dirt.
- Cover your tractor with a suitable protective cover that does not retain moisture. Do not use plastic. Plastic cannot breathe which allows condensation to form and will cause your tractor to rust.

IMPORTANT: NEVER COVER TRACTOR WHILE ENGINE AND EXHAUST AREAS ARE STILL WARM.

TROUBLESHOOTING

| PROBLEM | CAUSE | CORRECTION |
|---|--|---|
| Will not start | <ol style="list-style-type: none"> 1. Out of fuel. 2. Engine not "CHOKED" properly. 3. Engine flooded. 4. Bad spark plug. 5. Dirty air filter. 6. Dirty fuel filter. 7. Water in fuel. 8. Loose or damaged wiring. 9. Carburetor out of adjustment. 10. Engine valves out of adjustment. | <ol style="list-style-type: none"> 1. Fill fuel tank. 2. See "TO START ENGINE" in Operation section. 3. Wait several minutes before attempting to start. 4. Replace spark plug. 5. Clean/replace air filter. 6. Replace fuel filter. 7. Empty fuel tank and carburetor, refill tank with fresh gasoline and replace fuel filter. 8. Check all wiring. 9. See "To Adjust Carburetor" in Service Adjustments section. 10. Contact an authorized service center/department. |
| Hard to start | <ol style="list-style-type: none"> 1. Dirty air filter. 2. Bad spark plug. 3. Weak or dead battery. 4. Dirty fuel filter. 5. Stale or dirty fuel. 6. Loose or damaged wiring. 7. Carburetor out of adjustment. 8. Engine valves out of adjustment. | <ol style="list-style-type: none"> 1. Clean/replace air filter. 2. Replace spark plug. 3. Recharge or replace battery. 4. Replace fuel filter. 5. Empty fuel tank and refill tank with fresh, clean gas. 6. Check all wiring. 7. See "To Adjust Carburetor" in Service Adjustments section. 8. Contact an authorized service center/department. |
| Engine will not turn over | <ol style="list-style-type: none"> 1. Brake pedal not depressed. 2. Attachment clutch is engaged. 3. Weak or dead battery. 4. Blown fuse. 5. Corroded battery terminals. 6. Loose or damaged wiring. 7. Faulty ignition switch. 8. Faulty solenoid or starter. 9. Faulty operator presence switch(es). | <ol style="list-style-type: none"> 1. Depress brake pedal. 2. Disengage attachment clutch. 3. Recharge or replace battery. 4. Replace fuse. 5. Clean battery terminals. 6. Check all wiring. 7. Check/replace ignition switch. 8. Check/replace solenoid or starter. 9. Contact an authorized service center/department. |
| Engine clicks but will not start | <ol style="list-style-type: none"> 1. Weak or dead battery. 2. Corroded battery terminals. 3. Loose or damaged wiring. 4. Faulty solenoid or starter. | <ol style="list-style-type: none"> 1. Recharge or replace battery. 2. Clean battery terminals. 3. Check all wiring. 4. Check/replace solenoid or starter. |
| Loss of power | <ol style="list-style-type: none"> 1. Cutting too much grass/too fast. 2. Throttle in "CHOKE" position. 3. Build-up of grass, leaves, trash under mower. 4. Dirty air filter. 5. Low oil level/dirty oil. 6. Faulty spark plug. 7. Dirty fuel filter. 8. Stale or dirty fuel. 9. Water in fuel. 10. Spark plug wire loose. 11. Dirty engine air screen/fins. 12. Dirty/clogged muffler. 13. Loose or damaged wiring. 14. Carburetor out of adjustment. 15. Engine valves out of adjustment. | <ol style="list-style-type: none"> 1. Raise cutting height/reduce speed. 2. Adjust throttle control. 3. Clean underside of mower housing. 4. Clean/replace air filter. 5. Check oil level/change oil. 6. Clean and regap or change spark plug. 7. Replace fuel filter. 8. Empty fuel tank and refill tank with fresh, clean gas. 9. Empty fuel tank and carburetor, refill tank with fresh gasoline and replace fuel filter. 10. Connect and tighten spark plug wire. 11. Clean engine air screen/fins. 12. Clean/replace muffler. 13. Check all wiring. 14. See "To Adjust Carburetor" in Service Adjustments section. 15. Contact an authorized service center/department. |
| Excessive vibration | <ol style="list-style-type: none"> 1. Worn, bent or loose blade. 2. Bent blade mandrel. 3. Loose/damaged part(s). | <ol style="list-style-type: none"> 1. Replace blade. Tighten blade bolt. 2. Replace blade mandrel. 3. Tighten loose part(s). Replace damaged parts. |

TROUBLESHOOTING

| PROBLEM | CAUSE | CORRECTION |
|---|---|--|
| Engine continues to run when operator leaves seat with attachment clutch engaged | <ol style="list-style-type: none"> 1. Faulty operator-safety presence control system. | <ol style="list-style-type: none"> 1. Check wiring, switches and connections. If not corrected, contact an authorized service center/department. |
| Poor cut - uneven | <ol style="list-style-type: none"> 1. Worn, bent or loose blade. 2. Mower deck not level. 3. Buildup of grass, leaves, trash under mower. 4. Bent blade mandrel. 5. Clogged mower deck vent holes from buildup of grass, leaves, and trash around mandrels. | <ol style="list-style-type: none"> 1. Replace blade. Tighten blade bolt. 2. Level mower deck. 3. Clean underside of mower housing. 4. Replace blade mandrel. 5. Clean around mandrels to open vent holes. |
| Mower blades will not rotate | <ol style="list-style-type: none"> 1. Obstruction in clutch mechanism. 2. Worn/damaged mower drive belt. 3. Frozen idler pulley. 4. Frozen blade mandrel. | <ol style="list-style-type: none"> 1. Remove obstruction. 2. Replace mower drive belt. 3. Replace idler pulley. 4. Replace blade mandrel. |
| Poor grass discharge | <ol style="list-style-type: none"> 1. Engine speed too slow. 2. Travel speed too fast. 3. Wet grass. 4. Mower deck not level. 5. Low/uneven tire air pressure. 6. Worn, bent or loose blade. 7. Buildup of grass, leaves, trash under mower. 8. Mower drive belt worn. 9. Blades improperly installed. 10. Improper blades used. 11. Clogged mower deck vent holes from buildup of grass, leaves, trash around mandrels. | <ol style="list-style-type: none"> 1. Place throttle control in "FAST" position. 2. Shift to slower speed. 3. Allow grass to dry before mowing. 4. Level mower deck. 5. Check tires for proper air pressure. 6. Replace blade. Tighten blade bolt. 7. Clean underside of mower housing. 8. Replace mower drive belt. 9. Reinstall blades sharp edge down. 10. Replace with blades listed in parts manual. 11. Clean around mandrels to open vent holes. |
| Headlight(s) not working (if so equipped) | <ol style="list-style-type: none"> 1. Switch is "OFF". 2. Bulb(s) or lamp(s) burned out. 3. Faulty light switch. 4. Loose or damaged wiring. 5. Blown fuse. | <ol style="list-style-type: none"> 1. Turn switch "ON". 2. Replace bulb(s) or lamp(s). 3. Check/replace light switch. 4. Check wiring and connections. 5. Replace fuse. |
| Battery will not charge | <ol style="list-style-type: none"> 1. Bad battery cell(s). 2. Poor cable connections. 3. Faulty regulator (if so equipped). 4. Faulty alternator. | <ol style="list-style-type: none"> 1. Replace battery. 2. Check/clean all connections. 3. Replace regulator. 4. Replace alternator. |
| Loss of drive | <ol style="list-style-type: none"> 1. Freewheel control in "disengaged" position. 2. Debris on steering plate (if equipped). 3. Motion drive belt worn, damaged, or broken. 4. Air trapped in transmission during shipment or servicing. 5. Axle key missing. | <ol style="list-style-type: none"> 1. Place freewheel control in "engaged" position. 2. See "CLEANING" in the maintenance section. 3. Replace motion drive belt. 4. Purge transmission. 5. Install axle key at rear wheel. See "TO REMOVE WHEEL" in the Service and Adjustments section. |
| Engine "back-fires" when turning engine "OFF" | <ol style="list-style-type: none"> 1. Engine throttle control not set between half and full speed (fast) position before stopping engine. | <ol style="list-style-type: none"> 1. Move throttle control between half and full speed (fast) position before stopping engine. |
| Engine dies when tractor is shifted into reverse | <ol style="list-style-type: none"> 1. Reverse operation system (ROS) is not "ON" while mower or other attachment is engaged. | <ol style="list-style-type: none"> 1. Turn ignition key to ROS "ON" position. See Operation section. |

TRACTOR -- MODEL NUMBER YTH2042 (289610)

DECALS

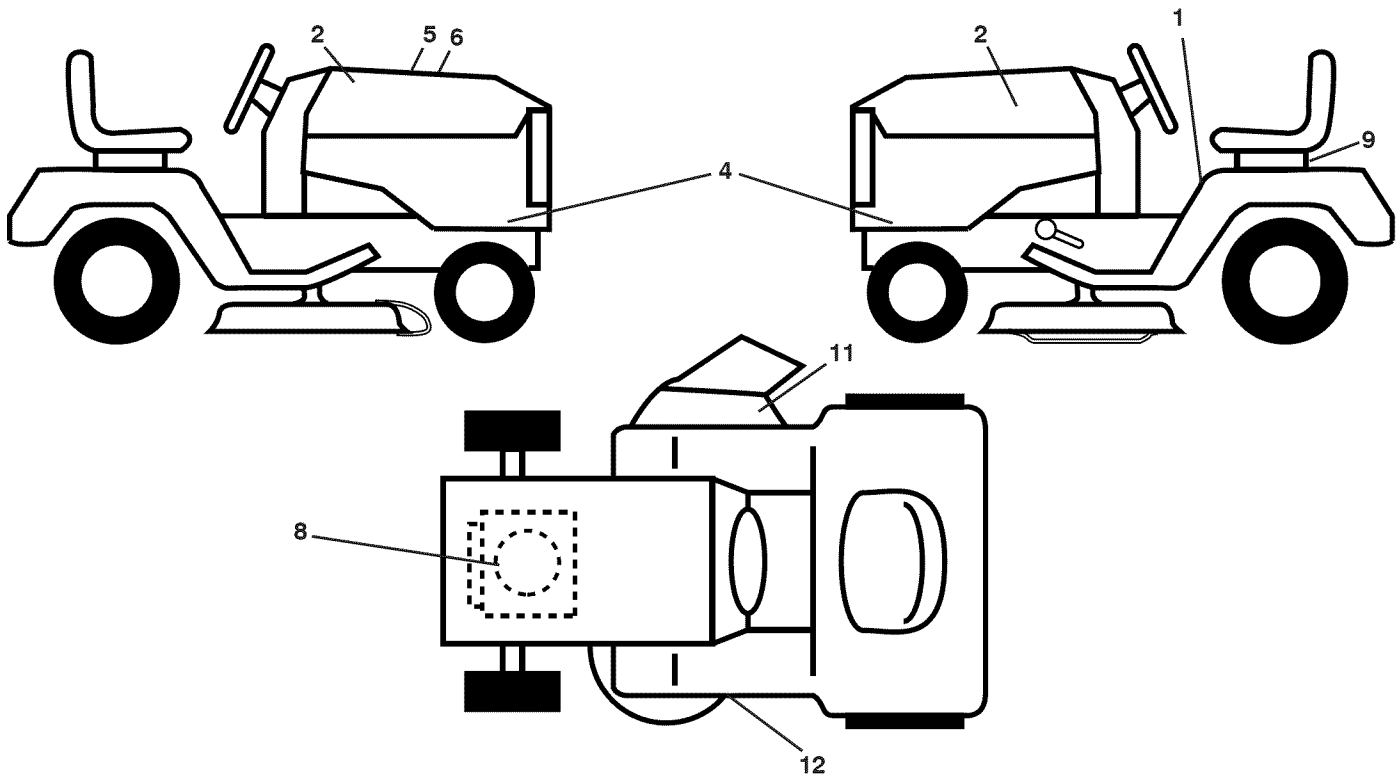

| KEY NO. | PART NO. | DESCRIPTION |
|---------|--------------|----------------------------------|
| 1 | 532 41 16-58 | Decal, Fender Warn./Instructions |
| 2 | 532 42 91-96 | Decal, Hood Logo |
| 4 | 532 41 06-42 | Decal, Hood Panel |
| 5 | 532 42 38-29 | Decal, Customer Respons. |
| 6 | 532 43 65-57 | Decal, Replacement |
| 8 | 532 42 95-51 | Decal, Engine |
| 9 | 532 14 50-05 | Decal, Battery Dnge/Poi |

| KEY NO. | PART NO. | DESCRIPTION |
|---------|--------------|-------------------------------|
| 11 | 532 17 05-63 | Decal, Warning |
| 12 | 532 16 03-96 | Decal, Mower V-Belt Schematic |
| -- | 532 16 69-60 | Decal, Bypass |
| -- | 532 41 08-05 | Pad, Footrest, LH |
| -- | 532 41 10-56 | Pad, Footrest, RH |
| -- | 532 43 65-48 | Manual, Owner's (English) |
| -- | 532 43 65-49 | Manual, Owner's (French) |

WHEELS AND TIRES

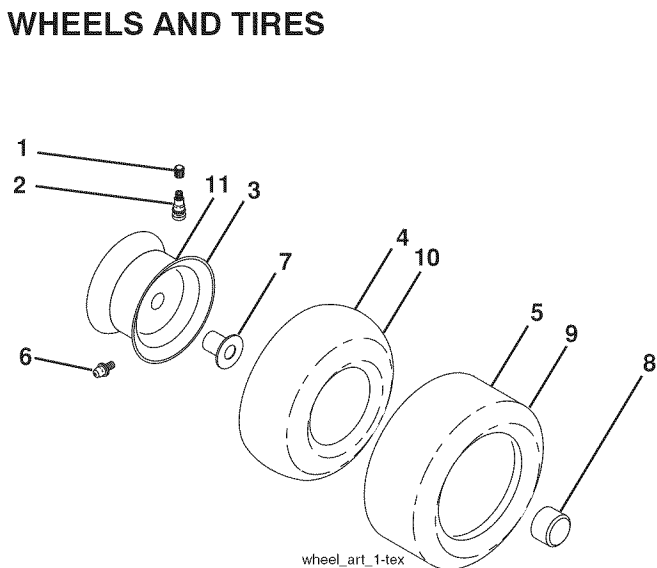

| KEY NO. | PART NO. | DESCRIPTION |
|---------|--------------|--------------------------------------|
| 1 | 532 05 91-92 | Cap Valve Tire |
| 2 | 532 06 51-39 | Stem Valve |
| 3 | 532 13 83-36 | Rim Asm 6" Front |
| 4 | 532 05 99-04 | Tube Front (Service Item Only) |
| 5 | 532 10 62-22 | Tire Front 15 x 6.0-6 |
| 6 | 532 12 49-57 | Fitting Grease (Front Wheel Only) |
| 7 | 532 12 49-59 | Bearing Flange (Front Wheel Only) |
| 8 | 532 17 50-39 | Cap Axle Blk 1 50 x 1 00 |
| 9 | 532 42 05-31 | Tire Rear 18 x 9.5-8 "Turf Saver LT" |
| 10 | 532 12 49-26 | Tube Rear (Service Item Only) |
| 11 | 532 13 83-37 | Rim Asm 8" Rear |
| -- | 532 14 43-34 | Sealant, Tire (10 oz. Tube) |

NOTE: All component dimensions given in U.S. inches
1 inch = 25.4 mm

TRACTOR - - MODEL NUMBER YTH2042 (289610)

SCHEMATIC

SCH11

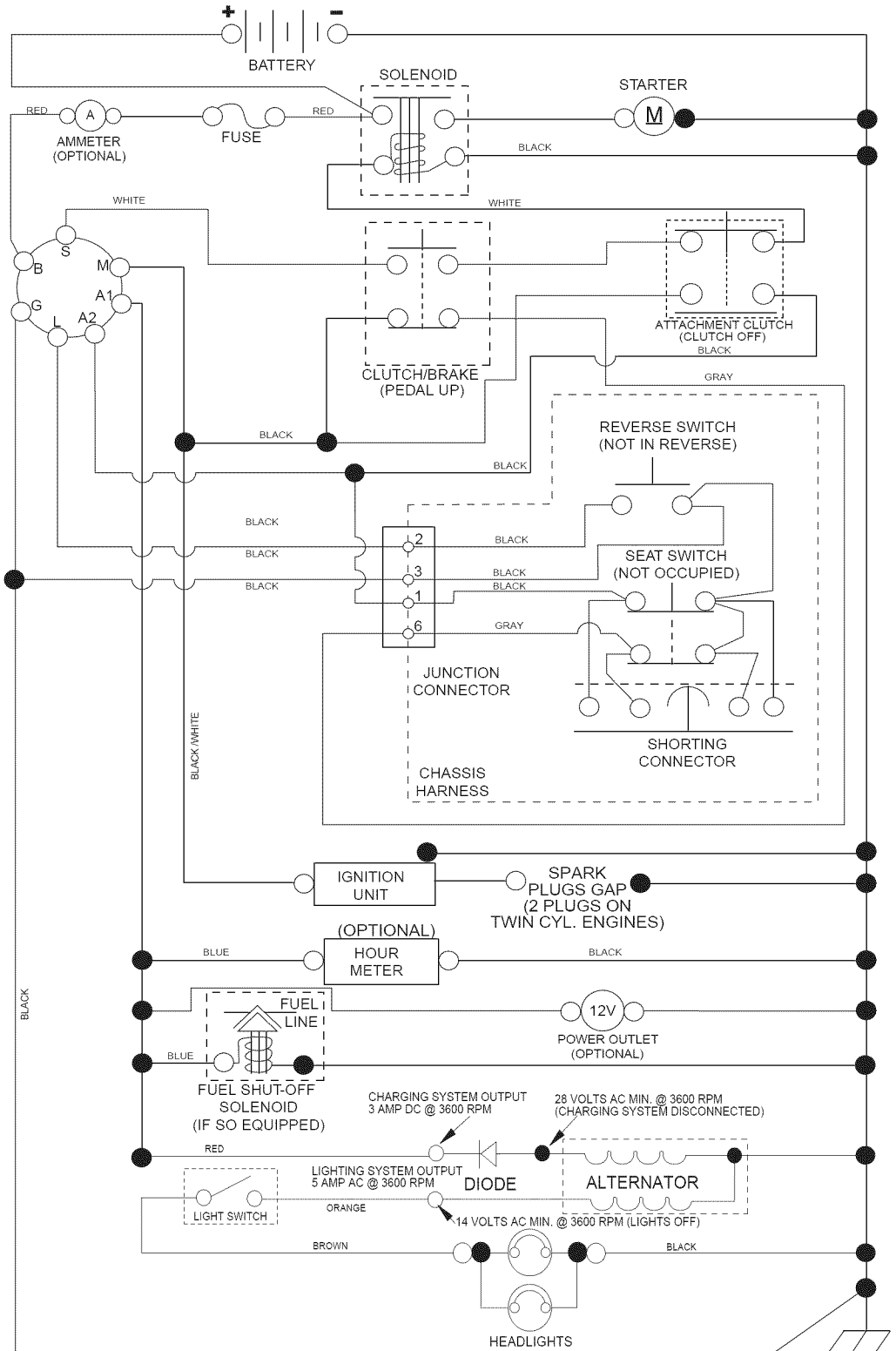

NOTE
YOUR TRACTOR IS EQUIPPED WITH A SPECIAL ALTERNATOR SYSTEM. THE LIGHTS ARE NOT CONNECTED TO THE BATTERY, BUT HAVE THEIR OWN ELECTRICAL SOURCE. BECAUSE OF THIS, THE BRIGHTNESS OF THE LIGHTS WILL CHANGE WITH ENGINE SPEED. AT IDLE THE LIGHTS WILL DIM. AS THE ENGINE IS SPEEDED UP, THE LIGHTS WILL BECOME THEIR BRIGHTEST.

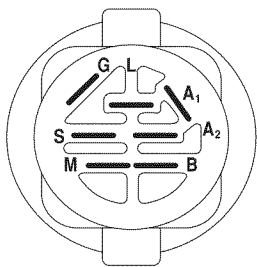

IGNITION SWITCH

| POSITION | CIRCUIT | "MAKE" |
|--------------|------------|--------|
| OFF | M+G+A1 | |
| RUN/OVERRIDE | B+A1 | |
| RUN | B+A1 | L+A2 |
| START | B + S + A1 | |

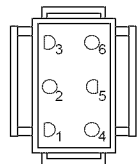

CHASSIS HARNESS CONNECTOR (MATING SIDE)

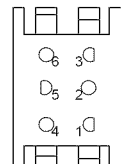

DASH HARNESS CONNECTOR (MATING SIDE)

WIRING INSULATED CLIPS
NOTE: IF WIRING INSULATED CLIPS WERE REMOVED FOR SERVICING OF UNIT, THEY SHOULD BE RE-INSTALLED TO PROPERLY SECURE YOUR WIRING.

NON-REMOVABLE CONNECTIONS

REMOVABLE CONNECTIONS

TRACTOR -- MODEL NUMBER YTH2042 (289610)

ELECTRICAL

T02S

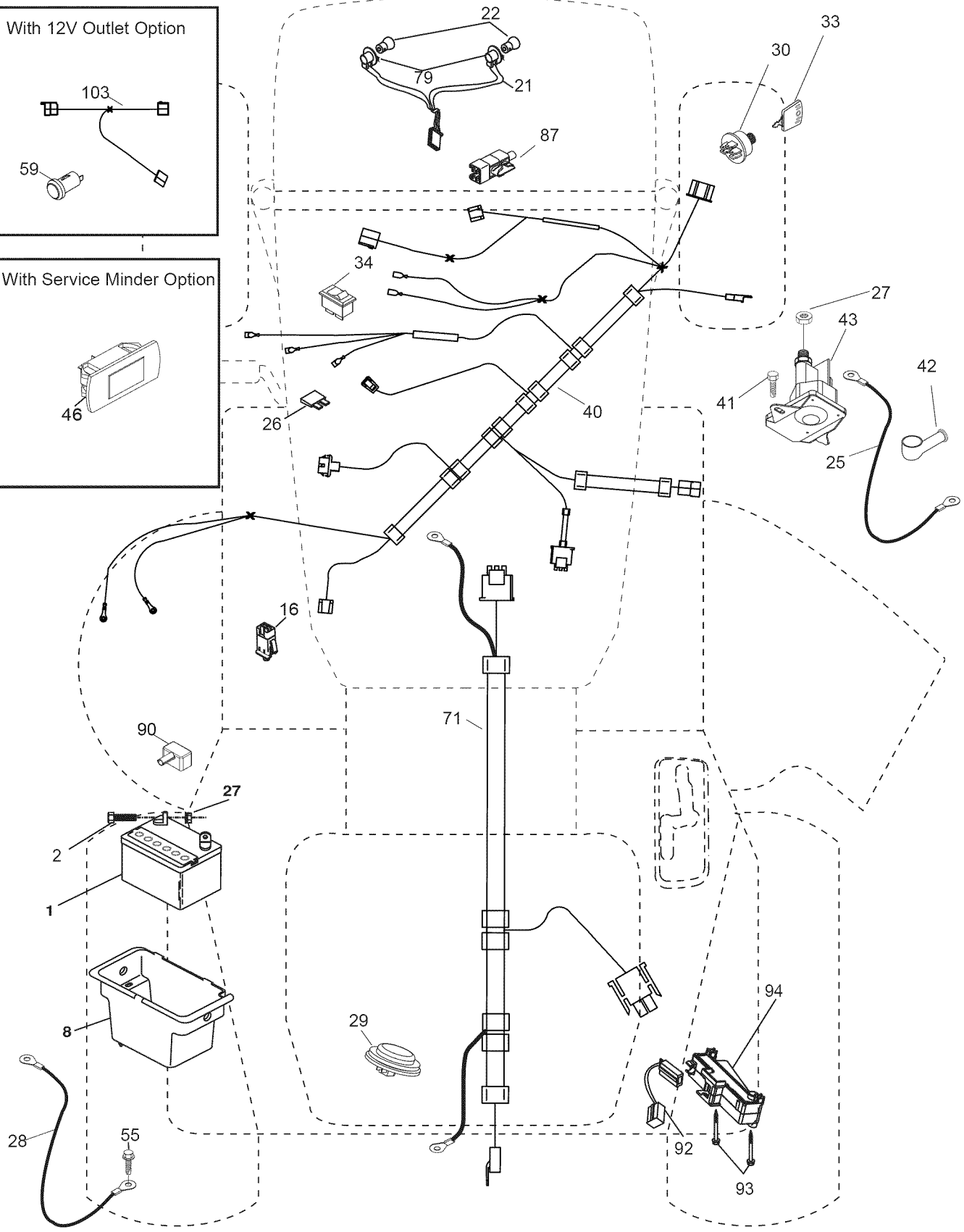
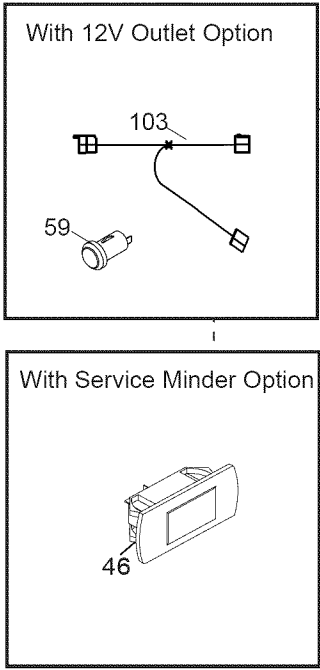

TRACTOR -- MODEL NUMBER YTH2042 (289610)

ELECTRICAL

| KEY NO. | PART NO. | DESCRIPTION |
|---------|--------------|--------------------------------|
| 1 | 532 16 34-65 | Battery |
| 2 | 874 76 04-12 | Bolt Hex Head 1/4-20 x 3/4 |
| 8 | 532 19 32-28 | Box Battery |
| 16 | 532 17 61-38 | Switch Interlock Push-In |
| 21 | 532 40 02-52 | Harness Socket Light w/4152J |
| 22 | 532 00 41-52 | Bulb Light |
| 25 | 532 41 28-95 | Cable Starter |
| 26 | 532 17 51-58 | Fuse |
| 27 | 873 51 04-00 | Nut Keps Hex 1/4-20 unc |
| 28 | 532 19 88-85 | Cable, Ground |
| 29 | 532 40 15-45 | Switch, Seat |
| 30 | 532 19 33-50 | Switch, Ign |
| 33 | 532 41 19-35 | Key/Chain |
| 34 | 532 11 07-12 | Switch Light/Reset |
| 40 | 532 40 10-98 | Harness Ign. Dash |
| 41 | 817 72 04-08 | Screw Thd Cut 1/4-20 x 1/2 |
| 42 | 532 13 15-63 | Cover, Terminal |
| 43 | 532 19 25-07 | Solenoid |
| 55 | 817 06 05-12 | Screw Thdrol 5/16-18 x 3/4 |
| 71 | 532 40 04-49 | Harness Chassis |
| 79 | 532 17 52-42 | Socket Asm Bulb Twistlock |
| 87 | 532 19 78-02 | Switch Interlock Clutch Cable |
| 90 | 532 40 07-25 | Cover, Terminal Battery |
| 92 | 532 19 66-15 | Harness Pigtail Reverse Switch |
| 93 | 532 19 25-40 | Screw Plastite 10-14 x 2.0 |
| 94 | 532 19 18-34 | Module Reverse ROS |

NOTE: All component dimensions given in U.S. inches
1 inch = 25.4 mm

TRACTOR - - MODEL NUMBER YTH2042 (289610)

CHASSIS

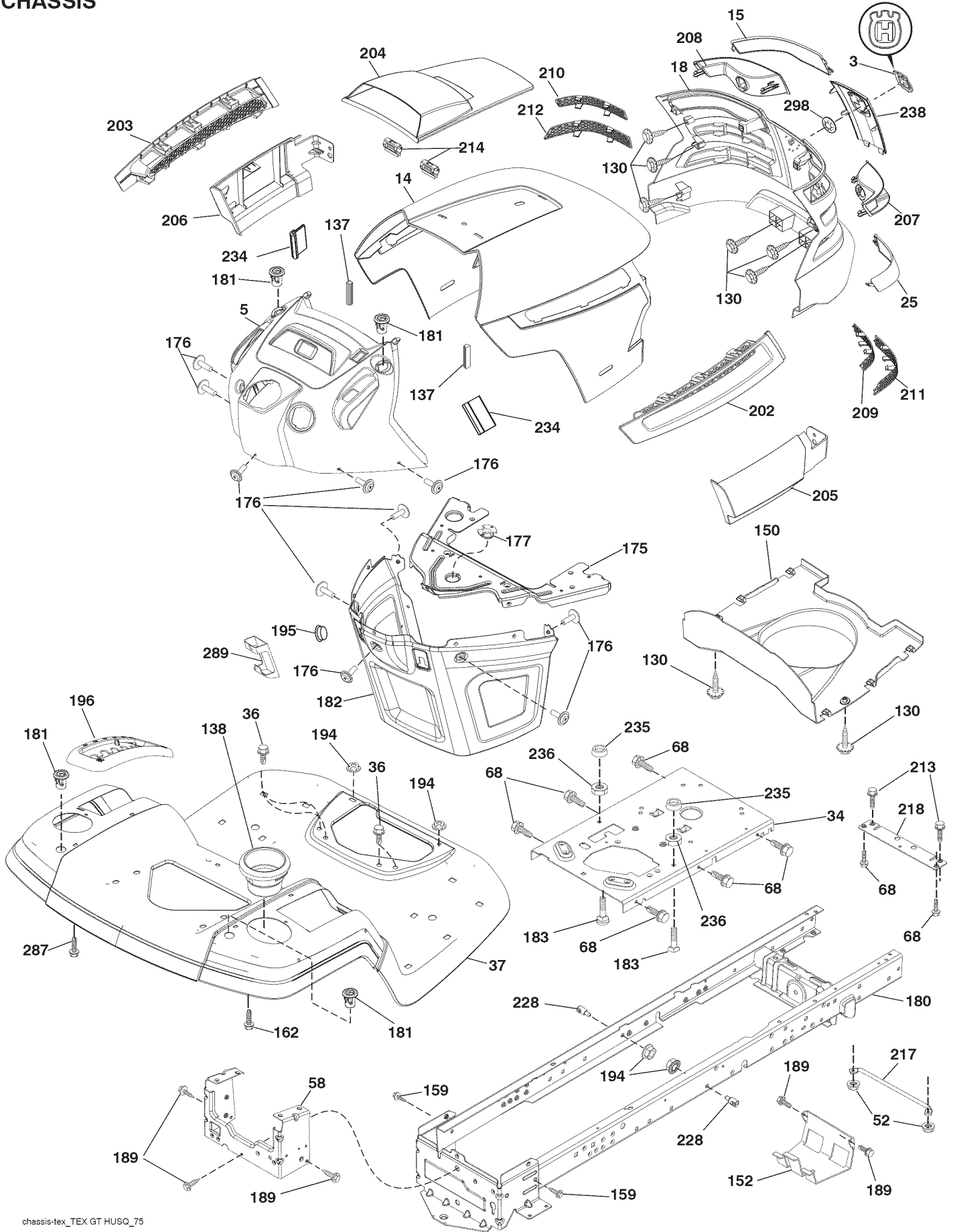

TRACTOR - - MODEL NUMBER YTH2042 (289610)

CHASSIS

| KEY NO. | PART NO. | DESCRIPTION | KEY NO. | PART NO. | DESCRIPTION |
|---------|--------------|---------------------------------|---------|--------------|---------------------------------|
| 3 | 532 43 07-71 | Logo | 195 | 532 40 41-37 | Plug Dash |
| 5 | 532 40 87-04 | Dash | 196 | 532 41 45-80 | Console Asm. Deck Lift |
| 14 | 532 41 10-46 | Hood | 202 | 532 40 30-48 | Vent Side Hood RH |
| 15 | 532 19 89-07 | Lens LH | 203 | 532 40 30-76 | Vent Side Hood LH |
| 18 | 532 40 86-07 | Grille | 204 | 532 41 66-13 | Vent Top Hood |
| 25 | 532 19 89-06 | Lens RH | 205 | 532 40 17-09 | Skirt Side RH |
| 34 | 532 19 61-25 | Plate Engine | 206 | 532 40 17-11 | Skirt Side LH |
| 36 | 817 06 05-12 | Screw 5/16-18 x 3/4 | 207 | 532 19 71-98 | Bezel RH |
| 37 | 532 41 63-07 | Fender | 208 | 532 19 71-99 | Bezel LH |
| 52 | 873 68 05-00 | Nut Crown Lock 5/16 | 209 | 532 19 91-30 | Insert Hex Top RH |
| 58 | 532 41 22-80 | Drawbar Upper | 210 | 532 19 91-31 | Insert Hex Top LH |
| 68 | 817 49 05-08 | Screw THDROL 5/16-18 x 1/2 | 211 | 532 19 91-32 | Insert Hex Bottom RH |
| 130 | 532 41 63-58 | Screw #10 x 0.750 BOS Thread | 212 | 532 19 91-33 | Insert Hex Bottom LH |
| 137 | 532 40 75-90 | Bumper Dash | 213 | 874 76 05-12 | Bolt 5/16-18 x 3/4 |
| 138 | 532 40 29-54 | Cupholder | 214 | 532 19 91-45 | Clip Retainer |
| 150 | 532 19 85-14 | Air Duct | 217 | 532 40 91-67 | Rod Pivot Hood |
| 152 | 532 19 95-35 | Shield Browning | 218 | 532 19 63-95 | X-Piece Hood Stop |
| 159 | 817 00 06-12 | Screw Hexwash Thor 3/8-16 x 3/4 | 228 | 532 19 51-61 | Stud Fastener |
| 162 | 532 14 24-32 | Screw | 234 | 532 40 47-42 | Bumper Hood |
| 175 | 532 19 63-04 | Crossmember Plate | 235 | 532 40 61-29 | Spacer Fender |
| 176 | 532 40 07-76 | Screw 10-24 x 5/8 | 236 | 873 93 05-00 | Nut Lock 5/16-18 unc |
| 177 | 532 19 52-27 | Bushing Steering | 238 | 532 40 86-06 | Trim |
| 180 | 532 41 50-63 | Chassis | 287 | 817 60 04-06 | Screw Hex Washhead 1/4-20 x 3/8 |
| 181 | 532 40 30-25 | Bushing Mtg. Fender Crgo | 289 | 532 40 35-71 | Plug Cruise/Phone |
| 182 | 532 40 68-59 | Dash Lower | 298 | 532 11 04-52 | Nut Push |
| 183 | 874 52 05-20 | Bolt 5/16-18 x 1-1/4 Full Thd | | | |
| 189 | 817 00 05-12 | Screw 5/16-18 x 3/4 | | | |
| 194 | 873 90 05-00 | Nut Lock Hex Flange 5/16-18 | | | |

NOTE: All component dimensions given in U.S. inches
1 inch = 25.4 mm

TRACTOR - - MODEL NUMBER YTH2042 (289610)

DRIVE

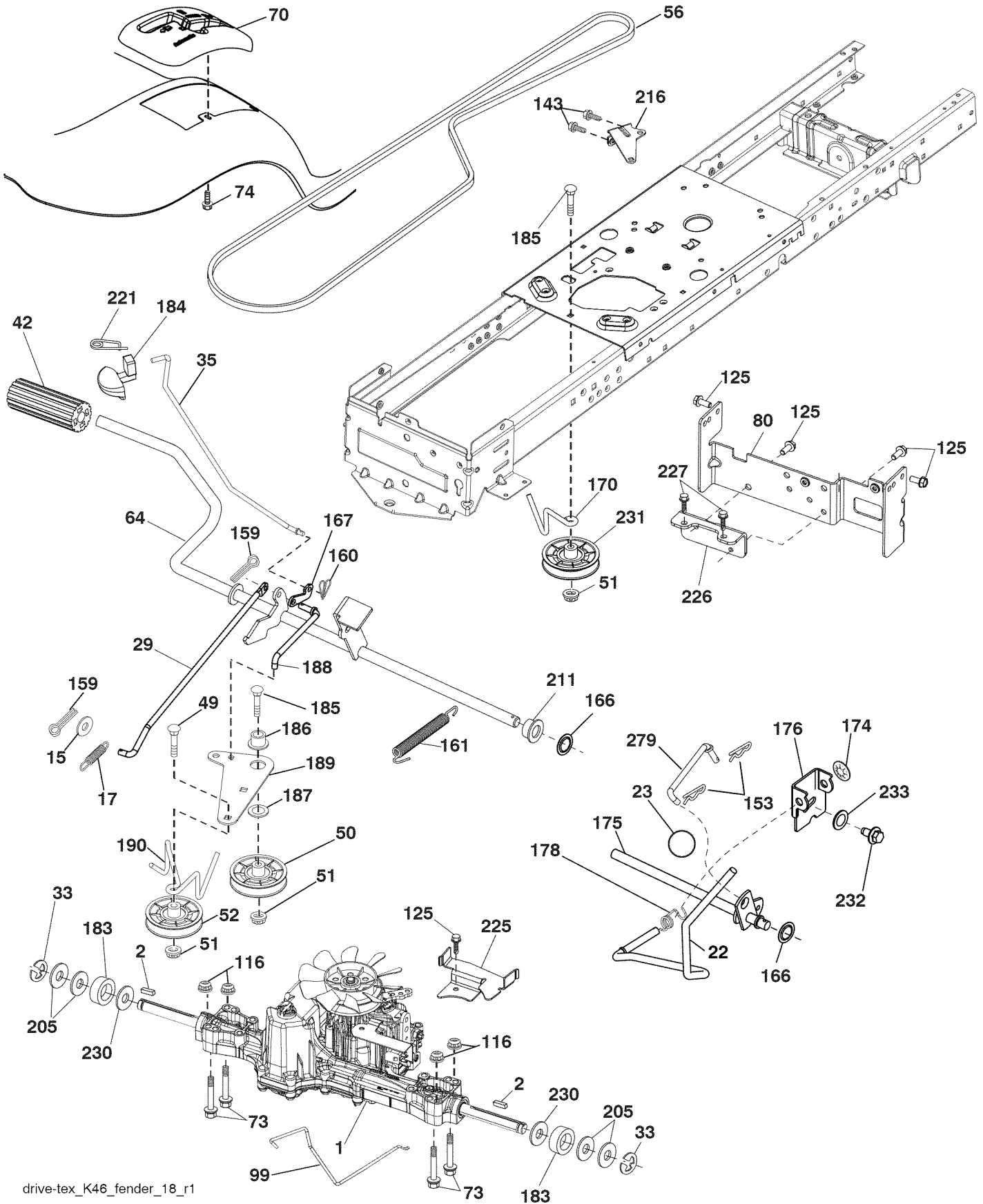

drive-tex_K46_fender_18_r1

TRACTOR - - MODEL NUMBER YTH2042 (289610)

DRIVE

| KEY NO. | PART NO. | DESCRIPTION | KEY NO. | PART NO. | DESCRIPTION |
|---------|--------------|---|---------|--------------|----------------------------------|
| 1 | --- | Transaxle, Tufftorq K46BA (Internal Parts Not Available) | 167 | 532 40 52-57 | Latch Brake Parking |
| 2 | 532 12 35-83 | Key Square | 170 | 532 41 34-30 | Keeper Belt Centerspan |
| 15 | 819 13 13-16 | Washer 13/32 x 13/16 x 16 Ga. | 174 | 532 19 72-89 | Nut Push |
| 17 | 532 41 36-78 | Spring, Brake | 175 | 532 40 85-39 | Shaft Asm Shift |
| 22 | 532 19 76-60 | Rod Shift | 176 | 532 19 62-14 | Arm Clevis Rod Shift |
| 23 | 532 14 08-45 | Knob | 178 | 532 19 74-56 | Spring Shift |
| 29 | 532 40 38-06 | Rod, Brake | 183 | 532 13 70-57 | Spacer Axle |
| 33 | 812 00 00-01 | Ring E | 184 | 532 40 31-18 | Handle Parking Brake |
| 35 | 532 19 95-91 | Rod, Brake, Park | 185 | 872 11 06-22 | Bolt |
| 42 | 532 12 48-72 | Cover, Foot Pedal | 186 | 532 19 43-21 | Spacer Retainer |
| 49 | 872 11 06-14 | Bolt | 187 | 819 13 32-10 | Washer |
| 50 | 532 19 43-27 | Pulley Idler Flat | 188 | 532 19 43-23 | Link Clutch Ground Drive |
| 51 | 873 90 06-00 | Lock Nut 3/8-16 | 189 | 532 19 43-17 | Bellcrank Ground Drive |
| 52 | 532 19 43-26 | Idler V-Groove 910" Offset | 190 | 532 19 43-18 | Keeper Bellcrank Ground Drive |
| 56 | 532 13 09-69 | V-Belt, Drive | 205 | 532 12 17-48 | Washer 25/32 x 1-5/8 x 16 Ga. |
| 64 | 532 19 62-00 | Shaft Asm. Pedal Brake Control | 211 | 532 19 62-12 | Bushing Shaft |
| 70 | 532 41 14-74 | Console | 216 | 532 19 61-31 | Bracket Pulley Idler |
| 73 | 874 49 05-40 | Bolt Hex 5/16-18 Gr. 5 | 221 | 532 40 31-87 | Retainer Spring Clip Handle |
| 74 | 532 14 24-32 | Screw 1/4 x 1/2 | 225 | 532 40 33-19 | Keeper Belt Transaxle |
| 80 | 532 41 00-24 | Strap Torque | 226 | 532 40 15-64 | Bracket Mount Torque |
| 99 | 532 41 57-42 | Rod Spring Bypass | 227 | 817 49 05-12 | Screw 5/16-18 x 3/4 |
| 116 | 873 90 05-00 | Nut Lock Hex Flange 5/16-18 | 230 | 532 18 89-67 | Washer Harden .793 x 1.637 x 060 |
| 125 | 817 00 05-12 | Screw 5/16-18 x 3/4 | 231 | 532 40 72-87 | Idler V-Groove 1.688" Offset |
| 143 | 817 49 05-08 | Screw THDROL 5/16-18 | 232 | 874 78 07-16 | Bolt 7/16-14 x 1 Gr 5 |
| 153 | 532 12 47-88 | Retainer Spring 1" | 233 | 532 40 52-96 | Washer Serrated |
| 159 | 876 02 04-12 | Pin Cotter 1/8 x 3/4 | 279 | 532 41 31-50 | Link Shift |
| 160 | 532 16 94-84 | Retainer Clip | | | |
| 161 | 532 10 57-09 | Spring, Return, Clutch | | | |
| 166 | 532 42 91-64 | Nut Push .625 | | | |

NOTE: All component dimensions given in U.S. inches
1 inch = 25.4 mm

TRACTOR - - MODEL NUMBER YTH2042 (289610)

ENGINE

| KEY NO. | PART NO. | DESCRIPTION |
|---------|--------------|--|
| 1 | - - - - - | Engine Briggs Model No. 331777-1372-B1 |
| 2 | 532 18 86-55 | Muffler |
| 9 | 532 19 43-20 | Keeper Belt Engine |
| 12 | 532 40 54-71 | Pulley Engine |
| 15 | 532 40 74-89 | Tank Fuel |
| 18 | 532 43 02-20 | Cap Asm |
| 20 | 532 40 15-08 | Control Throttle |
| 21 | 532 41 63-58 | Screw #10 x 0.750 BOS Thread |
| 28 | 532 40 11-37 | Fuel Line |
| 29 | 532 13 71-80 | Spark Arrester Kit |
| 37 | 532 12 34-87 | Clamp Hose |
| 42 | 810 04 07-00 | Washer Lock 7/16 |
| 45 | 873 51 04-00 | Nut Keps Hex 1/4-20 unc |
| 69 | 532 16 52-91 | Gasket |
| 79 | 532 19 23-34 | Screw 5/16-18 x 3/4 |
| 81 | 532 14 84-56 | Tube Drain Oil Easy |
| 82 | 532 42 82-87 | Valve Drain Oil |
| 84 | 817 06 06-20 | Screw 3/8-16 x 1/4 |
| 85 | 532 17 39-37 | Bolt Hex 7/16-20 x 4 Gr. 5 |
| 87 | 532 17 18-77 | Bolt 5/16-18 unc x 3/4 w/sems |
| 90 | 817 00 06-16 | Screw 3/8-16 x 1 |
| 94 | 532 40 54-50 | Exhaust Tube |
| 96 | 819 09 14-16 | Washer 9/32 x 7/8 x 16 Ga. |
| 97 | 817 67 04-12 | Screw 1/4-20 x 3/4 |

NOTE: All component dimensions given in U.S. inches
1 inch = 25.4 mm

For engine service and replacement parts, call the toll free number for your engine manufacturer listed below:

Briggs & Stratton 1-800-233-3723

Engine Power Rating Information

The gross power rating for individual gas engine models is labeled in accordance with SAE (Society of Automotive Engineers) code J1940 (Small Engine Power & Torque Rating Procedure), and rating performance has been obtained and corrected in accordance with SAE J1995 (Revision 2002-05). Torque values are derived at 3060 RPM; horsepower values are derived at 3600 RPM. Actual gross engine power will be lower and is affected by, among other things, ambient operating conditions and engine-to-engine variability. Given both the wide array of products on which engines are placed and the variety of environmental issues applicable to operating the equipment, the gas engine will not develop the rated gross power when used in a given piece of power equipment (actual "on-site" or net power). This difference is due to a variety of factors including, but not limited to, accessories (air cleaner, exhaust, charging, cooling, carburetor, fuel pump, etc.), application limitations, ambient operating conditions (temperature, humidity, altitude), and engine-to-engine variability. Due to manufacturing and capacity limitations, Briggs & Stratton may substitute an engine of higher rated power for this Series engine.

TRACTOR - - MODEL NUMBER YTH2042 (289610)

STEERING ASSEMBLY

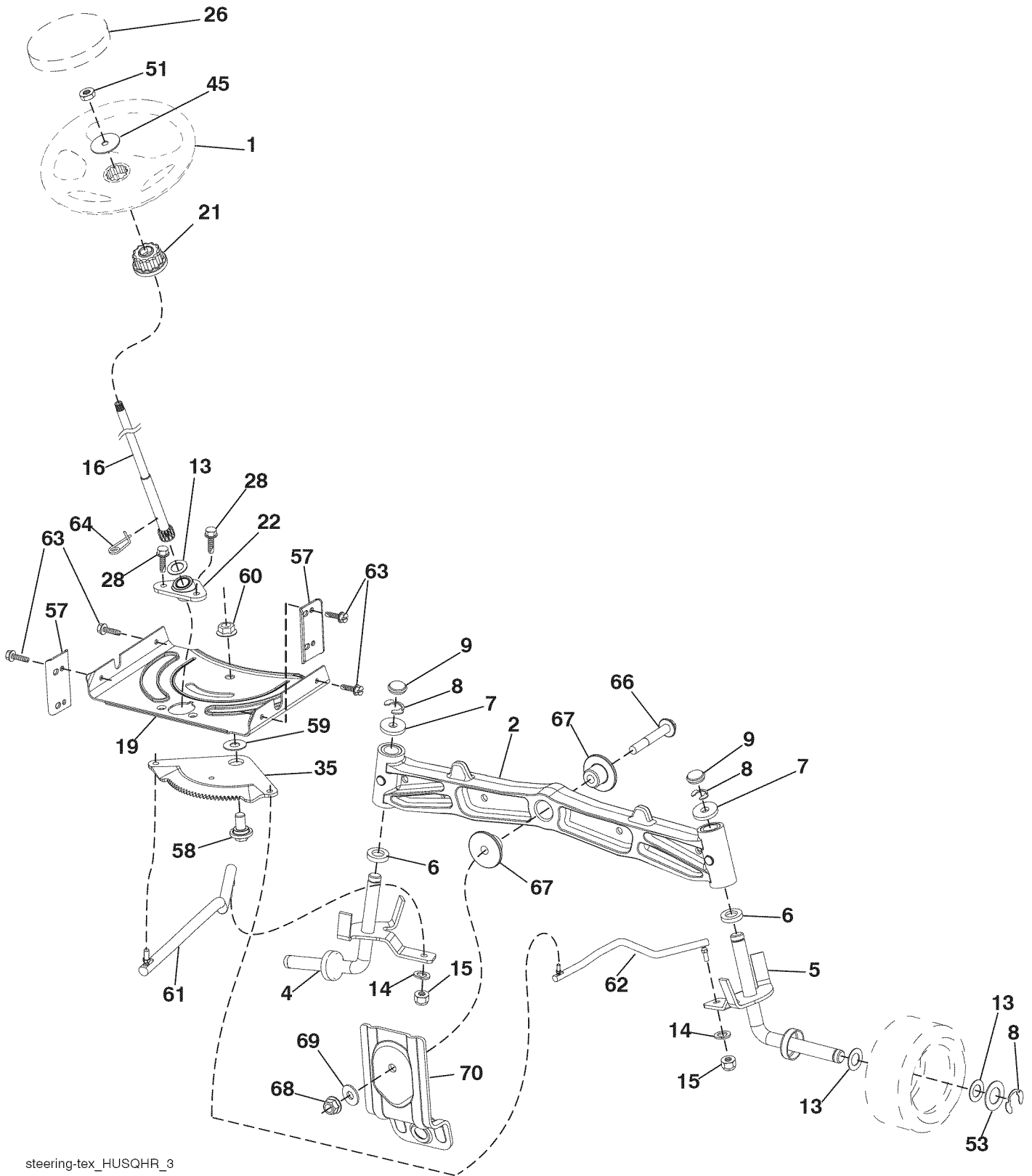

steering-tex_HUSQHR_3

TRACTOR -- MODEL NUMBER YTH2042 (289610)

STEERING ASSEMBLY

| KEY NO. | PART NO. | DESCRIPTION |
|---------|--------------|-------------------------------------|
| 1 | 532 42 34-69 | Wheel, Steering |
| 2 | 532 19 59-68 | Axle Asm., Front |
| 4 | 532 40 30-87 | Spindle Asm., LH |
| 5 | 532 40 30-88 | Spindle Asm., RH |
| 6 | 532 12 49-31 | Bearing, Race Thrust Harden |
| 7 | 532 12 17-48 | Washer 25/32 x 1-5/8 x 16 Ga. |
| 8 | 812 00 00-29 | Ring, Klip #T5304-75 |
| 9 | 532 12 12-32 | Cap, Spindle |
| 13 | 532 12 17-49 | Washer 25/32 x 1-1/4 x 16 Ga. |
| 14 | 810 04 06-00 | Washer, Lock Hvy Hlcl Spr 3/8 |
| 15 | 873 54 06-00 | Nut, Crown Lock 3/8-24 unf |
| 16 | 532 40 82-19 | Shaft Steering |
| 19 | 532 19 47-29 | Plate Steering |
| 21 | 532 18 67-37 | Adapter, Wheel Steering |
| 22 | 532 42 05-37 | Strg. Supt. Lower |
| 26 | 532 41 59-87 | Insert, Wheel Steering |
| 28 | 817 00 06-12 | Screw 3/8-16 x 3/4 |
| 35 | 532 19 47-32 | Gear, Sector Plate |
| 45 | 819 18 38-12 | Washer 9/16 ID x 2-3/8 OD 12 GZIN |
| 51 | 873 94 08-00 | Nut Hex Jam Toplock 1/2-20 |
| 53 | 532 18 89-67 | Washer Hardened .793 x 1.637 x .060 |
| 57 | 532 40 74-65 | Bracket Upstop |
| 58 | 532 19 47-47 | Bolt Shoulder Sector Pivot CFM |
| 59 | 532 19 47-48 | Washer Thrust Sector Steering |
| 60 | 873 97 10-00 | Nut Flange Lock 5/8-11 |
| 61 | 532 19 47-40 | Draglink, LH |
| 62 | 532 19 47-41 | Draglink, RH |
| 63 | 817 00 05-12 | Screw 5/16-18 x 3/4 |
| 64 | 532 19 98-49 | Retainer Clip Spring Steering |
| 66 | 871 02 07-48 | Bolt Hex Fghd 7/16-14 x 3 Serr |
| 67 | 532 19 47-37 | Bushing PM Front Axle |
| 68 | 873 90 07-00 | Nut Lock Flange 7/16-14 Gr. 5 |
| 69 | 532 19 91-62 | Washer 1.5 x .505 x .118 |
| 70 | 532 19 61-97 | Bracket Deck Susp. Front |

NOTE: All component dimensions given in U.S. inches
1 inch = 25.4 mm

TRACTOR - - MODEL NUMBER YTH2042 (289610)

MOWER DECK

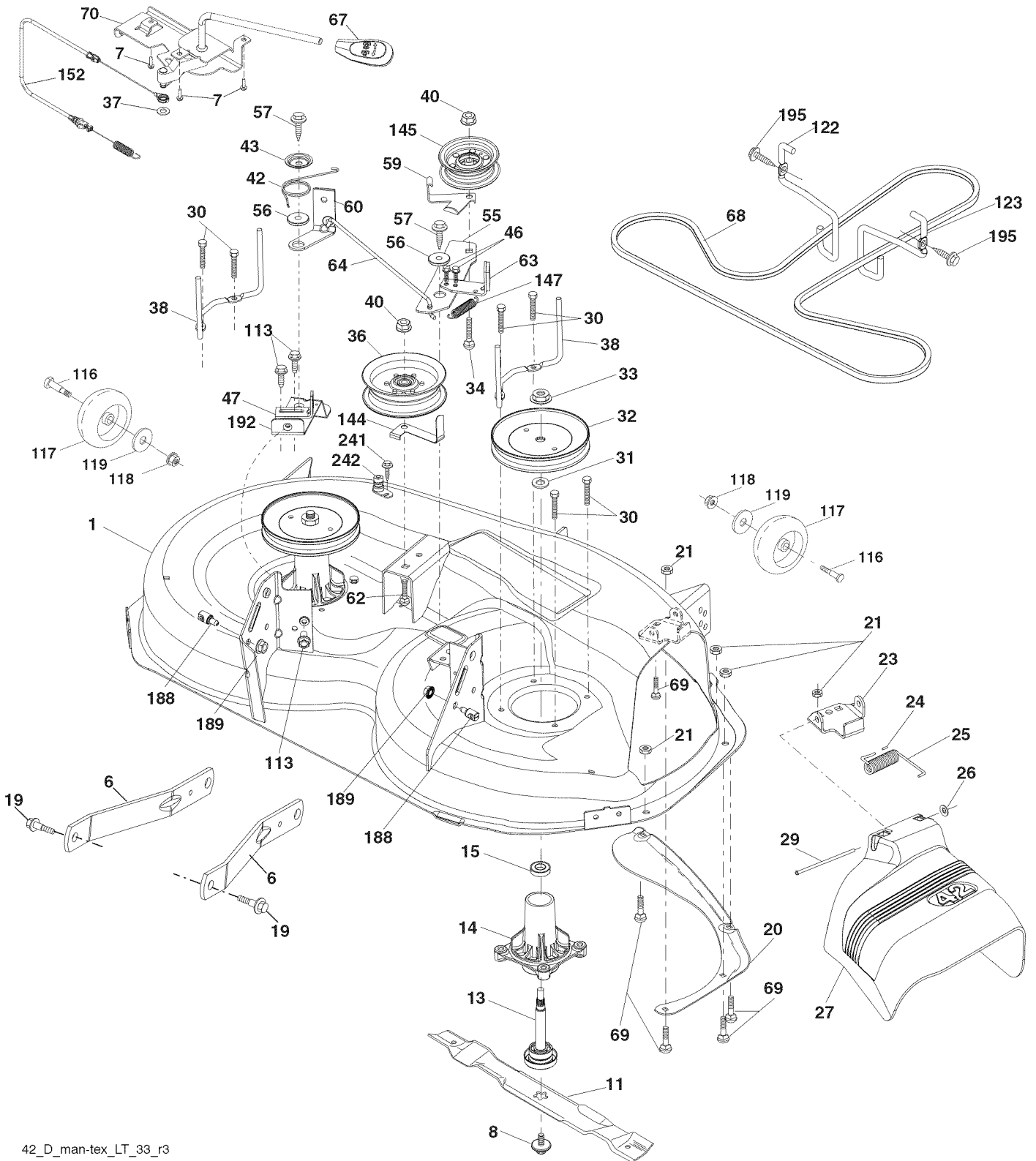

42_D_man-tex_LT_33_r3

TRACTOR -- MODEL NUMBER YTH2042 (289610)

MOWER DECK

| KEY NO. | PART NO. | DESCRIPTION | KEY NO. | PART NO. | DESCRIPTION |
|------------|--------------|--|------------|--------------|--|
| 1 | 532 40 29-99 | Mower Housing | 56 | 532 19 90-92 | Spacer, Retainer |
| 6 | 532 19 51-86 | Arm Suspension | 57 | 817 00 06-16 | Screw 3/8-16 x 1 |
| 7 | 532 41 63-58 | Screw #10 x .750 BOS Thread | 59 | 532 14 10-43 | Guard, Tuv Idler |
| 8 | 532 19 30-03 | Bolt/Washer Asm 7/16-20 unf | 60 | 532 19 72-61 | Arm Brake Mower |
| 11 | 532 13 89-71 | Blade, 42" Hi-Lift (For bagging or discharge) | 62 | 872 11 06-16 | Bolt Rd Hd Sq Nk 3/8-16 unc x 2 |
| -- | 532 13 41-49 | Blade, 42" Mulching Std (For mulching mowers only) | 63 | 532 19 94-77 | Arm Brake Mower |
| -- | 532 13 97-75 | Blade, 42" Mulching Premium (For better wear when mulching) | 64 | 532 19 99-18 | Link Brake |
| -- | 532 42 47-52 | Blade 42SP" 3N1 | 67 | 532 40 30-12 | Handle Clutch Cable |
| -- | 532 42 27-19 | Blade 42SP" 3N1 Premium | 68 | 532 42 96-36 | V-Belt |
| 13 | 532 19 28-72 | Shaft Assembly, Mandrel | 69 | 872 14 05-05 | Bolt |
| 14 | 532 18 72-81 | Housing, Mandrel | 70 | 532 40 65-63 | Clutch Asm Manual |
| 15 | 532 11 04-85 | Bearing, Ball, Mandrel | 113 | 817 00 05-10 | Screw 5/16-18 |
| 19 | 532 19 65-39 | Bolt, Shoulder | 116 | 532 12 48-42 | Bolt, Shoulder |
| 20 | 532 15 97-70 | Baffle, Vortex | 117 | 532 18 86-06 | Wheel, Gauge |
| 21 | 873 68 05-00 | Nut, Crownlock 5/16-18 unc | 118 | 873 93 06-00 | Nut, Crownlock 3/8-1 |
| 23 | 532 19 25-57 | Bracket, Deflector | 119 | 819 12 14-14 | Washer 13/32 x 7/8 x 14 Ga. |
| 24 | 532 10 53-04 | Cap, Sleeve | 122 | 532 19 72-58 | Keeper Belt Engine LH |
| 25 | 532 19 70-26 | Spring, Torsion, Deflector | 123 | 532 19 72-59 | Keeper Belt Engine RH |
| 26 | 532 11 04-52 | Nut, Push | 144 | 532 19 92-04 | Keeper Belt |
| 27 | 532 40 30-04 | Shield, Deflector | 145 | 532 19 31-97 | Pulley Idler |
| 29 | 532 13 14-91 | Rod, Hinge | 147 | 532 40 19-71 | Spring Return |
| 30 | 532 17 39-84 | Screw Thdrol Rolling Wsh Hd | 152 | 532 43 51-10 | Manual Clutch Cable |
| 31 | 532 18 76-90 | Washer, Spacer | 188 | 532 19 51-61 | Stud Fastener |
| 32 | 532 19 74-73 | Pulley, Mandrel | 189 | 873 90 05-00 | Nut Lock Hex Flange |
| 33 | 532 40 02-34 | Nut, Toplock, Flanged | 192 | 532 19 72-60 | Bracket Brake Stand LH |
| 34 | 872 11 06-12 | Bolt Carr Sh. 3/8-16 x 1-1/2 Gr. 5 | 195 | 817 00 06-12 | Screw 3/8-16 x 3/4 |
| 36 | 532 19 73-79 | Pulley, Idler, Flat | 241 | 532 15 29-27 | Screw TT #10-32 5 3/8 Flange |
| 37 | 819 13 13-16 | Washer | 242 | 532 41 55-98 | Port Washout |
| 38 | 532 43 25-20 | Keeper Belt LH Mandrel | -- | 532 41 64-05 | Coupling Quick connect |
| 40 | 873 90 06-00 | Nut, Lock Flg. 3/8-16 unc | -- | 532 19 28-70 | Mandrel Assembly (Includes hous- ing, shaft assembly, and bearing only - pulley/nut/washer and blade bolt/washers not included) |
| 42 | 532 19 84-10 | Spring Torsion Brake | -- | 532 43 29-37 | Replacement Mower, Complete |
| 43 | 532 19 72-56 | Spring Torsion Retainer | | | |
| 46 | 532 13 77-29 | Screw Thd Roll 1/4-20 x 5/8 | | | |
| 47 | 532 19 72-50 | Bracket Clutch Cable | | | |
| 55 | 532 19 72-49 | Arm, Idler | | | |

NOTE: All component dimensions given in U.S. inches
1 inch = 25.4 mm

TRACTOR - - MODEL NUMBER YTH2042 (289610)

MOWER LIFT

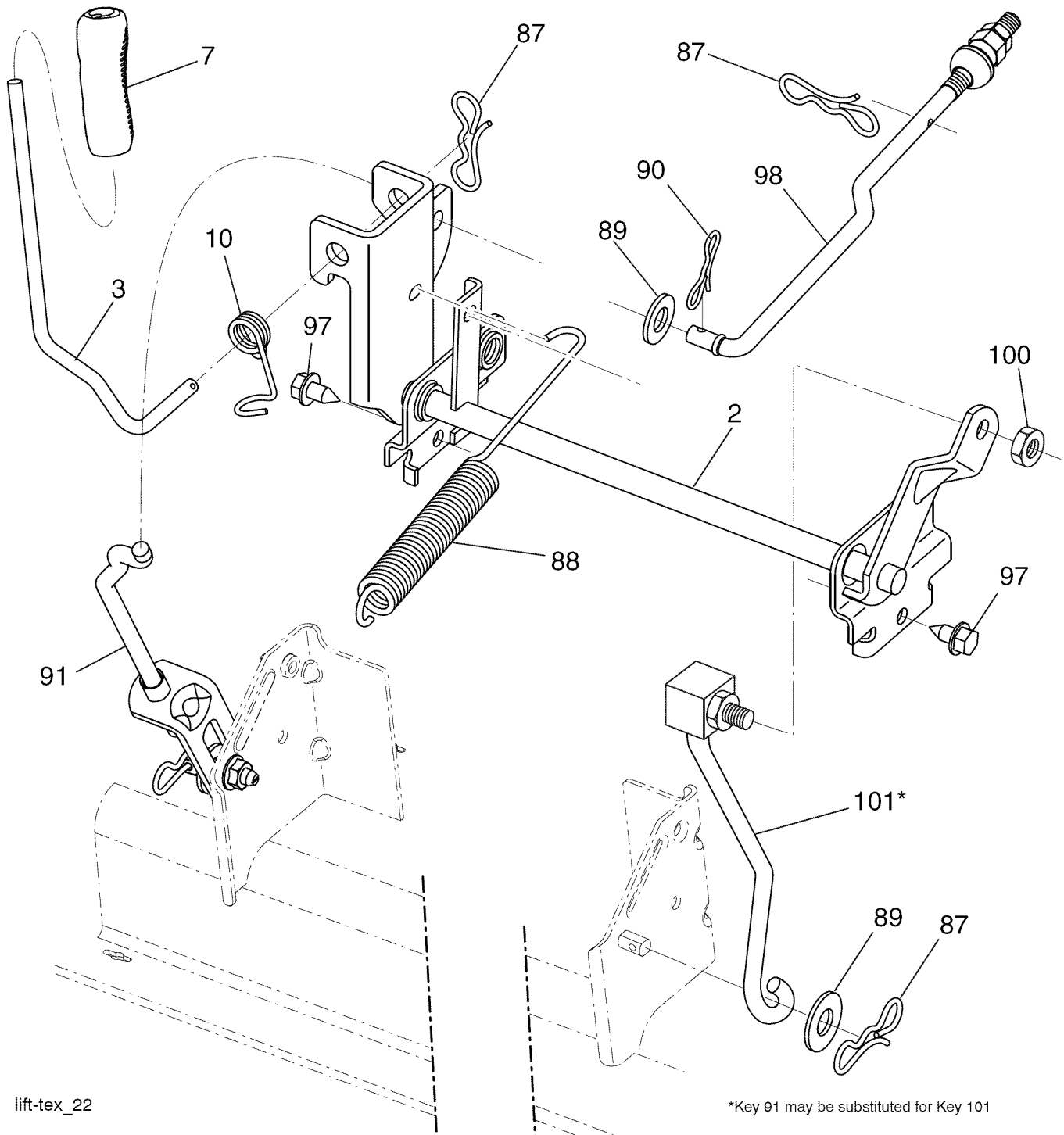

| KEY NO. | PART NO. | DESCRIPTION |
|---------|--------------|------------------------------|
| 2 | 532 42 20-27 | Shaft Asm., Lift |
| 3 | 532 19 52-31 | Lever Asm., Lift RH |
| 7 | 532 41 15-55 | Grip, Lever |
| 10 | 532 19 63-14 | Spring Torsion |
| 87 | 532 19 42-09 | Pin Cotter 7/16 Bow Tie Lock |
| 88 | 532 41 07-10 | Spring Lift Assist |
| 89 | 819 19 19-12 | Washer Clear Zinc |
| 90 | 532 19 42-08 | Pin Cotter 5/16 Bow Tie Lock |

| KEY NO. | PART NO. | DESCRIPTION |
|---------|--------------|----------------------------------|
| 91 | 532 19 51-81 | Link Asm Lift LH Rear |
| 97 | 817 00 06-12 | Screw Hex Wsh. THDR 3/8-16 x 3/4 |
| 98 | 532 19 52-70 | Link Lift Susp. Front Mower |
| 100 | 873 93 06-00 | Nut Centerlock 3/8-16 unc |
| 101 | 532 40 70-03 | Link Asm. Lift FXD |

NOTE: All component dimensions given in U.S. inches
1 inch = 25.4 mm

TRACTOR -- MODEL NUMBER YTH2042 (289610)

SEAT ASSEMBLY

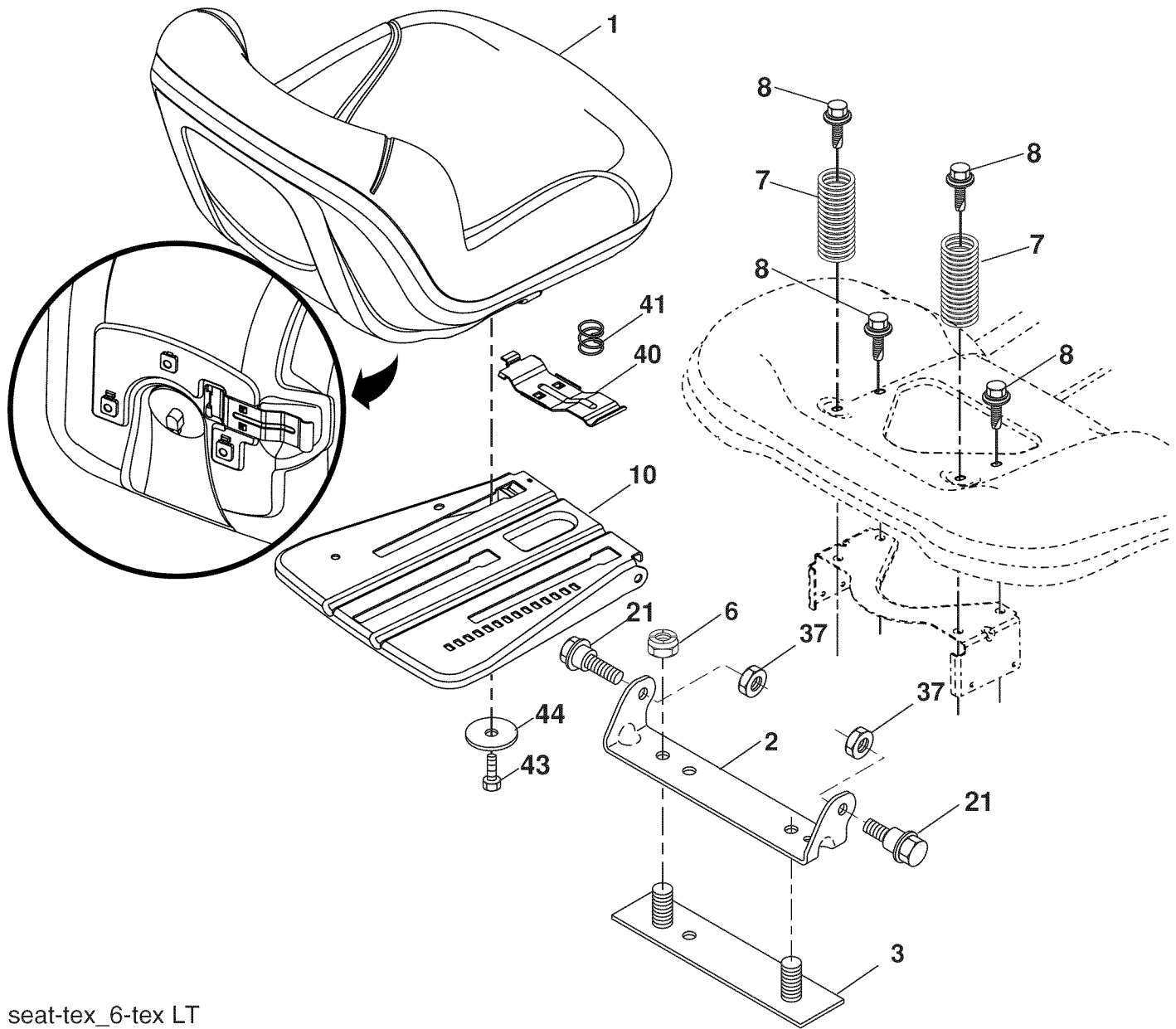

seat-tex_6-tex LT

| KEY NO. | PART NO. | DESCRIPTION |
|---------|--------------|-------------------------------|
| 1 | 532 42 40-67 | Seat |
| 2 | 532 18 01-66 | Bracket Pivot Fender |
| 3 | 532 14 06-75 | Strap, Asm Fender |
| 6 | 873 80 06-00 | Nut, Lock w/Ins. 3/8-16 unc |
| 7 | 532 12 41-81 | Spring, Seat Cprsn |
| 8 | 532 17 18-77 | Bolt 5/16-18 unc x 3/4 w/Sems |
| 10 | 532 19 69-77 | Pan, Seat |
| 21 | 532 17 18-52 | Bolt, Shoulder 5/16-18 |

| KEY NO. | PART NO. | DESCRIPTION |
|---------|--------------|-------------------------------|
| 37 | 873 80 05-00 | Nut, Lock 5/16-18 unc |
| 40 | 532 19 76-61 | Handle Slide Seat |
| 41 | 532 19 82-00 | Spring Latch Seat |
| 43 | 874 76 06-12 | Bolt Fin Hex 3/8-16 unc x 3/4 |
| 44 | 819 13 38-12 | Washer 13/32 x 2-3/8 x 12 Ga. |

NOTE: All component dimensions given in U.S. inches
1 inch = 25.4 mm

TRACTOR - - MODEL NUMBER YTH2042 (289610)
TUFFTORQ TRANSAXLE MODEL NUMBER K46BA

MODEL K46BA
7A646084100

ACTUAL PARTS
MAY NOT APPEAR
AS SHOWN

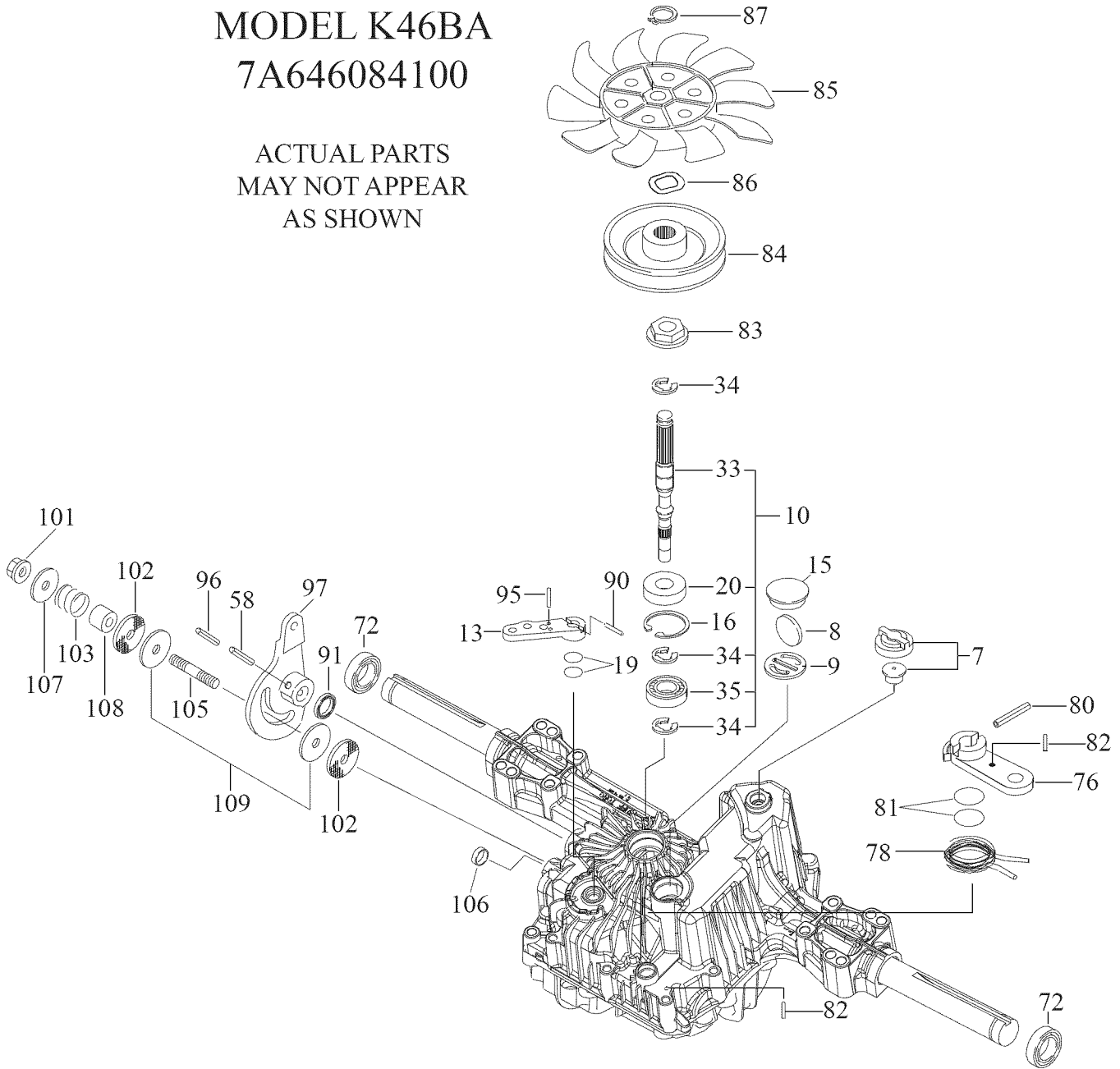

TRACTOR - - MODEL NUMBER YTH2042 (289610)
TUFFTORQ TRANSAXLE MODEL NUMBER K46BA

| KEY NO. | PART NO. | DESCRIPTION |
|------------|--------------|------------------------|
| 7 | 532 41 43-95 | Vent Valve 15 |
| 8 | 532 41 43-96 | Magnet |
| 9 | 532 41 43-97 | Magnet Holder |
| 10 | 532 41 59-23 | Pump Shaft/Bearing Kit |
| 13 | 532 41 43-98 | Bypass Lever |
| 15 | 532 41 43-99 | Sealing Cap 30 |
| 16 | 532 41 44-00 | Snap Ring C 35 |
| 19 | 532 41 44-01 | O-Ring 1a P10a |
| 20 | 532 41 44-02 | Seal Tc 153507 |
| 33 | 532 41 44-03 | Pump Shaft (Standard |
| 34 | 532 41 44-04 | E-Ring 15 |
| 35 | 532 41 44-05 | Bearing 6202c3 |
| 58 | 532 41 44-06 | Roll Pin 6 * 40 |
| 72 | 532 41 44-07 | Seal 19 * 32 * 8 |
| 76 | 532 41 44-08 | Brake Lever |
| 78 | 532 41 44-09 | Brake Return Spring |
| 80 | 532 41 44-10 | Spring Pin 5 * 32 |
| 81 | 532 41 44-11 | O-Ring 1a P12 |
| 82 | 532 41 44-12 | Spring Pin 4 * 16 |
| 83 | 532 41 44-13 | Spine Collar |
| 84 | 532 41 44-14 | Pulley L |
| 85 | 532 41 44-15 | Fan, Black |
| 86 | 532 41 44-16 | Wave Washer |
| 87 | 532 41 44-17 | Snap Ring |
| 90 | 532 41 44-18 | Spring Pin 3.0a * 20 |
| 91 | 532 41 44-19 | Oil Seal 16 * 22 * 03 |
| 95 | 532 41 58-50 | Spring Pin 3.0a * 16 |
| 96 | 532 41 44-20 | Roll Pin 3.5 * 40 |
| 97 | 532 41 44-21 | Control Lever |
| 101 | 532 41 42-16 | Lock Nut 10 |
| 102 | 532 41 44-23 | Washer 10 * 40 * 4 |
| 103 | 532 41 44-24 | Spring |
| 105 | 532 41 44-25 | Stud 10 * 60 |
| 106 | 532 41 44-26 | Sealing Cap 18 |
| 107 | 532 41 44-27 | Washer 10 * 36 * 2.8 |
| 108 | 532 41 44-28 | Collar 10 * 20 * 17 |
| 109 | 532 41 44-29 | Friction Plate Kit |

NOTE: All component dimensions given in U.S. inches
1 inch = 25.4 mm

TRACTOR - - MODEL NUMBER YTH2042 (289610)

BRIGGS ENGINE - MODEL NUMBER 331777, TYPE NUMBER 1372-B1

48 SHORT BLOCK

1058 OPERATOR'S MANUAL

1329 REPLACEMENT ENGINE

1330 REPAIR MANUAL

LIQUID GASKET AND THE BREATHER GASKET ARE INTERCHANGEABLE

1036 EMISSIONS LABEL

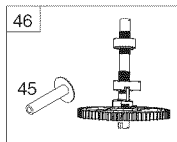
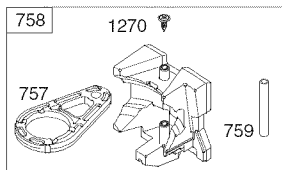
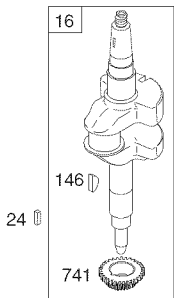
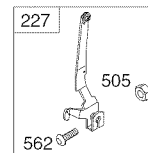
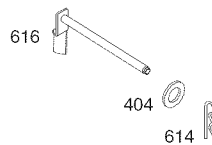
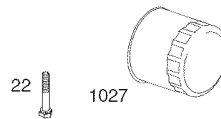
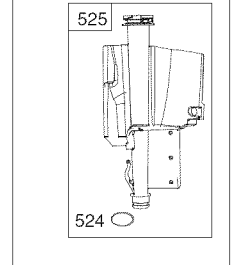
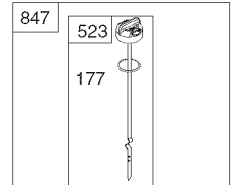
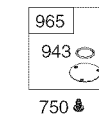
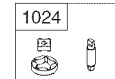
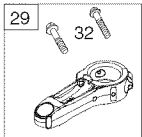
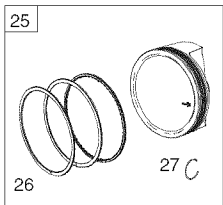
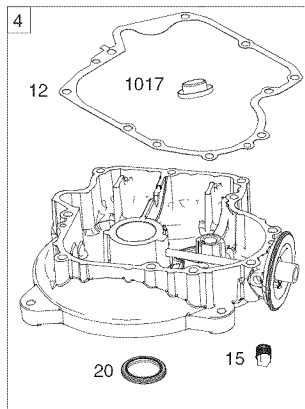
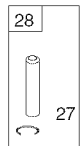
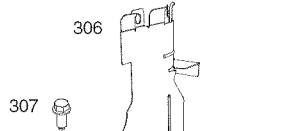
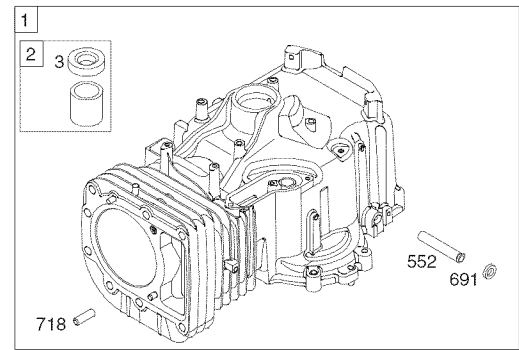
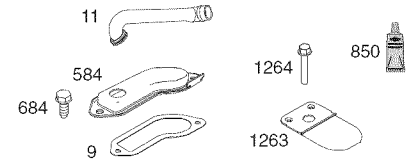
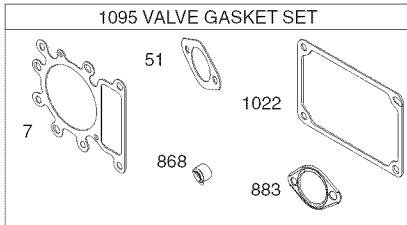
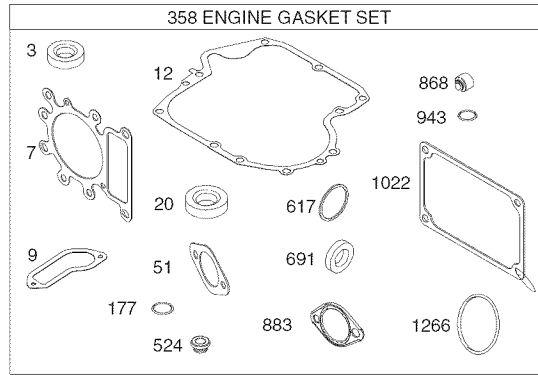
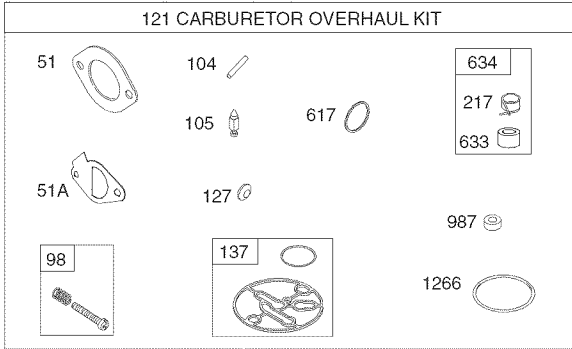

TRACTOR - - MODEL NUMBER YTH2042 (289610)

BRIGGS ENGINE - MODEL NUMBER 331777, TYPE NUMBER 1372-B1

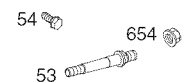
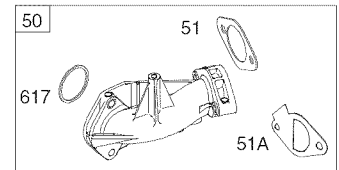
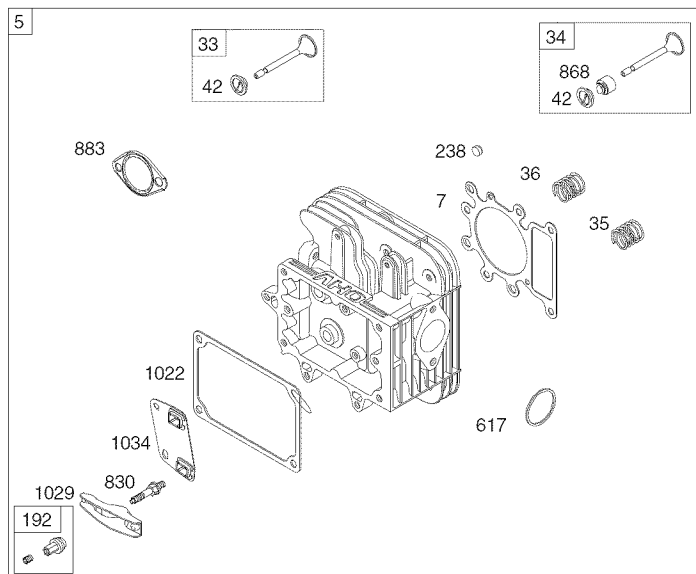
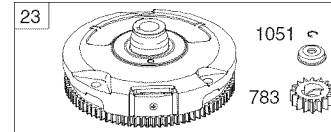
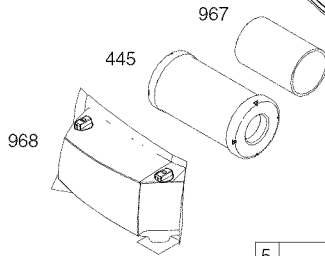
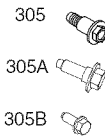
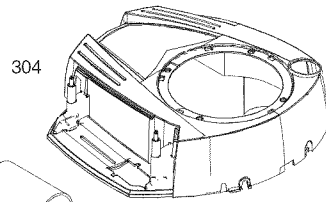
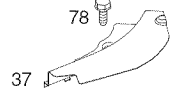
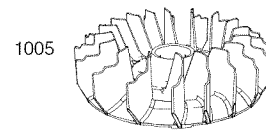
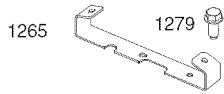
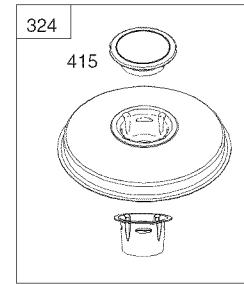
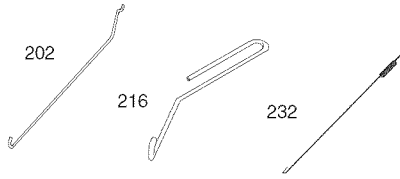
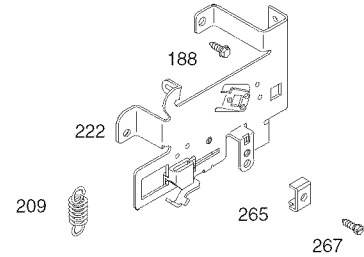
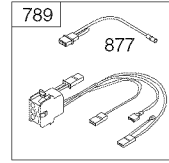
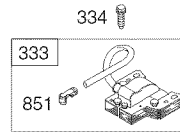
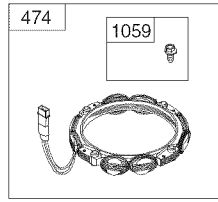
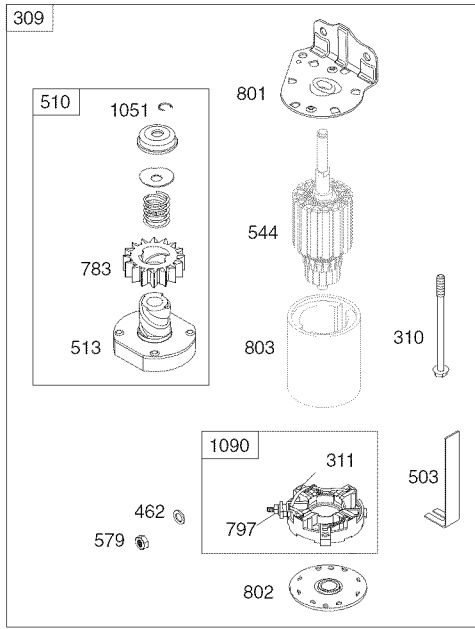

TRACTOR - - MODEL NUMBER YTH2042 (289610)
BRIGGS ENGINE - MODEL NUMBER 331777, TYPE NUMBER 1372-B1

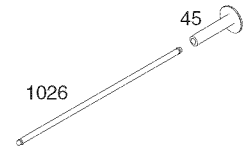
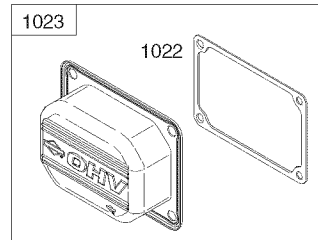
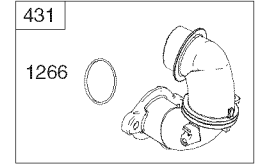
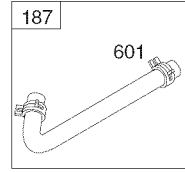
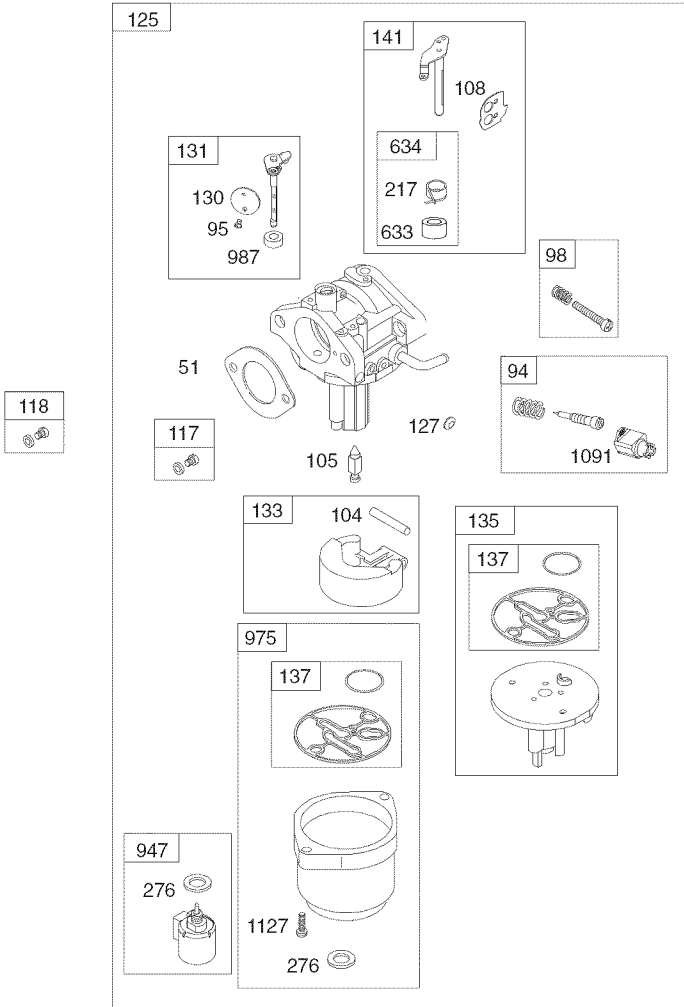

TRACTOR - - MODEL NUMBER YTH2042 (289610)

BRIGGS ENGINE - MODEL NUMBER 331777, TYPE NUMBER 1372-B1

| KEY NO. | PART NO. | DESCRIPTION | KEY NO. | PART NO. | DESCRIPTION |
|---------|-----------|----------------------------------|---------|----------|--|
| 1 | 796010 | Cylinder Assembly | 135 | 698780 | Tube-Fuel Transfer |
| 2 | 399265 | Bushing/Seal Kit (Magneto Side) | 137 | ♣ 698781 | Gasket-Float Bowl |
| 3 | • 391086s | Seal-Oil (Magneto Side) | 141 | 792777 | Kit-Choke Shaft |
| 4 | 697106 | Sump-Engine | 146 | 691639 | Key-Timing |
| 5 | 796025 | Head-Cylinder | 186 | 794873 | Connector-Hose (Intake Manifold) |
| 7 | ♦ 796584 | Gasket-Cylinder Head | 187 | 791805 | Line-Fuel (Formed) (Cut to Required Length) |
| 11 | 794683 | Tube-Breather | 188 | 691693 | Screw (Control Bracket) |
| 12 | • 697110 | Gasket-Crankcase | 192 | 691986 | Adjuster-Rocker Arm |
| 13 | 793988 | Screw (Cylinder Head) | 202 | 691841 | Link-Mechanical Governor |
| 15 | 690946 | Plug-Oil Drain | 209 | 692208 | Spring-Governor (Green) |
| 16 | 797579 | Crankshaft | 216 | 691840 | Link-Choke |
| 20 | • 795387 | Seal-Oil (PTO Side) | 217 | 695409 | Spring-Choke Return |
| 22 | 692125 | Screw (Crankcase Cover/Sump) | 222 | 694042 | Bracket-Control |
| 23 | 698281 | Flywheel | 227 | 691374 | Lever-Governor Control |
| 24 | 222698s | Key-Flywheel | 232 | 691842 | Spring-Governor Link |
| 25 | 796172 | Piston Assembly (Standard) | 238 | 691843 | Cap-Valve |
| | 796173 | Piston Assembly (.020" Oversize) | 240 | 394358s | Filter-Fuel |
| 26 | 791936 | Ring Set (Standard) | 265 | 691024 | Clamp-Casing |
| | 792649 | Ring Set (.020" Oversize) | 267 | 794904 | Screw (Casing Clamp) |
| 27 | 698469 | Lock-Piston Pin | 276 | 695410 | Washer-Sealing |
| 28 | 796007 | Pin-Piston | 304 | 796416 | Blower Housing |
| 29 | 794122 | Rod-Connecting | 305 | 697102 | Screw (Blower Housing) (Long) |
| 32 | 791118 | Screw (Connecting Rod) | 305A | 793376 | Screw (Blower Housing) (Short) |
| 33 | 792868 | Valve-Exhaust | 306 | 796006 | Shield-Cylinder |
| 34 | 791935 | Valve-Intake | 307 | 691003 | Screw (Cylinder Shield) |
| 35 | 691279 | Spring-Valve (Intake) | 309 | 693551 | Motor-Starter |
| 36 | 691279 | Spring-Valve (Exhaust) | 310 | 690323 | Screw (Starter Motor) |
| 37 | 697352 | Guard-Flywheel | 324 | 796308 | Screen/Cup Assembly |
| 42 | 499586 | Keeper-Valve | 333 | 795315 | Armature-Magneto |
| 43 | 691968 | Slinger-Governor/Oil | 334 | 691061 | Screw (Magneto Armature) |
| 45 | 690564 | Tappet-Valve | 337 | 491055s | Plug-Spark |
| 46 | 793880 | Gear-Cam | 358 | 796187 | Gasket Set-Engine |
| 48 | 697761 | Short Block | 404 | 691691 | Washer (Governor Crank) |
| 50 | 796180 | Manifold-Intake | 415 | 690283 | Plug (Intake Manifold) |
| 51♦♣ | 692137 | Gasket-Intake | 415A | 794129 | Plug (Cover/Retainer) |
| 51A | 796081 | Gasket-Intake | 431 | 697122 | Elbow-Intake |
| 53 | 690227 | Stud (Carburetor) | 445 | 698083 | Filter-Air Cleaner Cartridge |
| 54 | 691148 | Screw (Intake Manifold) | 462 | 691261 | Washer (Starter Cable) |
| 78 | 691003 | Screw (Flywheel Guard) | 474 | 696459 | Alternator |
| 94 | 793610 | Kit-Idle Mixture | 503 | 691532 | Strap-Starter |
| 95 | 690718 | Screw (Throttle Valve) | 505 | 691251 | Nut (Governor Control Lever) |
| 98 | 695408 | Kit-Idle Speed | 510 | 693699 | Drive-Starter |
| 104 | ♣ 694918 | Pin-Float Hinge | 513 | 692024 | Clutch-Drive |
| 105 | ♣ 696136 | Valve-Float Needle | 523 | 699908 | Dipstick |
| 108 | 695419 | Valve-Choke | 524 | • 691032 | Seal-Dipstick Tube |
| 117 | 843099 | Jet-Main (Standard) | 525 | 697184 | Tube-Dipstick |
| 118 | 790890 | Jet-Main (High Altitude) | 544 | | Armature-Starter (Order Starter Motor, Reference 309, 693551, for replacement) |
| 121 | 796184 | Kit-Carburetor Overhaul | 552 | 697144 | Bushing-Governor Crank |
| 125 | 796109 | Carburetor | 562 | 691119 | Screw (Governor Control Lever) |
| 127 | ♣ 690727 | Plug-Welch | 579 | 691029 | Nut (Starter Cable) |
| 130 | 699500 | Valve-Throttle | | | |
| 131 | 699501 | Kit-Throttle Shaft | | | |
| 133 | 694914 | Float-Carburetor | | | |

TRACTOR - - MODEL NUMBER YTH2042 (289610)

BRIGGS ENGINE - MODEL NUMBER 331777, TYPE NUMBER 1372-B1

| KEY NO. | PART NO. | DESCRIPTION | KEY NO. | PART NO. | DESCRIPTION |
|------------|-------------|--|------------|---------------|--|
| 584 | 794682 | Cover-Breather Passage (Use with Liquid Sealant, Reference 850) | 1026 | 692003 | Rod-Push (Intake) |
| | | | | 692011 | Rod-Push (Exhaust) |
| 585 | • 697109 | Gasket-Breather Passage | 1029 | 691751 | Arm-Rocker |
| 601 | 791850 | Hose-Clamp (Green) | 1034 | 690822 | Guide-Push Rod |
| 614 | 691620 | Pin-Cotter | 1036 | | Label-Emissions (Available from a Briggs & Stratton Authorized Dealer) |
| 616 | 692012 | Crank-Governor | | | |
| 617 | ♣ 692138 | Seal-O Ring (Intake Manifold) (Red) | 1040 | 698368 | Plate-Trim |
| 633 | 699813 | Seal-Choke/Throttle Shaft (Choke Shaft) | 1044 | 698139 | Screw (Flywheel) |
| 634 | ♣ 698779 | Spring/Seal Assembly (Choke Shaft) | 1051 | 691265 | Ring-Retaining |
| 635 | 691909 | Boot-Spark Plug | 1054 | 280275 | Tie-Cable |
| 643 | 698401 | Retainer-Air Filter | 1059 | 698516 | Kit-Screw/Washer |
| 654 | 690958 | Nut (Carburetor) | 1070 | 690363 | Screw (Flywheel Fan) |
| 684 | 697157 | Screw (Breather Assembly) | 1090 | 691293 | Retainer-Brush |
| 691 | • 692407 | Seal-Governor Shaft | 1091 | 691333 | Cap-Limiter |
| 718 | 690959 | Pin-Locating | 1095 | 794152 | Gasket Set-Valve |
| 724 | 697478 | Link-Starter Switch | 1119 | 691183 | Screw (Alternator) |
| 729 | 691224 | Clip-Wire | 1127 | 695407 | Screw (Float Bowl) |
| 741 | 697128 | Gear-Timing | 1263 | 697124 | Reed-Breather |
| 757 | 793242 | Link-Counterweight | 1264 | 697104 | Screw (Breather Reed) |
| 758 | 793763 | Counterweight | 1266 | ♣ 691917 | Seal-O Ring (Intake Elbow) |
| 759 | 697392 | Pin-Counterweight | | | |
| 783 | 693713 | Gear-Pinion | 1266A | ♣ 697123 | Seal-O Ring (Intake Elbow) |
| 789 | 698329 | Harness-Wiring | 1267 | 697419 | Latch-Blower Housing |
| 797 | 693167 | Nut (Brush Retainer) | 1270 | 793243 | Plug-AVS Counterweight |
| 801 | 691283 | Cap-Drive | 1329 | 33177-1372-B1 | Replacement Engine |
| 802 | 691286 | Cap-End | 1330 | 272147 | Repair Manual |
| 803 | | Housing-Starter (Order Starter Motor, Reference 309, 693551, for replacement) | | | |
| 830 | 691095 | Stud-Rocker Arm | | | |
| 842 | • 691031 | Seal-O Ring (Dipstick Tube) | | | |
| 847 | 790442 | Dipstick/Tube Assembly | | | |
| 850 | 100106 | Sealant-Liquid (Liquid Sealant is interchangeable with Breather Passage Gasket and/or Rocker Cover Gasket) | | | |
| 851 | 692424 | Terminal-Spark Plug | | | |
| 868 | ♦♦ 690968 | Seal-Valve | | | |
| 883 | • 692236 | Gasket-Exhaust | | | |
| 914 | 697551 | Screw (Rocker Cover) | | | |
| 947 | 699915 | Solenoid-Fuel | | | |
| 967 | 697015 | Filter-Pre Cleaner | | | |
| 968 | 698403 | Cover-Air Cleaner | | | |
| 975 | 699502 | Bowl-Fuel | | | |
| 987 | ♣ 698777 | Seal-Throttle Shaft | | | |
| 1005 | 796083 | Fan-Flywheel | | | |
| 1022 | ♦♦ 272475s | Gasket-Rocker Cover | | | |
| 1023 | 797421 | Cover-Rocker | | | |

- Engine Gasket Set Key No. 358
- ♦ Valve Gasket Set Key No. 1095
- ♣ Carburetor Overhaul Kit Key No. 121

NOTE: All component dimensions given in U.S. inches
1 inch = 25.4 mm

SERVICE NOTES

SERVICE NOTES

SUGGESTED GUIDE FOR SIGHTING SLOPES FOR SAFE OPERATION

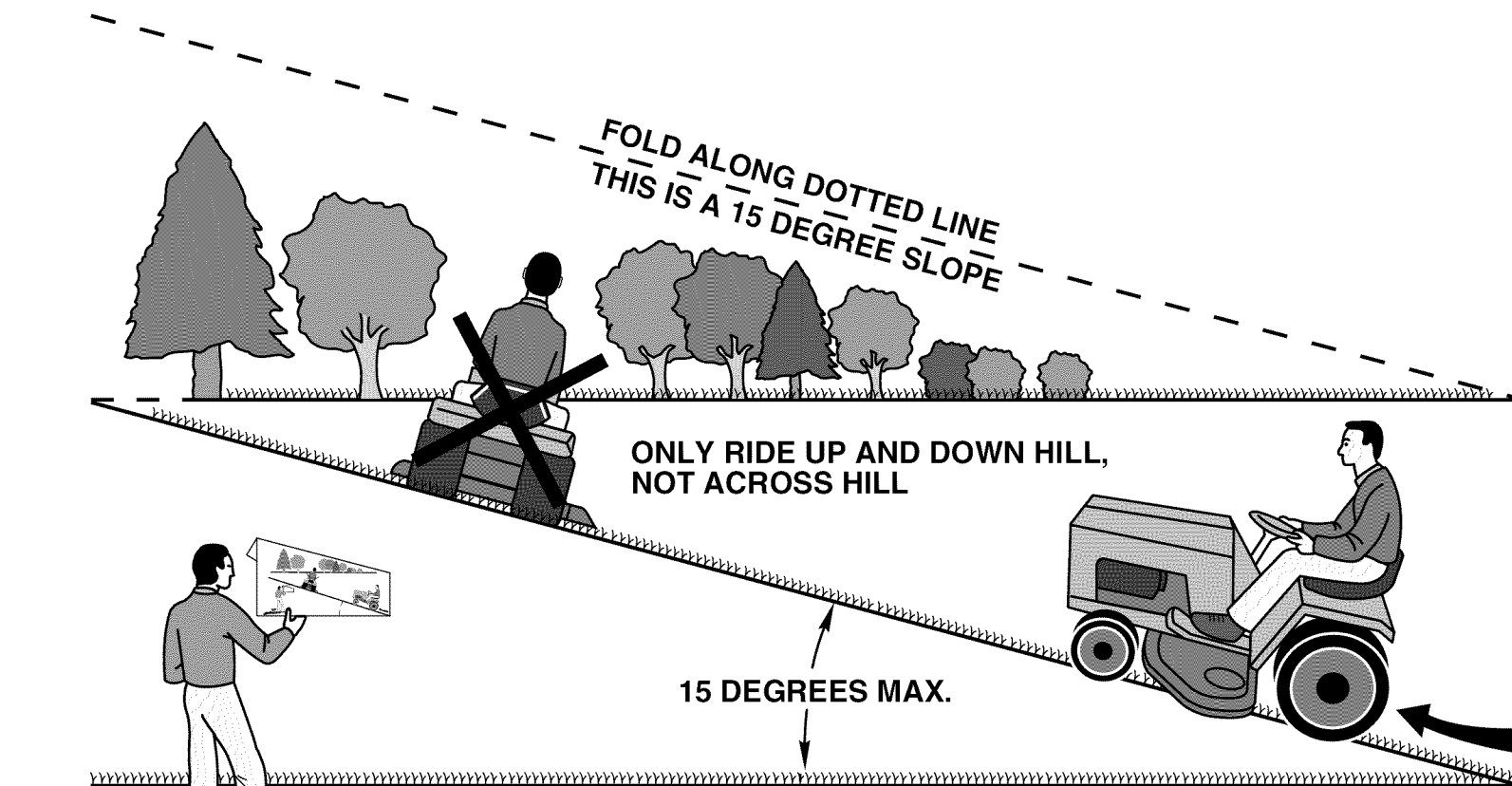

WARNING: To avoid serious injury, operate your tractor up and down the face of slopes, never across the face. Do not mow slopes greater than 15 degrees. Make turns gradually to prevent tipping or loss of control. Exercise extreme caution when changing direction on slopes.

1. Fold this page along dotted line indicated above.
2. Hold page before you so that its left edge is vertically parallel to a tree trunk or other upright structure.
3. Sight across the fold in the direction of hill slope you want to measure.
4. Compare the angle of the fold with the slope of the hill.

GENERAL: Craftsman products are warranted to be free from defects in materials or workmanship for a specific time period as set-out below (the "Warranty Period"). Warranties extend to the original purchaser of a Craftsman product only. Purchases made through an online auction or through any website other than www.sears.ca are excluded. The relevant Warranty Period commences on the original date of purchase. Within this period, SEARS CANADA, Inc. will, at its sole option, repair or replace any products or components which fail in normal use. Such repairs or replacement will be made at no charge to the customer for parts or labor, provided that the customer shall be responsible for any transportation cost.

EXCLUSIONS: This warranty does not cover failures due to normal wear, abuse, misuse, neglect (including but not limited to the use of stale fuel, dirt, abrasives, moisture, rust, corrosion, or any adverse reaction due to improper storage or use habits), improper maintenance or failure to follow maintenance guidelines and/or instructions, failure to operate the product in accordance with the owner's manual or any additional instructions or information provided at the time of purchase or in subsequent communications with the original purchaser, accident or unauthorized alterations or repairs made or attempted by others. Also excluded from warranty coverage - except as provided below - are the following: maintenance, adjustments, components subject to wear including but not limited to: cosmetic components, belts, blades, blade adapters, bulbs, tires, filters, guide bars, lubricants, seats, grips, recoil assy's, saw chains and bars, trimmer lines and spools, spark plugs, starter ropes and tines, and discoloration resulting from ultraviolet light. Any product missing the model and/or serial number identification label will be disqualified from coverage under this warranty.

REPAIRS: Repairs have a 90 day warranty. If the defective product is still within the Warranty Period, then the new warranty is 90 days from the date of repair or to the end of the original Warranty Period, whichever period is longer.

DISCLAIMERS: THE WARRANTIES AND REMEDIES CONTAINED HEREIN ARE EXCLUSIVE AND IN LIEU OF ALL OTHER WARRANTIES, WHETHER ORAL OR WRITTEN (OTHER THAN AS STATED HEREIN), AND WHETHER EXPRESS, IMPLIED OR STATUTORY, INCLUDING BUT NOT LIMITED TO ANY. THIS WARRANTY GIVES YOU SPECIFIC LEGAL RIGHTS, WHICH MAY VARY FROM PROVINCE TO PROVINCE.

IN NO EVENT SHALL SEARS BE LIABLE FOR ANY INCIDENTAL, SPECIAL, INDIRECT OR CONSEQUENTIAL DAMAGES, WHETHER RESULTING FROM THE USE, MISUSE OR INABILITY TO USE THE PRODUCT OR FROM DEFECTS IN THE PRODUCT. THE EXCLUSIONS IN THIS PARAGRAPH SHALL NOT APPLY IN JURISDICTIONS WHERE APPLICABLE LAW DOES NOT ALLOW FOR THE EXCLUSION OF INCIDENTAL OR CONSEQUENTIAL DAMAGES. IN SUCH JURISDICTIONS, THIS PARAGRAPH SHALL NOT APPLY, BUT THE REMAINING PROVISIONS OF THIS DOCUMENT SHALL REMAIN VALID.

SEARS retains the exclusive right to repair or replace the product or offer a full refund of the purchase price at its sole discretion. SUCH REMEDY SHALL BE YOUR SOLE AND EXCLUSIVE REMEDY FOR ANY BREACH OF WARRANTY.

CUSTOMER RESPONSIBILITIES: In addition to complying with all suggested maintenance guidelines and instructions, customers' obligations shall include but shall not be limited to: operating the product in accordance with the owner's manual or any additional instructions or information provided at the time of purchase or in subsequent communications to the purchaser from time to time, exhibit reasonable care in the use, operation, maintenance, general upkeep and storage of the product. Failure to comply with these requirements will void any applicable warranty.

LIST OF APPLICABLE WARRANTY PERIODS: The following list contains the applicable Warranty Period for your Craftsman product and is based on a combination of the type of product or component and the intended and actual use of the product or component:

1. **90 DAYS:** Craftsman products intended for use or actually used for commercial, institutional, professional or income-producing purposes
2. **2 YEARS:** Craftsman riding lawn mowers, yard and garden tractors, walk behind mowers, tillers, brush cutters, snow blowers, handheld blowers, backpack blowers, hedge trimmers and electrical products for noncommercial, nonprofessional, non-institutional, or non-income-producing use, except for those components which are part of engine systems manufactured by third party engine manufacturers for which the purchase has received a separate warranty with product information supplied at the time of purchase.
3. **1 YEAR:** Craftsman power cutters, stump grinders, pole pruners, gas chain saws, electric chain saws, trimmer attachments, baggers and pole saws for noncommercial, nonprofessional, non-institutional, or non-income-producing use.
4. **90 DAYS:** All defective batteries, which will be replaced during this 90-day Warranty Period.
5. **60 DAYS:** Additional Warranty Period of 60 days will apply to adjustments and worn products or components BUT DOES NOT INCLUDE WEAR OR ADJUSTMENTS for products used for commercial, institutional, professional or income-producing purposes. Wear items include but are not limited to: belts, blades, tires, spark plugs, air filters, chains, shear bolts, skid plates, scraper bars, drift cutters, ropes, tines, collection bags and pulleys.

As the Warranty Period runs from the date of purchase and NOT from the date that a product is delivered, opened, assembled or first used, please ensure during this time period that your product or component has been assembled and tested for correction operation regardless of when you intend to actually use it. Claims made after the Warranty Period has expired will not be honored.

PROOF OF PURCHASE/DOCUMENTATION: Warranty coverage is conditioned upon the original purchaser furnishing SEARS CANADA or its authorized third party service provider if applicable, with the original sales receipt or other adequate written proof of the original purchase date and identification of the product. In the event that the original purchaser is unable to provide a company of the original sales receipt, SEARS CANADA Inc. reserves the right to determine in its sole discretion what other written proof of the original purchase date and identification of the product is acceptable.