

zenith



Please read this operating guide carefully before using the Monitor.
Keep the operating guide with the Monitor.
For future reference, write down the serial number on the back of the Monitor in the space provided below.

Model number :
Serial number :

PLASMA DISPLAY PANEL

**P42W22
P42W22B
P42W22H**

OWNER'S MANUAL

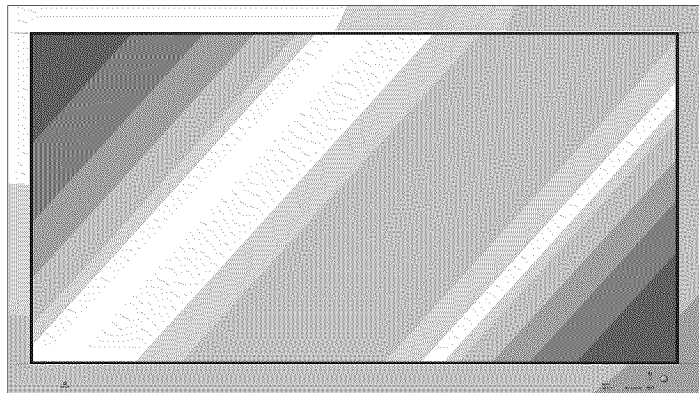

Colored dots on the screen

A PDP (Plasma Display Panel), depending on its size, contains from 0.9 to 2.2 million individual cells. Even with advanced technology it is inevitable that a few defective cells may be found in the PDP. These defective cells may be visible as colored dots. We continually strive to minimize the number of defective cells but the existence of a few such defects will not be considered as sufficient reason for exchange or refund.

Earth wire should be connected.

- If the earth wire is not connected, there is possible a danger of electric shock caused by the current leakage.
- If grounding methods are not possible, a separate circuit breaker should be employed and installed by a qualified electrician.
- Do not connect ground to telephone wires, lightning rods or gas pipe.

WARNING

TO REDUCE THE RISK OF FIRE AND ELECTRIC SHOCK, DO NOT EXPOSE THIS PRODUCT TO RAIN OR MOISTURE.

Power supply cord/appliance coupler is used as the main disconnect device, and as such shall be easily accessible after installation.

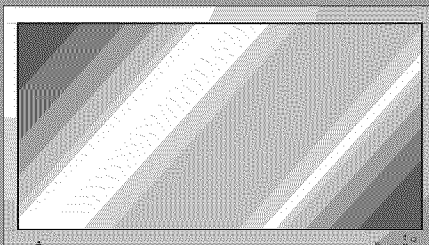

Table of Contents

First Step

WARNINGS	4
SAFETY INSTRUCTIONS	5

Monitor Overview

Front Panel Controls	8
Connection Panel Overview	9
Remote Control Key Functions/Accessories	10
Monitor Installation	12

Equipment Connections and Setup

VCR Setup	14
Cable TV Setup	16
External AV Source Setup	17
DVD Setup	18
DTV Setup	19
PC Setup	20
PC Mode Feature Check (Overview)	22
PC Mode Adjustments	23
Picture In Picture (PIP) Function	26
Remote Control Setup	29

Basic Features Setup and Operation

Turning on the Monitor	30
Menu Language Selection	31
Checking Features	32

Sleep Timer

Setting Sleep Timer (Monitor turn-off time)	33
---	----

Picture & Sound

Auto Picture Control	34
Adjusting Picture Appearance	35
DRP (Digital Reality Picture)	36
Adjusting Sound: Bass, Treble, Balance	37
Auto Sound Control	38
AVL (Auto Volume Leveler)	39

Special Features

Using Still Function	40
Using the Screen Options	41
Adjusting OSD Transparency	42
Color Temperature Adjustments	43
Setting Picture Format	44
External Control Device Setup	45

Others

Maintenance	53
Troubleshooting Checklist	54
Product Specifications	55

Keep this manual
with Monitor for
future easy reference

WARNINGS



WARNING

RISK OF ELECTRIC SHOCK
DO NOT OPEN



WARNING:

TO REDUCE THE RISK OF ELECTRIC SHOCK DO NOT REMOVE COVER (OR BACK). NO USER SERVICEABLE PARTS INSIDE. REFER TO QUALIFIED SERVICE PERSONNEL.



The lightning flash with arrowhead symbol, within an equilateral triangle, is intended to alert the user to the presence of uninsulated “dangerous voltage” within the product’s enclosure that may be of sufficient magnitude to constitute a risk of electric shock to persons.



The exclamation point within an equilateral triangle is intended to alert the user to the presence of important operating and maintenance (servicing) instructions in the literature accompanying the appliance.

WARNING:

TO PREVENT FIRE OR SHOCK HAZARDS, DO NOT EXPOSE THIS PRODUCT TO RAIN OR MOISTURE.

CAUTION:

Do not attempt to modify this product in any way without written authorization from Zenith Electronics Corporation. Unauthorized modification could void the user’s authority to operate this product.

COMPLIANCE:

The responsible party for this product’s compliance is:
Zenith Electronics Corporation
2000 Millbrook Drive
Lincolnshire, IL 60069, USA
Phone: 1-847-941-8000

FCC NOTICE

• P42W22 : A Class A digital device

This equipment has been tested and found to comply with the limits for a Class A digital device, pursuant to Part 15 of the FCC Rules. These limits are designed to provide reasonable protection against harmful interference when the equipment is operated in a commercial environment. This equipment generates, uses, and can radiate radio frequency energy and, if not installed and used in accordance with the instruction manual, may cause harmful interference to radio communications. Operation of this equipment in a residential area is likely to cause harmful interference in which case the user will be required to correct the interference at his own expense.

• P42W22B, P42W22H : A Class B digital device

This equipment has been tested and found to comply with the limits for a Class B digital device, pursuant to Part 15 of the FCC Rules. These limits are designed to provide reasonable protection against harmful interference in a residential installation. This equipment generates, uses and can radiate radio frequency energy and, if not installed and used in accordance with the instructions, may cause harmful interference to radio communications. However, there is no guarantee that interference will not occur in a particular installation. If this equipment does cause harmful interference to radio or television reception, which can be determined by turning the equipment off and on, the user is encouraged to try to correct the interference by one or more of the following measures:

- Reorient or relocate the receiving antenna.
- Increase the separation between the equipment and receiver.
- Connect the equipment into an outlet on a circuit different from that to which the receiver is connected.
- Consult the dealer or an experienced radio/TV technician for help.

SAFETY INSTRUCTIONS

Important safeguards for you and your new product

Your product has been manufactured and tested with your safety in mind. However, improper use can result in potential electrical shock or fire hazards. To avoid defeating the safeguards that have been built into your new product, please read and observe the following safety points when installing and using your new product, and save them for future reference.

Observing the simple precautions discussed in this booklet can help you get many years of enjoyment and safe operation that are built into your new product.

This product complies with all applicable U.S. Federal safety requirements, and those of the Canadian Standards Association.

1. Read Instructions

All the safety and operating instructions should be read before the product is operated.

2. Follow Instructions

All operating and use instructions should be followed.

3. Retain Instructions

The safety and operating instructions should be retained for future reference.

4. Heed Warnings

All warnings on the product and in the operating instructions should be adhered to.

5. Cleaning

Unplug this product from the wall outlet before cleaning. Do not use liquid cleaners or aerosol cleaners. Use a damp cloth for cleaning.

6. Water and Moisture

Do not use this product near water, for example, near a bath tub, wash bowl, kitchen sink, or laundry tub, in a wet basement, or near a swimming pool.

7. Accessories Carts and Stands

Do not place this product on a slippery or tilted surface, or on an unstable cart, stand, tripod, bracket, or table. The product may

slide or fall, causing serious injury to a child or adult, and serious damage to the product. Use only with a cart, stand, tripod, bracket, or table recommended by the manufacturer, or sold with the product. Any mounting of the product should follow the manufacturer's instructions, and should use a mounting accessory recommended by the manufacturer.

8. Transporting Product

A product and cart combination should be moved with care. Quick stops, excessive force, and uneven surfaces may cause the product and cart combination to overturn.



PORTABLE CART WARNING

9. Attachments

Do not use attachments not recommended by the product manufacturer as they may cause hazards.

10. Ventilation

Slots and openings in the cabinet are provided for ventilation and to ensure reliable operation of the product and to protect it from overheating, and these openings must not be blocked or covered.

(Continued on next page)

SAFETY INSTRUCTIONS

(Continued from previous page)

The openings should never be blocked by placing the product on a bed, sofa, rug, or other similar surface. This product should not be placed in a built-in installation such as a bookcase or rack unless proper ventilation is provided or the manufacturer's instructions have been adhered to.

11. Power Sources

This product should be operated only from the type of power source indicated on the marking label. If you are not sure of the type of power supply to your home, consult your product dealer or local power company. For products intended to operate from battery power, or other sources, refer to the operating instructions.

12. Power-Cord Polarization

This product is equipped with a three-wire grounding type plug, a plug having a third (grounding) pin. This plug will only fit into the grounding-type power outlet. This is a safety feature. If you are unable to insert the plug into the outlet, contact your electrician to replace your obsolete outlet. Do not defeat the safety purpose of the grounding-type plug.

13. Power-Cord Protection

Power-supply cords should be routed so that they are not likely to be walked on or pinched by items placed upon or against them, paying particular attention to cords at plugs, convenience receptacles, and the point where they exit from the product.

14. Outdoor Antenna Grounding

If an outside antenna or cable system is connected to the product, be sure the antenna or cable system is grounded so as to provide some protection against voltage surges and built-up static charges. Article 810 of the National Electrical Code (U.S.A.), ANSI/ NFPA 70 provides information with regard to proper grounding of the mast and supporting structure, grounding of the lead-

in wire to an antenna discharge unit, size of grounding conductors, location of antenna-discharge unit, connection to grounding electrodes, and requirements for the grounding electrode.

Example of Grounding According to National Electrical Code Instructions

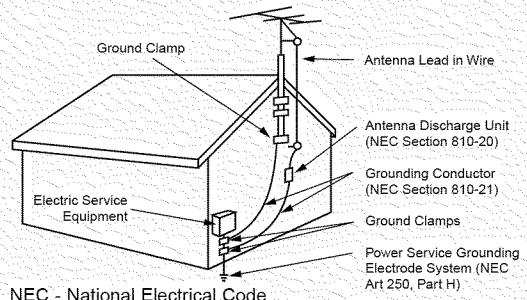

15. Lightning

For added protection for this product (receiver) during a lightning storm, or when it is left unattended and unused for long periods of time, unplug it from the wall outlet and disconnect the antenna or cable system. This will prevent damage to the product due to lightning and power-line surges.

16. Power Lines

An outside antenna system should not be located in the vicinity of overhead power lines or other electric light or power circuits, or where it can fall into such power lines or circuits. When installing an outside antenna system, extreme care should be taken to keep from touching such power lines or circuits as contact with them might be fatal.

17. Overloading

Do not overload wall outlets and extension cords as this can result in a risk of fire or electric shock.

18. Object and Liquid Entry

Never push objects of any kind into this

product through openings as they may touch dangerous voltage points or short-out parts that could result in a fire or electric shock. Never spill liquid of any kind on the product.

19. Servicing

Do not attempt to service this product yourself as opening or removing covers may expose you to dangerous voltage or other hazards. Refer all servicing to qualified service personnel.

20. Damage Requiring Service

Unplug this product from the wall outlet and refer servicing to qualified service personnel under the following conditions:

- a. If the power-supply cord or plug is damaged.
- b. If liquid has been spilled, or objects have fallen into the product.
- c. If the product has been exposed to rain or water.
- d. If the product does not operate normally by following the operating instructions. Adjust only those controls that are covered by the operating instructions as an improper adjustment of other controls may result in damage and will often require extensive work by a qualified technician to restore the product to its normal operation.
- e. If the product has been dropped or the cabinet has been damaged.
- f. If the product exhibits a distinct change in performance.

21. Replacement Parts

When replacement parts are required, be sure the service technician has used replacement parts specified by the manufacturer or have the same characteristics as the original part. Unauthorized substitutions may result in fire, electric shock, or other hazards.

22. Safety Check

Upon completion of any service or repairs to this product, ask the service technician to perform safety checks to determine that the product is in proper operating condition.

23. Wall or Ceiling Mounting

The product should be mounted to a wall or ceiling only as recommended by the manufacturer. The product may slide or fall, causing serious injury to a child or adult, and serious damage to the product.

24. Heat

The product should be situated away from heat sources such as radiators, heat registers, stoves, or other products (including amplifiers) that produce heat.

Front Panel Controls

Front Panel Controls

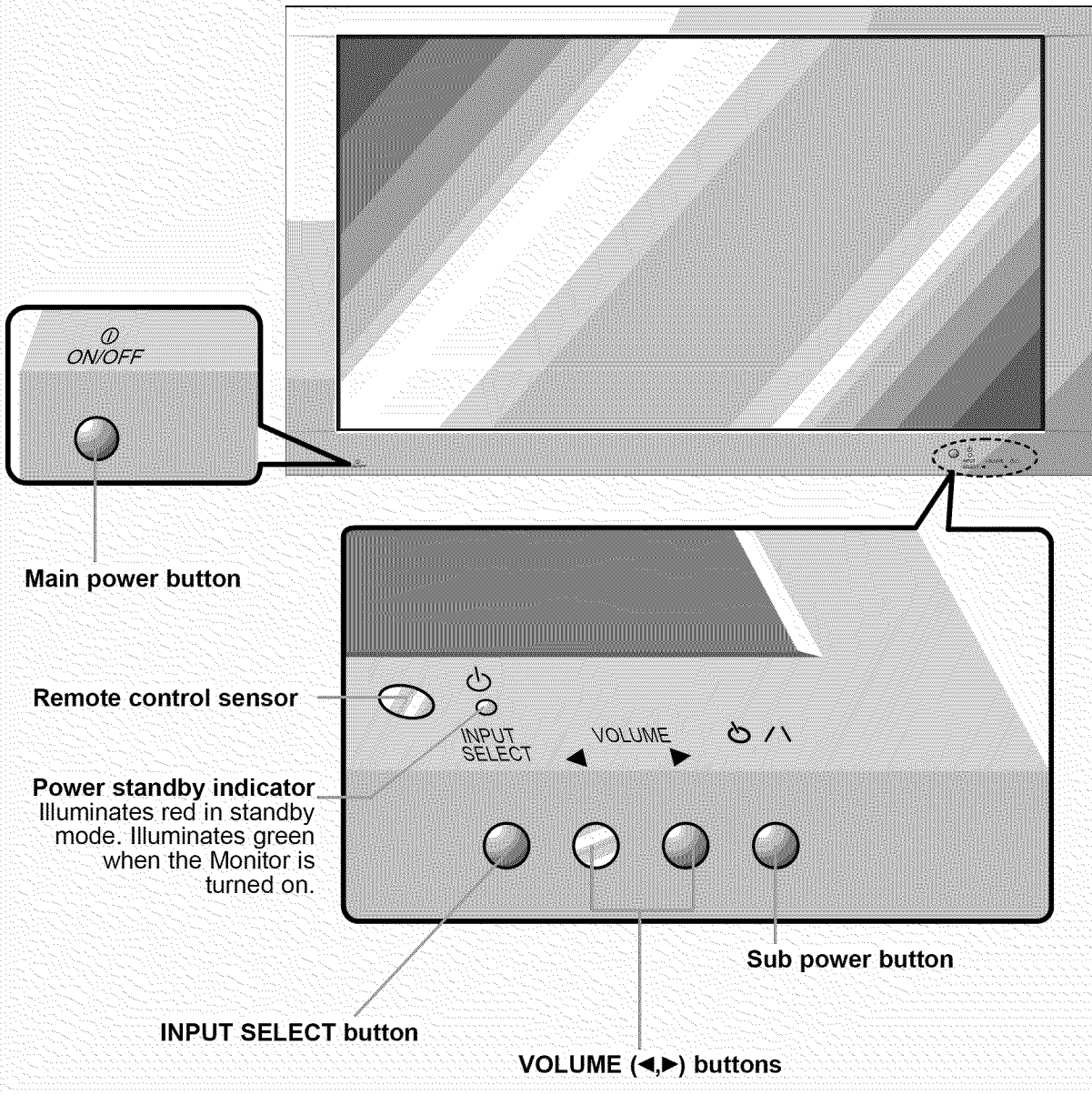

Connection Panel Overview

Back Panel

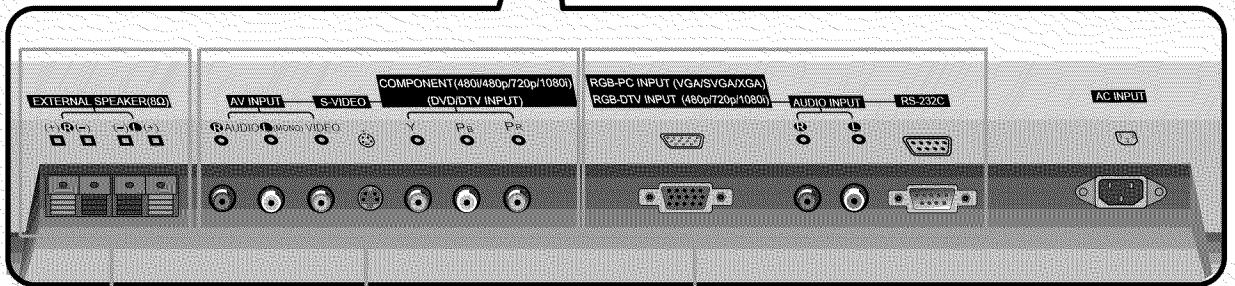
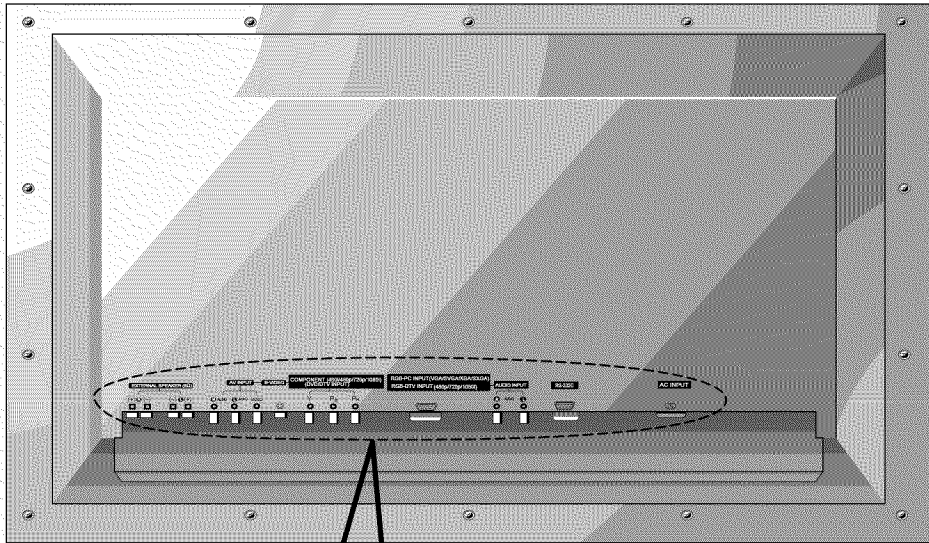

EXTERNAL SPEAKER
(8 ohm output)

RGB-PC INPUT (VGA/SVGA/XGA)
RGB-DTV INPUT (480p/720p/1080i) /
AUDIO INPUT/
RS-232C jacks

A/V INPUT /
S-VIDEO/
COMPONENT (480i/480p/720p/1080i)
DVD/DTV INPUT jacks

Remote Control Key Functions/Accessories

- When using the remote control aim it at the remote control sensor on the Monitor.

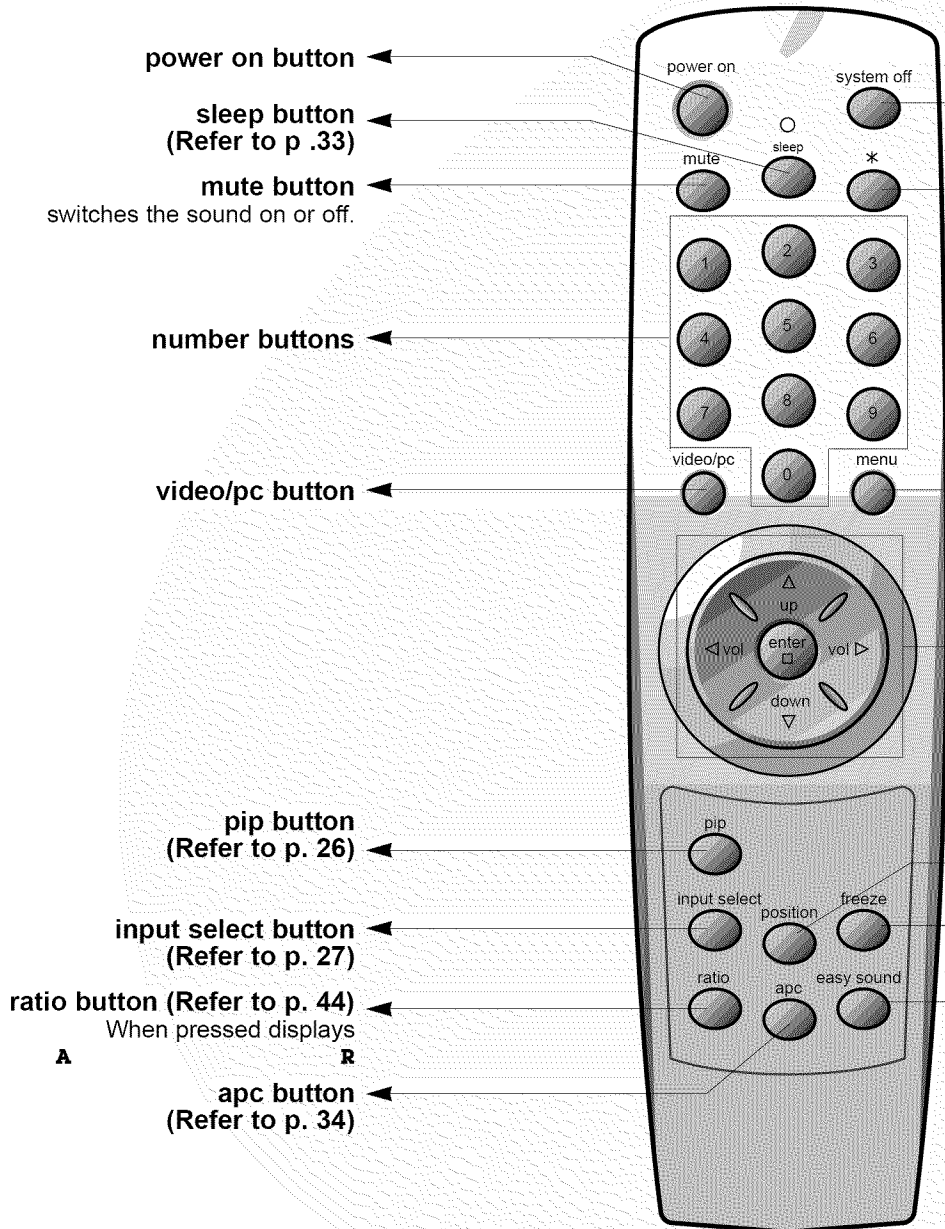

system off button

Turns Monitor standby mode off.

No function

menu button

**enter button
up/down buttons
vol buttons**

**position button
(Refer to p. 27)**

**freeze button
(Refer to p. 40)**

easy sound button (Refer to p. 38)
When pressed displays
D A S P on
screen.

video/pc button on the remote control

Each press of this button changes the mode as shown below.

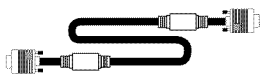
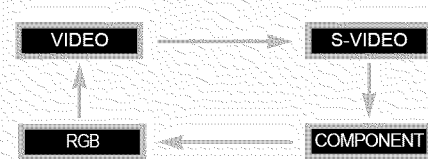

D-sub 15 pin cable



Power cord



Owner's Manual

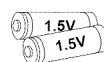

Alkaline batteries



Remote control

Accessories

Monitor Installation

- It is recommended that this product only be used at an altitude of less than 6562 feet (2000m) to get the best quality picture and sound.
- This plasma display is designed to be mounted horizontally (wide viewing).
- Your P42W22, P42W22B, P42W22H models (Monitor) can be installed on a wall as shown below, or on a desktop pedestal as shown on the next page. Wall mount and stands are optional, and are not supplied with the monitor.

Wall Mount Installation

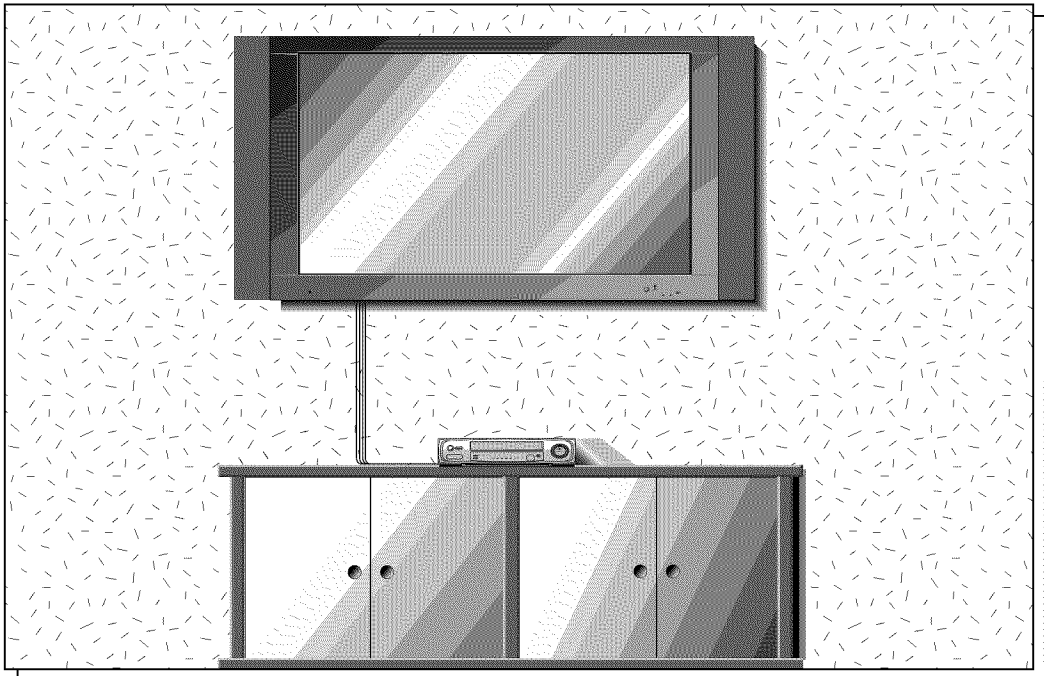

- The monitor can be installed on the wall as shown above. (For further information, refer to the optional Tilt/Wall Mounting Bracket Installation and Setup Guide.)
- Speakers are optional, and shown for illustration only.

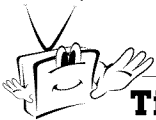

Tip

- Install this monitor only in a location where adequate ventilation is available.

a.  (Wall mount minimum allowable clearances for adequate ventilation)

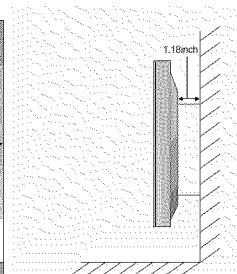
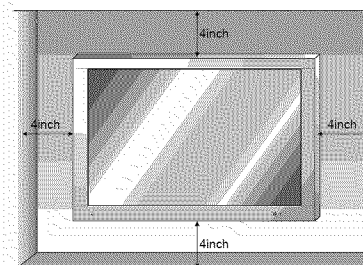

Desktop Pedestal Installation

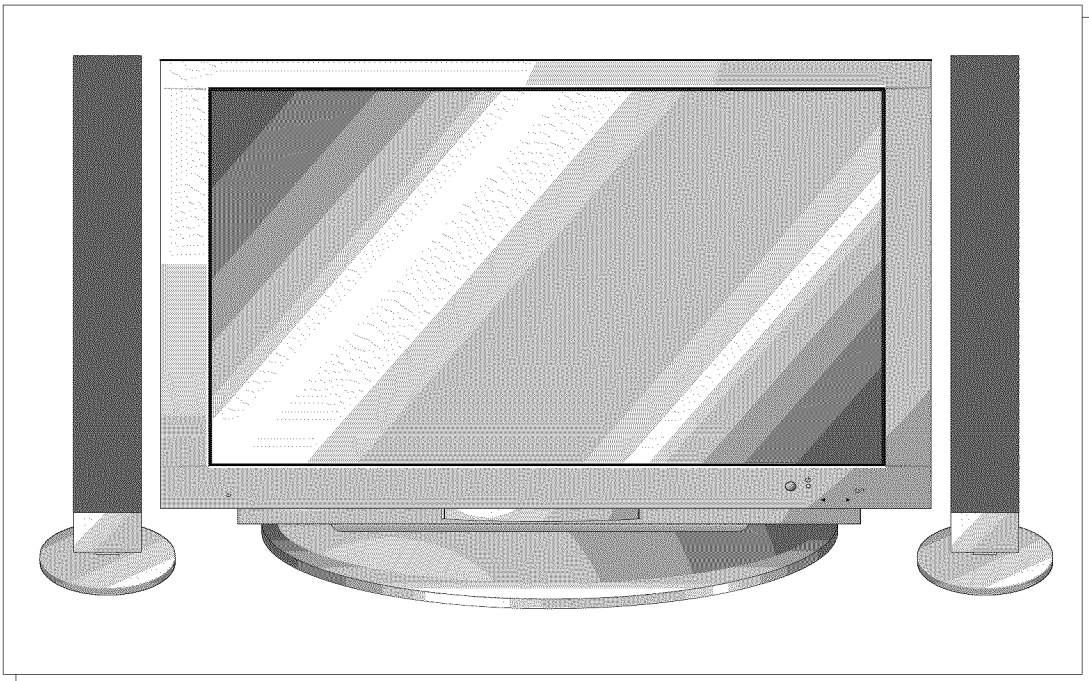

- The Monitor can be mounted on a desk as shown above.
(For further information, refer to the optional Desktop Stand Installation and Setup Guide.)
- Speakers and speaker stands shown are optional, and shown for example only.

- b.  (Pedestal mount minimum allowable clearances for adequate ventilation)

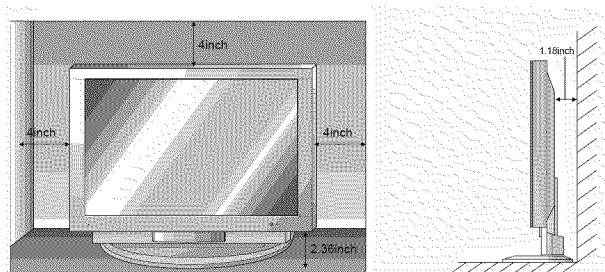

VCR Setup

- As shown below, when connecting the Monitor to a VCR, match the colors of AV input jacks on the Monitor with the output jacks on the VCR: Video = yellow, Audio (Left) = white, Audio (Right) = red.
- If you have a mono VCR, connect the audio cable from the VCR to the AUDIO (L/MONO) input on the Plasma Monitor.
- If you connect an S-VIDEO VCR to the S-VIDEO input, the picture quality is improved, compared to connecting a regular VCR to the Video input.
- Avoid having a fixed image remain on the screen for a long period of time. A frozen still picture from a VCR (or if a CH label is displayed) displayed on the screen for prolonged periods will result in an image ghost remaining even when you change the image. Avoid prolonged display of a still image.

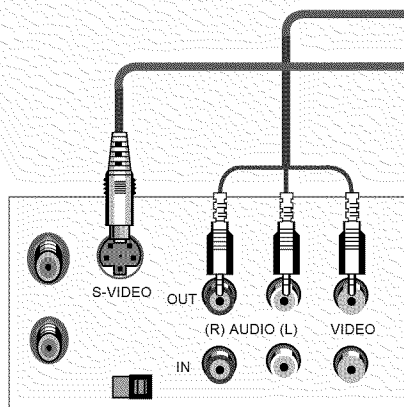

Back panel of VCR



Tip

- To avoid picture noise (interference), leave an adequate distance (20 inches or more) between the VCR and monitor.

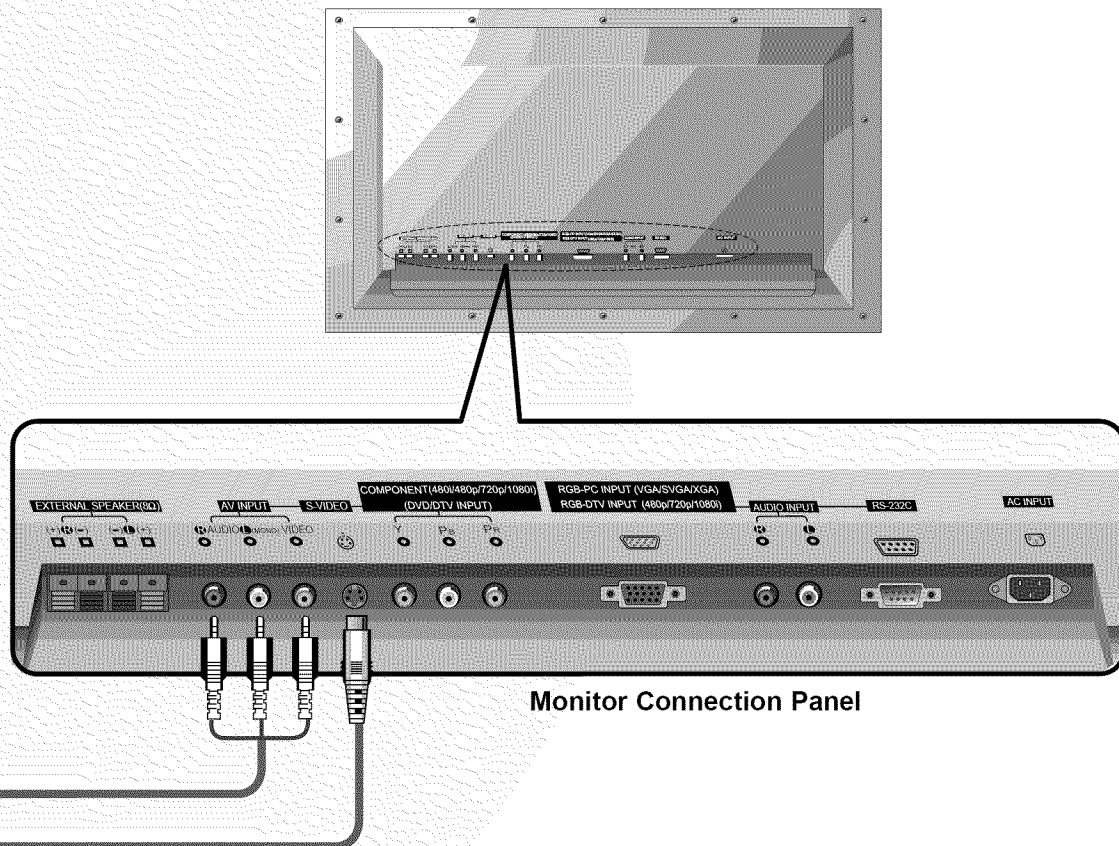

To watch VCR

video/pc



- 1 Use the **video/pc** button on the remote control to select **VIDEO**.
(When connecting S-Video, select the **S-VIDEO** option.)

- 2 Insert a video tape into the VCR and press the **PLAY** button on the VCR. See VCR owner's manual.

Cable TV Setup

- After subscribing to a cable TV service from a local provider and installing a converter, you can watch cable TV programming. This monitor cannot display TV programming without a TV tuner or cable TV converter box.

Speakers shown for illustration only.

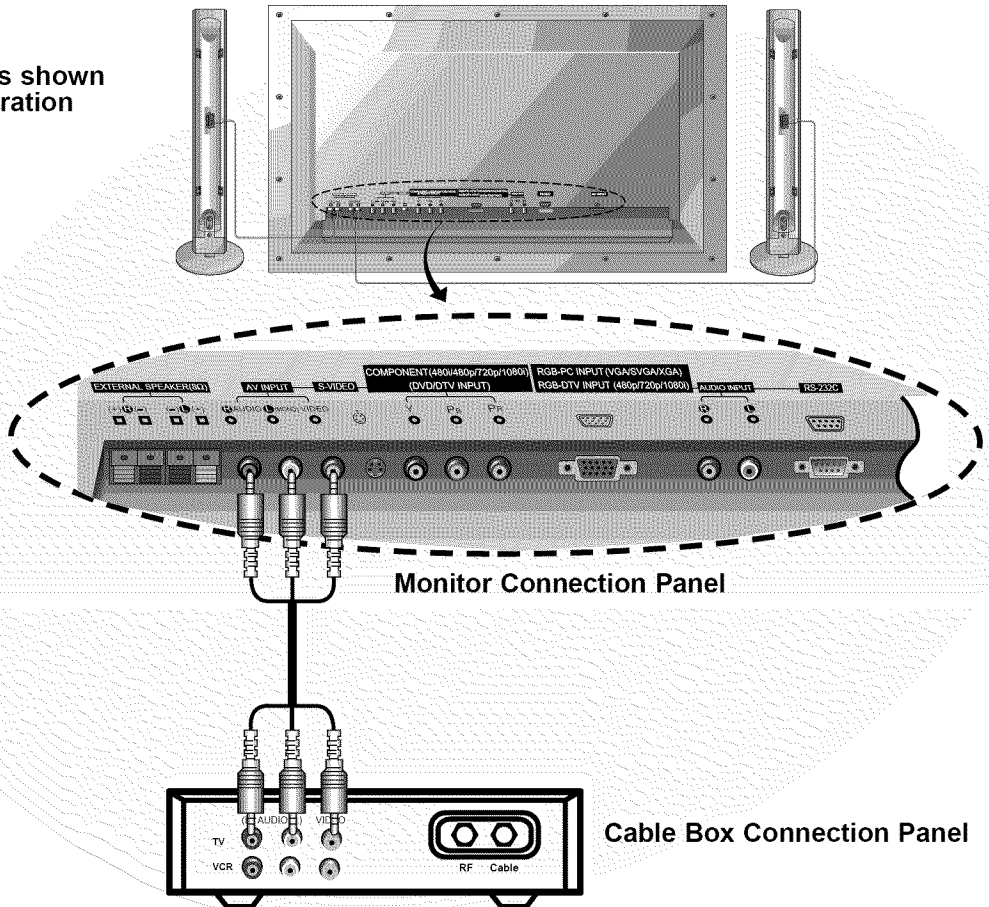

To watch cable TV

- 1 Use the **video/pc** button on the remote control to select the **VIDEO** source.



- 2 Tune to cable service provided channels using the cable box.



Tip

- For further information regarding cable TV service, contact your local cable TV service provider(s).

External AV Source Setup

- As shown below, when connecting the Monitor to an external source, match the colors of AV input jacks on the Monitor with the output jacks on the audio/video equipment: Video = yellow, Audio (Left) = white, Audio (Right) = red.

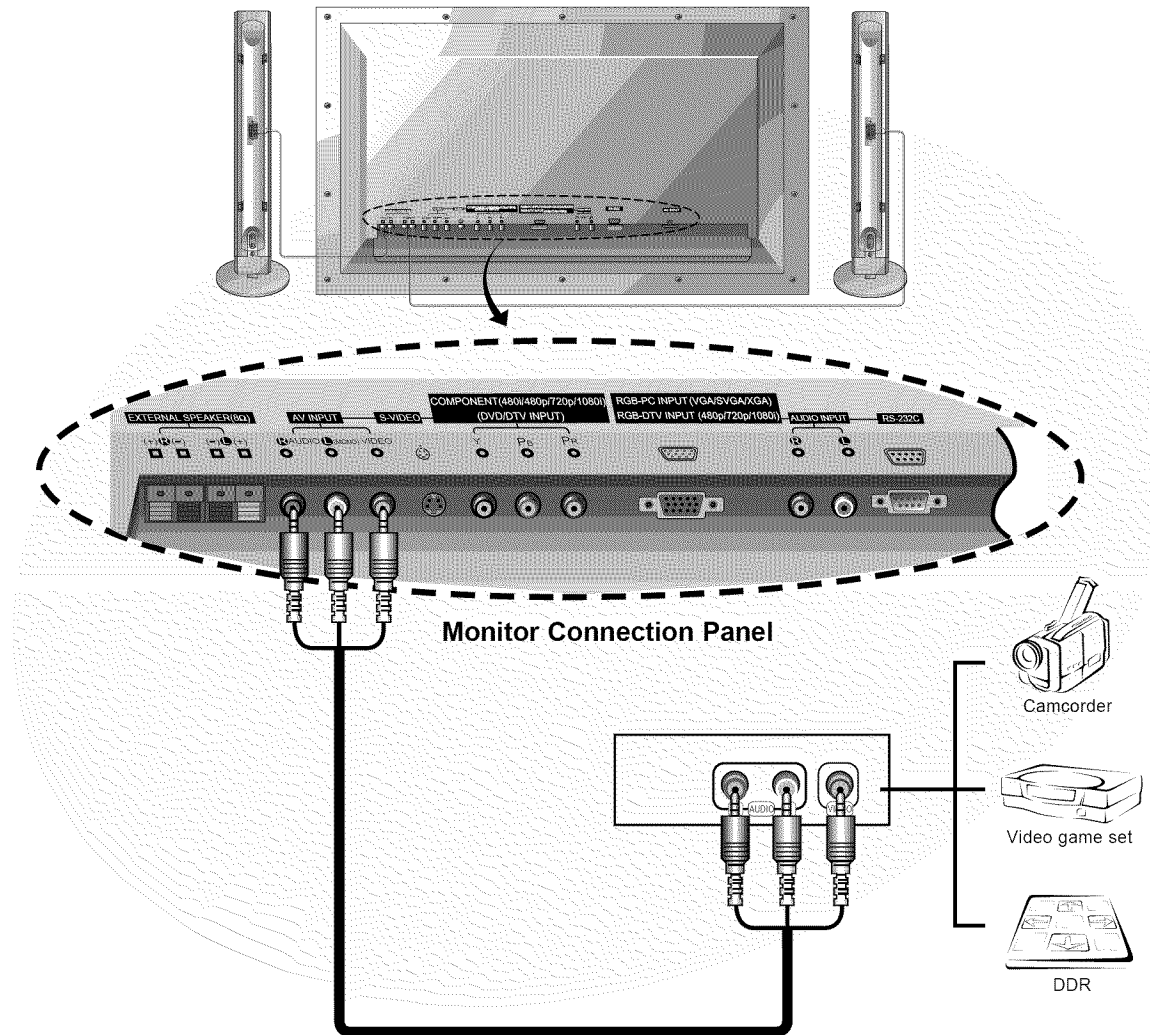

To watch external AV source

- 1 Use the **video/pc** button on the monitor's remote control or **INPUT SELECT** on the monitor to select the **VIDEO** source.
- 2 Operate the corresponding external equipment. See external equipment operating guide.



DVD Setup

How to connect a DVD (digital video disk player)

- Connect DVD video outputs to Y, P_B, P_R of COMPONENT (480i/480p/720p/1080i) (DVD/DTV INPUT) and audio inputs to Audio jacks of AV INPUT.

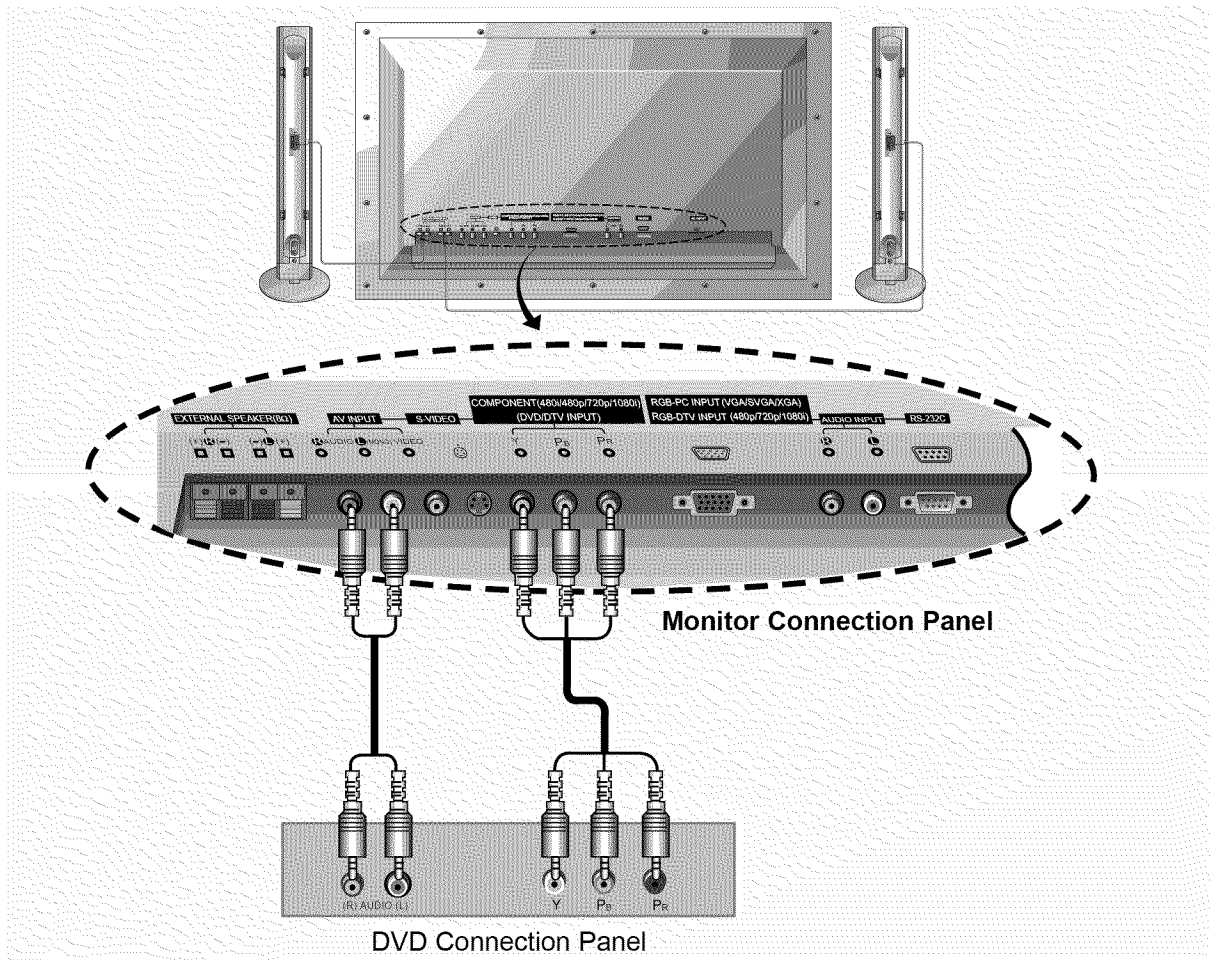

How to use

- Turn on the DVD player, and insert a DVD.
- Use the **video/pc** button on the monitor's remote control to select **COMPONENT**. See the DVD player's operating guide for operating instructions.

- **Component Input ports**
Connect DVD player jacks to Monitor Component input jacks as indicated below.

Component input jacks on the Monitor	Y	P _B	P _R
--------------------------------------	---	----------------	----------------

Video output jacks of DVD player	Y	P _b	P _r
	Y	B-Y	R-Y
	Y	Cb	Cr
	Y	P _B	P _R

DTV Setup

- To watch digitally broadcast programs, purchase/connect a digital SET-TOP BOX.
- You can only use the 16:9 picture format in DTV 720p/1080i mode.

How to connect a user-supplied Digital Set-top Box

- You can use either the Monitor's COMPONENT (Y, P_b, P_r) inputs or the single RGB-DTV INPUT for video connections, depending on your Set Top Box connectors. Then, make the corresponding Audio connections. See the diagram below for either setup.

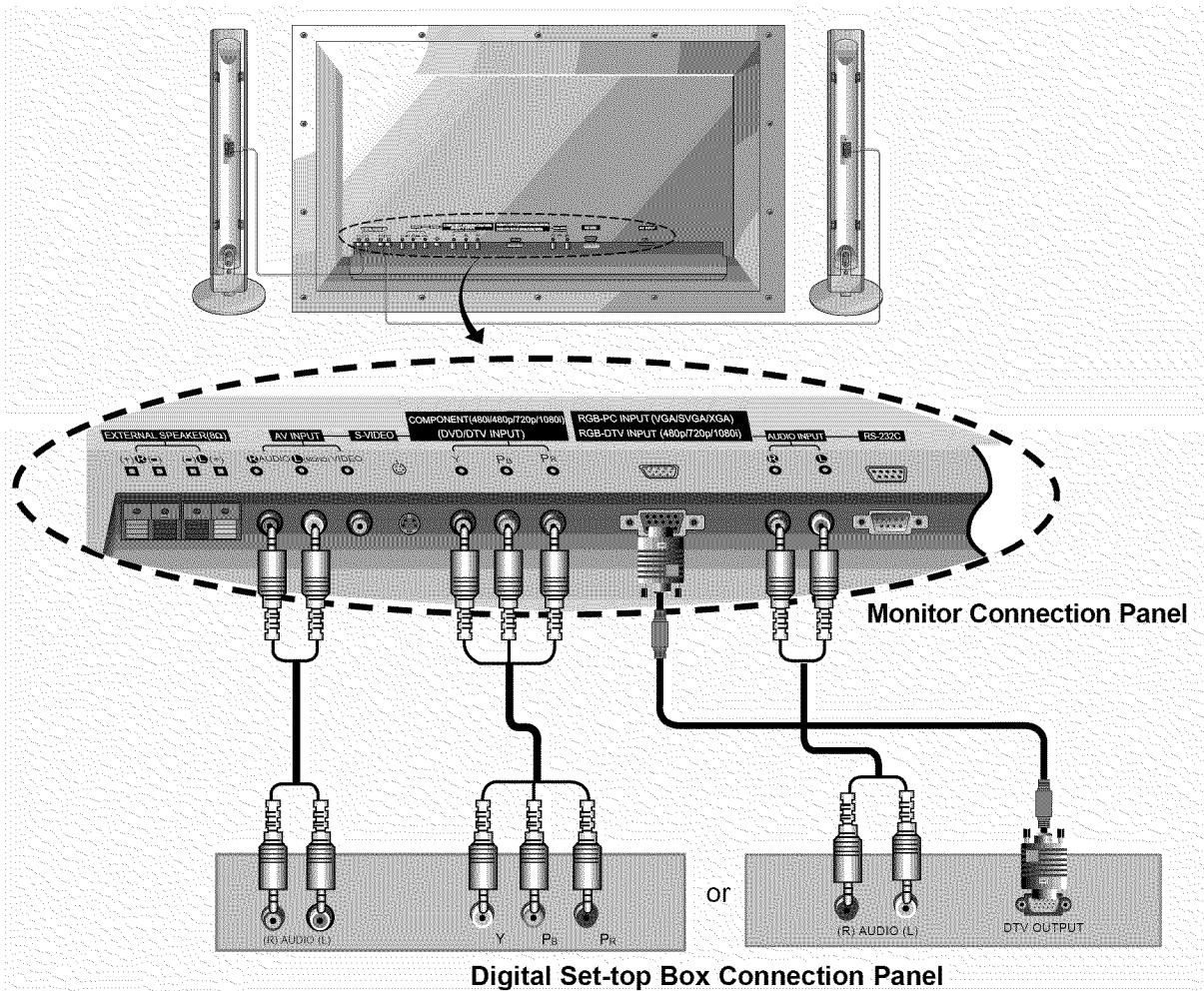

How to use

- Turn on the digital SET-TOP BOX, refer to the owner's manual.
- Use the **video/pc** button on the remote control to select **COMPONENT** or **RGB** source.

PC Setup

- Show your computer's image on the monitor.

How to connect

Make the connections shown in the illustration below.

- Set the computer video output to SXGA (1280x1024) or lower resolution. (If the video output of the PC is not compatible with the Monitor, no picture will appear on the Monitor. See page 21.)
- As shown below, connect the video output of the PC to the Monitor RGB-PC INPUT (VGA/SVGA/XGA) RGB-DTV INPUT (480p/720p/1080i).
- Connect the audio out from the PC to the Audio jacks on the Monitor. (Audio cables are not included with the Monitor)
- **If available, adjust PC sound to your preference.**
- To set up this monitor in a PC Windows environment, select Normal, Standard, or Default monitor. This monitor does not support Plug and Play function.

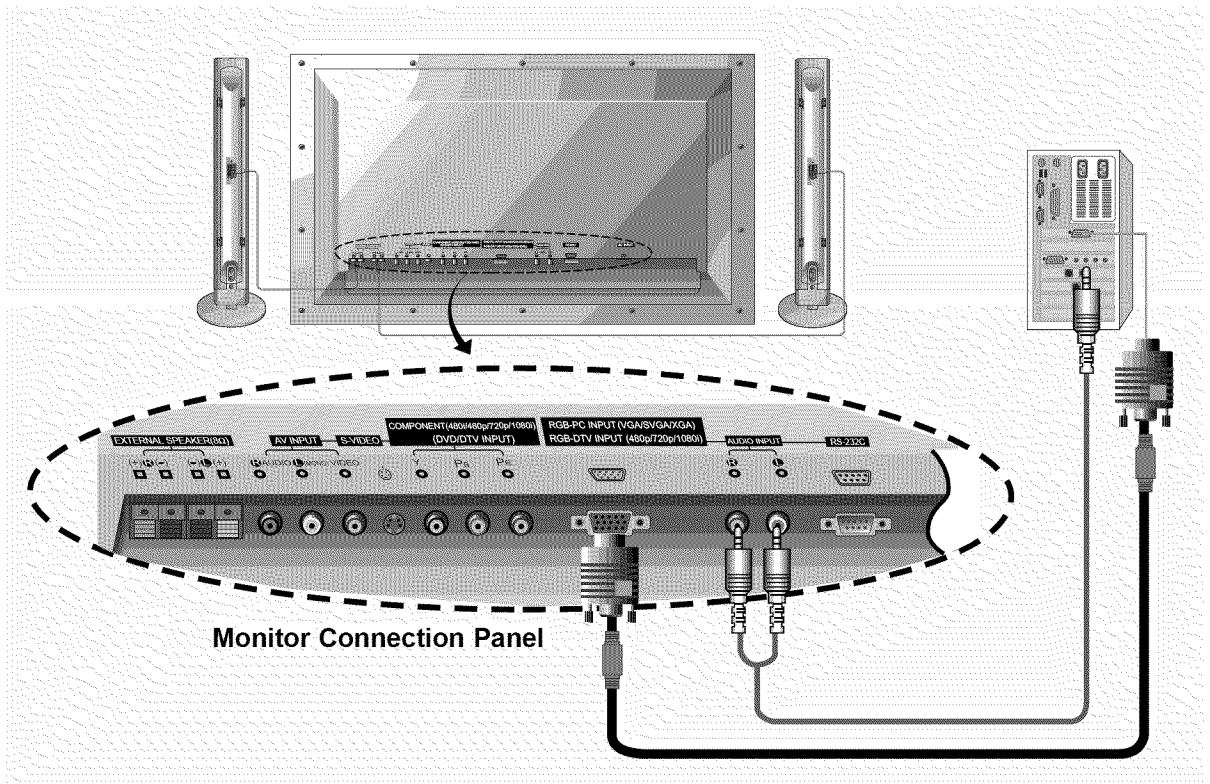

How to use



On the remote control

- Turn the PC on and press **ON/OFF** button on the Monitor, to go to standby mode. Then press **video/pc** button on the Monitor or press **power on** on the remote control.
- Use the **video/pc** button on the remote control to select the **RGB** source.
- Set the resolution output of the PC to XGA (1024x768) or lower. (Refer to page 21.)



Tip

- Avoid displaying a still or fixed image on the monitor screen for a long period of time. Doing so may imbed that image on the screen permanently.

Monitor Display Specifications

Resolution	Horizontal Frequency (KHz)	Vertical Frequency (Hz)
640x350	31.468	70.09
	37.861	85.08
640x400	31.469	70.08
	37.927	85.03
640x480	31.469	59.94
	35.000	66.66
	37.861	72.80
	37.500	75.00
	43.269	85.00
	45.913	90.03
	53.011	100.04
800x600	64.062	120.00
	35.156	56.25
	37.879	60.31
	48.077	72.18
	46.875	75.00
	53.674	85.06
	56.000	90.00
64.016	100.00	
832x624	49.725	74.55
852x480	34.660	70.00
1024x768	48.363	60.00
	56.476	70.06
	60.023	75.02
	68.677	84.99

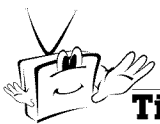

Tip

- Synchronization input form: Signals are separate.
- There might be a noise according to any resolution, contrast, or brightness in PC mode. Then change the PC mode into other resolution or adjust brightness and contrast on the menu until the picture is clean.

PC Mode Feature Check (Overview)

- Use video/pc on remote to select **RGB** mode.
- Make sure the PC and monitor are both turned on.
- Use the monitor's remote control to make adjustments.



1 Press the **menu** button to show a menu on screen.



2 Use the **up/down** button to select a menu.
• Each press will cycle through the different menus as shown below.

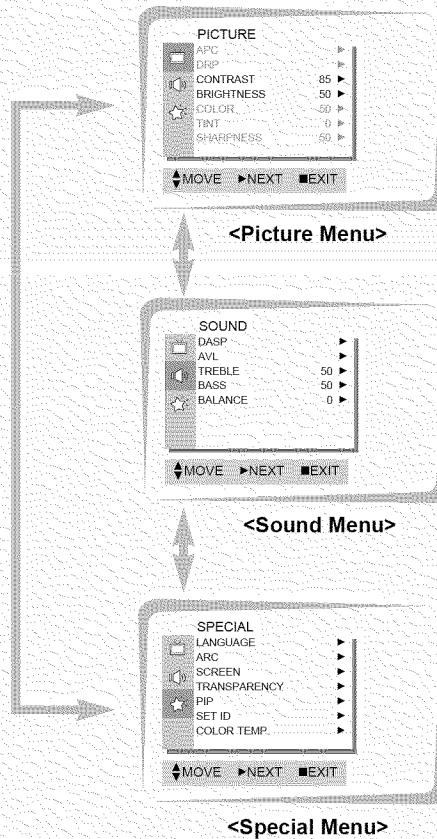

- The Color Temperature adjustment is only available on models P42W22B and P42W22H.



3 Press the **vol (▶)** button and then use the **up/down** or **vol** buttons to select a feature you want to use.
• Use the **enter** button to exit menus.

PC Mode Adjustments

Auto Adjustment

- Automatically adjusts picture position and minimizes image shaking.



Press the **menu** button and then use the **up/down** button to select the **SPECIAL** menu.
Press the **vol (▶)** button.

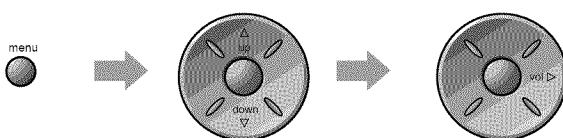

1 Use the **up/down** button to select **SCREEN** and then press the **vol (▶)** button.

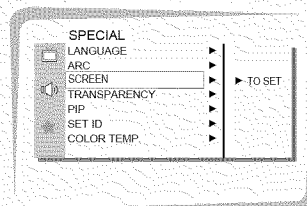
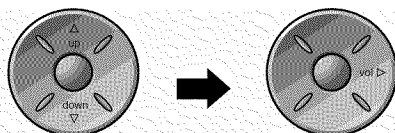

2 Use the **up/down** button to select the **AUTO.CONFIG.** option and then press the **vol (▶)** button.

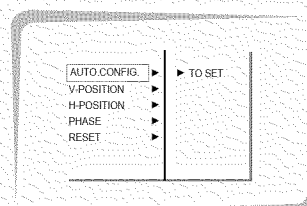
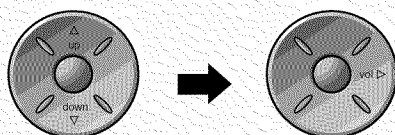

- When **AUTO.CONFIG.** has finished, "**OK**" will be shown on screen.
- If the position of the image is still not correct, try Auto adjustment again.

3 If picture needs to be adjusted more after Auto adjustment, you can manually adjust the image position and **PHASE**.



Tip

- If the image is still not correct, your Monitor is functioning properly but needs further adjustment.

PC Mode Adjustments

● Adjusting horizontal / vertical position manually

- Only adjust **V-POSITION** and **H-POSITION** in DTV or component 480p/720p/1080i.



Press the **menu** button and then use the **up/down** button to select the **SPECIAL** menu. Press the **vol (▶)** button.

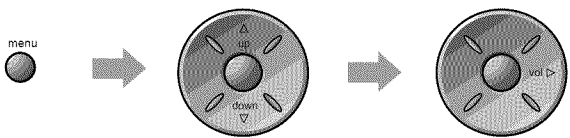

1 Use the **up/down** button to select **SCREEN** and then press the **vol (▶)** button.

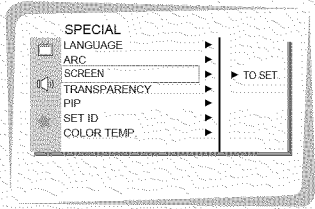
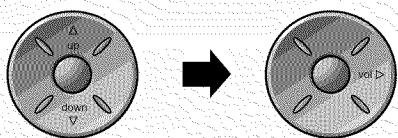

2 Use the **up/down** button to select **V-POSITION** or **H-POSITION** and then press the **vol (▶)** button.

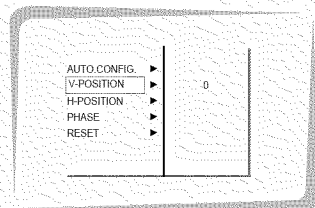
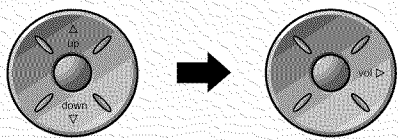

3 Use the **vol** buttons to adjust to get the desired horizontal or vertical position and then press the **enter** button to remove menus.

- The adjustment range of **V-POSITION** is -50 ~ +50.
- The adjustment range of **H-POSITION** is -100 ~ +100.
- Based on the input mode, the adjustment range of **V-POSITION/H-POSITION** may change.
- Based on the VGA card, the adjustment range of **V-POSITION/H-POSITION** may be out of -100 ~ +100 after auto configure.
- Based on the input signal, the position of the picture may not change even though you have adjusted the horizontal or vertical positions.

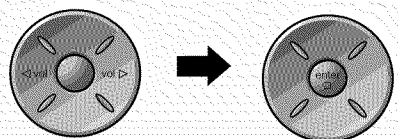

Picture Phase Adjustments

- If the picture isn't clear after auto adjustment and especially if the characters are still trembling, then adjust the picture phase manually.
- The **SCREEN** menu option will not be selectable if PIP is active.



Press the **menu** button and then use the **up/down** button to select the **SPECIAL** menu. Press the **vol (▶)** button.

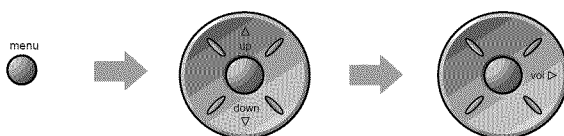

1

Use the **up/down** button to select **SCREEN** and then press the **vol (▶)** button.

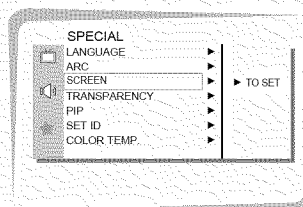
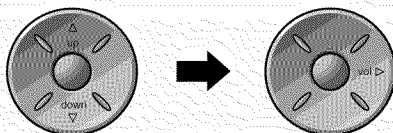

2

Use the **up/down** button to select **PHASE** and then press the **vol (▶)** button.

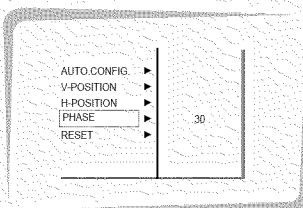
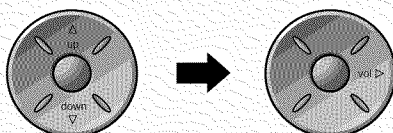

3

Use a **vol** button to adjust phase and then press the **enter** button.

- The adjustment range of **PHASE** is 0 ~ 63.

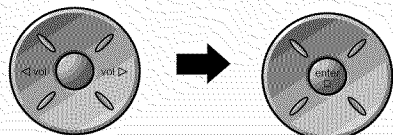

Initializing (Reset to factory value)

- To initialize the adjusted value, select **RESET** with the **▲ / ▼** button and then press the **▶** button.

Picture In Picture (PIP) function

- PIP lets you see 2 different inputs (sources) on your monitor screen at the same time. One source will be large, and the other source will show a smaller inset image.
- Select **RGB** input source before pressing PIP.
- PIP works in the following resolutions;
640x480, 800x600, 1024x768 (only in Vertical frequency 60 Hz)
- When you select RGB or DTV for main picture with PIP on, you can watch video, cable TV, or DVD source for sub picture.
- Color of main picture may be different from PIP's in PIP mode.
- If input source for main picture is changed while in PIP mode, sub picture will disappear.
- When watching PIP, **SCREEN** option is not selectable in Special menu.
- With PIP active, not all picture formats can be used for the main/sub picture.

● Watching PIP (Picture-In-Picture)



Press the **pip** button.

- Each time you press **pip** or **vol** button, you change the PIP picture size as shown below.

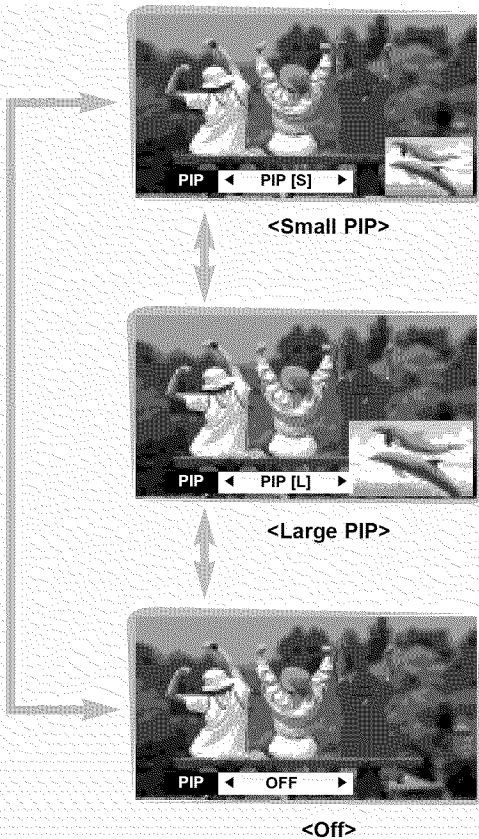
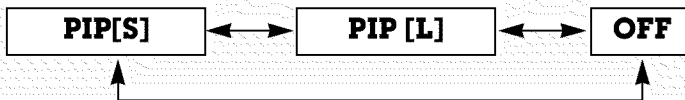

Selecting a source input signal

input select



Press the **input select** button repeatedly in PIP mode.

- Each time you press **input select** button, you toggle between **VIDEO**, **S-VIDEO** and **COMPONENT**.



COMPONENT source only works in 480i mode.

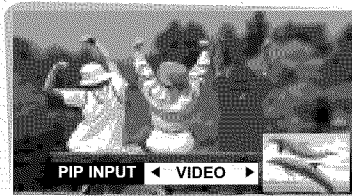

Moving the PIP (inset) picture

position



Press the **position** button in PIP mode.

- Each press of the **position** button will move the PIP picture on the screen as shown below.



Remote Control Setup

Installing batteries

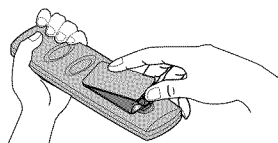

- Open the battery compartment cover on the back of the remote control and insert the batteries with correct polarity, match “+” with “+”, and match “-” with “-”.
- Install two 1.5V “AA” alkaline batteries. Don't mix used batteries with new batteries.

Notes for using the remote control

Make sure there are no objects between the remote control and its sensor.

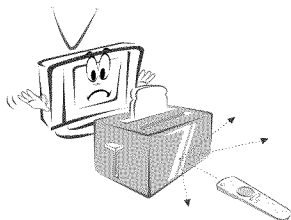

Don't place the remote control near a heater or damp place. Strong impact on the remote control may cause operation failure.

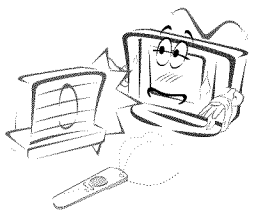

Signal from the remote control may be disturbed by sun light or other strong light. In this case, turn the set to other direction.



Turning on the Monitor

- When using the remote control, aim it at its sensor on the Monitor.

Turning on the Monitor just after installation

- 1 Plug power cord into power outlet correctly.
- 2 Press the main **ON/OFF** button on the Monitor. At this moment, the Monitor is switched to standby mode. Press the $\phi/1$ or **INPUT SELECT** button on the Monitor or press **power on** or **video/pc** button on the remote control to turn the Monitor on.

Turning on the Monitor (power cord is still connected)

- 1 **If the Monitor is turned off with the $\phi/1$ button on the Monitor**
Press the $\phi/1$ or **INPUT SELECT** button on the Monitor or press the **power on** or **video/pc** button on the remote control to turn the Monitor on.
- 2 **If the Monitor is turned off with the ON/OFF button on the Monitor**
 - Press the main **ON/OFF** button on the Monitor to turn the Monitor on.
- 3 **If the Monitor is turned off with the remote control and also the ON/OFF button on the Monitor**
 - Press the main **ON/OFF** button on the Monitor and then press the $\phi/1$ or **INPUT SELECT** button on the Monitor or press the **power on** or **video/pc** button on the remote control to turn the Monitor on.

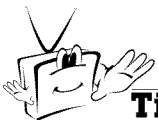

Tip

- **Adjusting sound level**
The volume (▶) button increases the sound level and the volume (◀) button decreases the sound level.

Menu Language Selection



Press the **menu** button and then use the **up/down** button to select the **SPECIAL** menu.
Press the **vol (▶)** button.

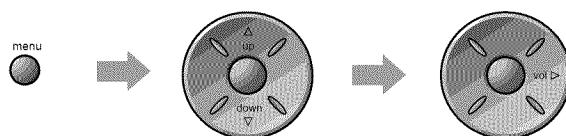

1

Use the **up/down** button to select **LANGUAGE** and then press the **vol (▶)** button.

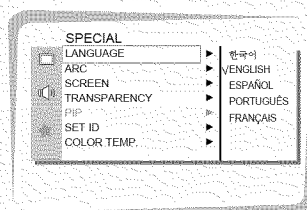
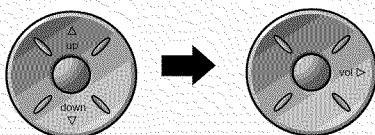

2

Use the **up/down** button to select the desired language.

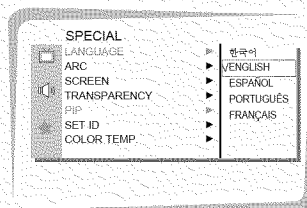
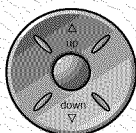

3

Press the **enter** button to exit.

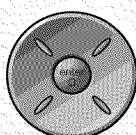

Checking Features

- Use the remote control to make adjustments.
- Select **VIDEO** input source

menu



1

Press the **menu** button.

2

Press the **up/down** button.

- Each press will cycle through the menus shown below.

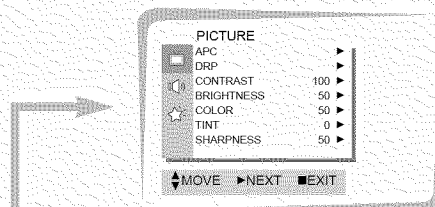
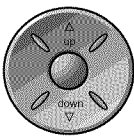

Picture Menu

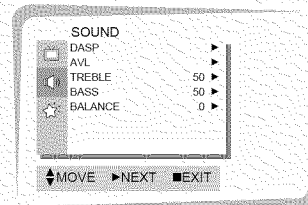

Sound Menu

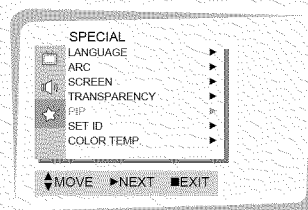

Special Menu

- The Color Temperature adjustment is only available on models P42W22B and P42W22H.

3

Use the **vol** (▶) button to select menu option to adjust, and then use the **up/down** or **vol** buttons to adjust the selected option.

- Press the **enter** button to exit.

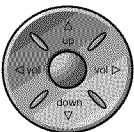

Setting Sleep Timer

Sleep Timer turns the Monitor after the preset time expires



Use the **sleep** button to set a sleep time. Each time you press the **sleep** button, the time setting time changes as follows:

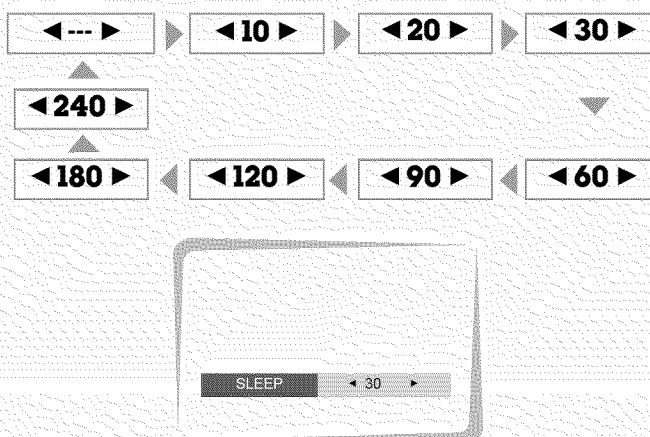

- To cancel sleep time setting, press the **sleep** or **</>** button repeatedly to select **<--->**.
- '⚠ **SLEEP 1**' will be displayed one minute before the Monitor is due to turn off.



Tips

- When the sleep time you want is displayed on the screen, don't press the **sleep** button. After 20 seconds, the screen display disappears and sleep time is set.
- To check remaining sleep time after setting, press the **sleep** or **enter** button just once.
- If you turn the Monitor off after setting the sleep timer, the setting is erased. The sleep timer will then have to be set again.

Auto Picture Control

Use APC to adjust the Monitor for the best picture appearance

- APC is not available in RGB or PIP mode.

● APC (Auto Picture Control)



1 Press the **apc** button.

2 Press the **apc** or **vol** buttons to select the picture appearance setup.

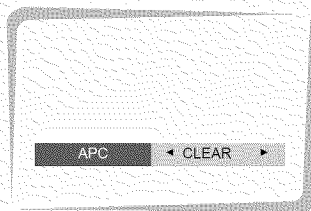

- Each press of **vol** buttons selects the menu option as shown below.



- You can also select **CLEAR**, **SOFT** or **USER** in the **PICTURE** menu. User refers to adjustments made to the picture menu options. See next page.

DRP (Digital Reality Picture)

DRP improves image outlines in dark screens.

- This feature works in both video and component 480i modes.



Press the **menu** button and use press the **up/down** button to select the **PICTURE** menu.
Press the **vol (▶)** button.

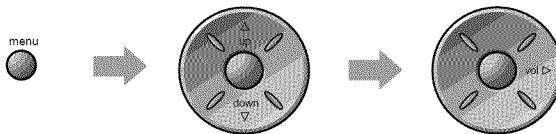

1

Use the **up/down** button to select **DRP** and then press the **vol (▶)** button.

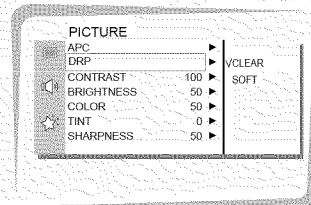
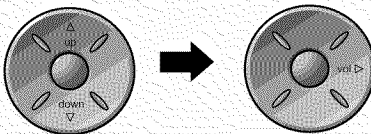

2

Use the **up/down** button to select **CLEAR** or **SOFT**.

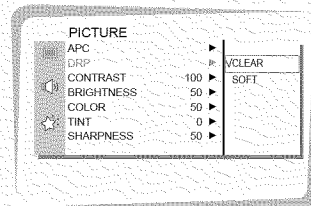
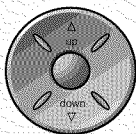

3

Press the **enter** button to exit.

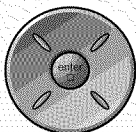

Adjusting Sound

Manual setting



Press the **menu** button and then use the **up/down** button to select the **SOUND** menu.
Press the **vol** (▶) button.

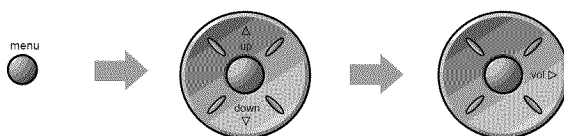

1

Example Adjustment: Treble
Use the **up/down** buttons to select **TREBLE** and then press the **vol** (▶) button.

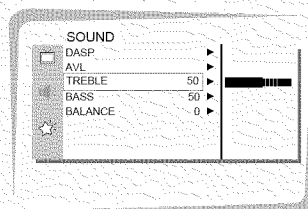
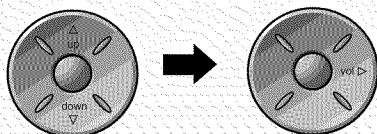

2

Use the **vol** buttons to make appropriate adjustments and then press the **enter** button to exit.

- Use the **up/down** buttons to select other options.

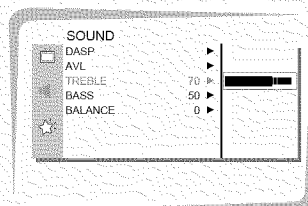
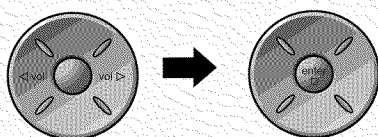

- Adjust **BASS** and **BALANCE** in the same way.

Auto Sound Control

DASP (Digital Auto Sound Processing)

- This feature lets you enjoy the best sound without any manual adjustment. The Monitor automatically selects the appropriate audio tone levels based on the program content.

easy sound



1

Press the **easy sound** button.

2

Use the **easy sound** or **vol** buttons to select a sound setup.

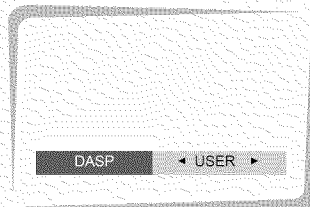

- Each press of **easy sound** or **vol** buttons changes menu option as shown below.

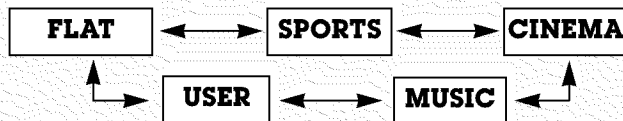

- You can also select **FLAT**, **SPORTS**, **CINEMA**, **MUSIC** or **USER** in the **SOUND** menu.

AVL (Auto Volume Leveler)

AVL maintains a consistent volume level; even if you change channels.



Press the **menu** button and then use the **up/down** button to select the **SOUND** menu. Press the **vol (▶)** button.

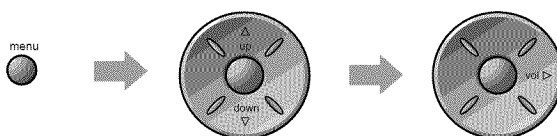

1

Use the **up/down** button to select **AVL** and then press the **vol (▶)** button.

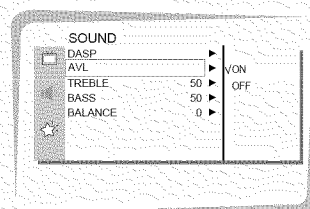
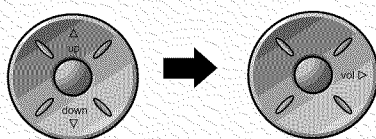

2

Use the **up/down** button to select **ON** or **OFF**.

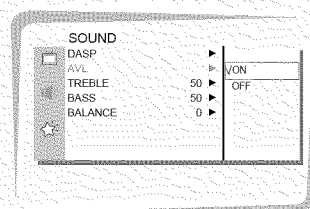
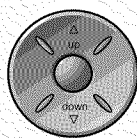

3

Press the **enter** button to exit.

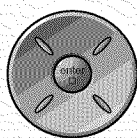

Using Still function

- This feature isn't available for RGB input source.
- Use with the A/V or COMPONENT video input sources.



1

Press the **freeze** button.

- The image displayed is frozen (stilled).
- The sub picture is stilled in PIP mode.
- In PIP mode, the sub (inset) picture is frozen.



Moving Image

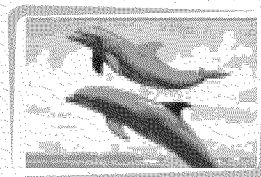

Still (frozen) Image

2

To return to normal viewing, press the **freeze** button again.

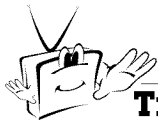

Tip

- If a still picture is on the screen for more than 5 minutes, the image darkens. This is a protective feature designed to lessen the chance of a ghost image burning onto the monitor screen. If another function is activated, normal screen brightness is restored.
- This is a protective feature designed to reduce a ghost image burning into the monitor.

Using the screen options

- This function is for video mode.
- Use this option to correct trembling or instability of a videotape image.



Press the **menu** button and use press the **up/down** button to select the **SPECIAL** menu.
Press the **vol (▶)** button.

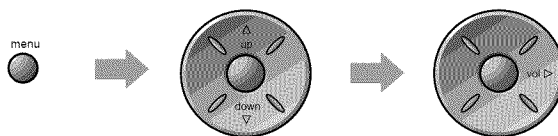

1

Use the **up/down** button to select **SCREEN** and then press the **vol (▶)** button.

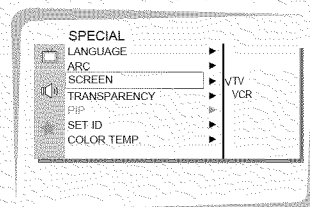
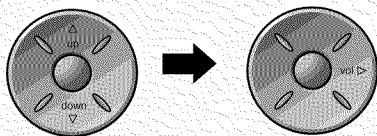

2

Use the **up/down** buttons to select **TV** or **VCR**.

- Select the **VCR** option if watching a VCR.
- Select the **TV** option for other equipment. (Except VCR)
- Each time you press the **▲ / ▼** button you toggle between **TV** and **VCR**.

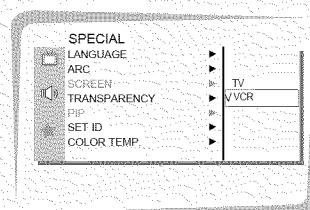
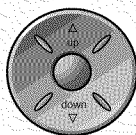

3

Press the **enter** button to remove menu from screen.

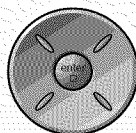

Adjusting OSD Transparency

Makes the menu backgrounds clear or opaque



Press the **menu** button and then use the **up/down** button to select the **SPECIAL** menu.
Press the **vol (▶)** button.

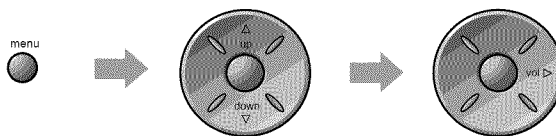

1

Use the **up/down** button to select **TRANSPARENCY** and then press the **vol (▶)** button.

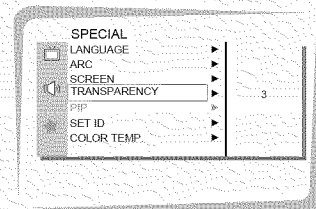
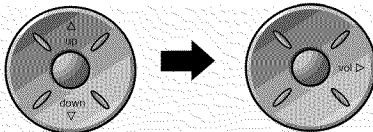

2

Use the **vol** buttons to adjust OSD transparency.

- The **TRANSPARENCY** adjustment range is 1 ~ 4.

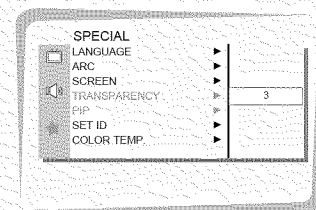
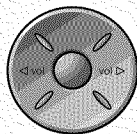

3

Press the **enter** button to remove menu from screen.

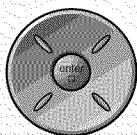

Color Temperature Adjustments

- Color Temperature adjustments are only available on models P42W22B and P42W22H.
- Adjustments also affect the color temperature of other input sources. Readjust color temperature for PC input (RGB) if necessary.
- To restore factory settings, select '0' in **RED**, **GREEN**, and **BLUE**.



Press the **menu** button and then press the **up/down** button to select the **SPECIAL** menu. Press the **vol (▶)** button.

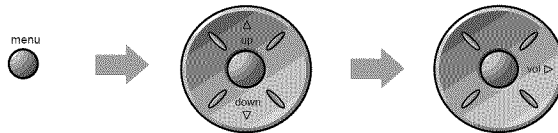

1

Press the **up/down** button to select **COLOR TEMP.** and then press the **vol (▶)** button.

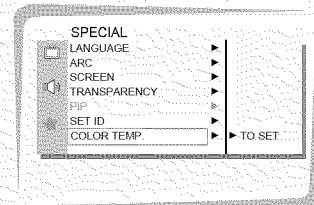
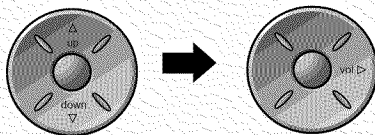

2

Press the **up/down** button to select **RED** and then press the **vol (▶)** button. (to adjust RED setting)

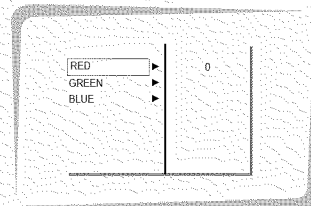
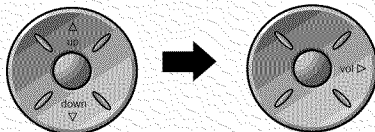

- Adjust **GREEN** and **BLUE** in the same way.

3

Use the **vol** button to make appropriate adjustments and then press the **enter** button.

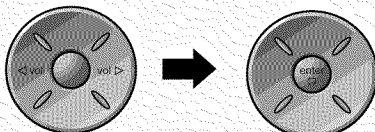

- The adjustment range of **RED**, **GREEN** and **BLUE** is -5 ~ +5.

Setting Picture Format

- For the RGB-PC source, you can select either 16:9 or 4:3 screen aspect ratios.
- You are only available the 16:9 screen aspect ratio in RGB-DTV (720p, 1080i) source.
- You are only available the 16:9 screen aspect ratio in RGB-PC (852x480) source.
- If 4:3 mode is used for a long time, the outline of the image may remain on the screen after you change to the 16:9 screen aspect ratio.
- Don't display 4:3 picture format continuously for more than 10 hours.



Use the **ratio** button to select the desired picture format.

- Each time you press **ratio** or **vol** buttons, you cycle through **16:9**, **4:3**, and **ZOOM**.

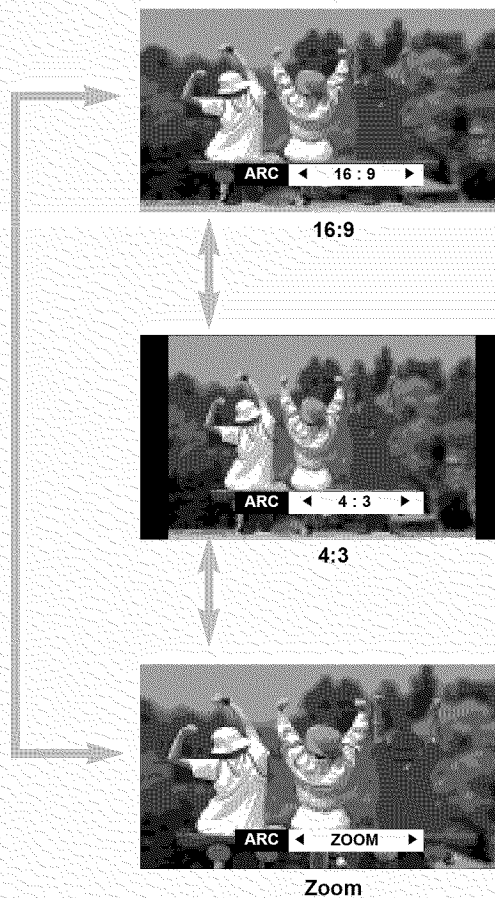

- You can also select the **16:9**, **4:3**, or **ZOOM** option using the **SPECIAL** menu.

External Control Device Setup

- Connect the RS-232C input jack to an external control device (such as a computer or an A/V control system) and control the Monitor's functions externally.

How to connect external control equipment

- Connect the serial port of the control device to the RS-232C jack on the Monitor back panel.
- RS-232C connection cables are not supplied with the Monitor.
- The Monitor remote control and front panel controls (except main power) will not be functional if the Monitor is controlled by a PC computer or other external device.

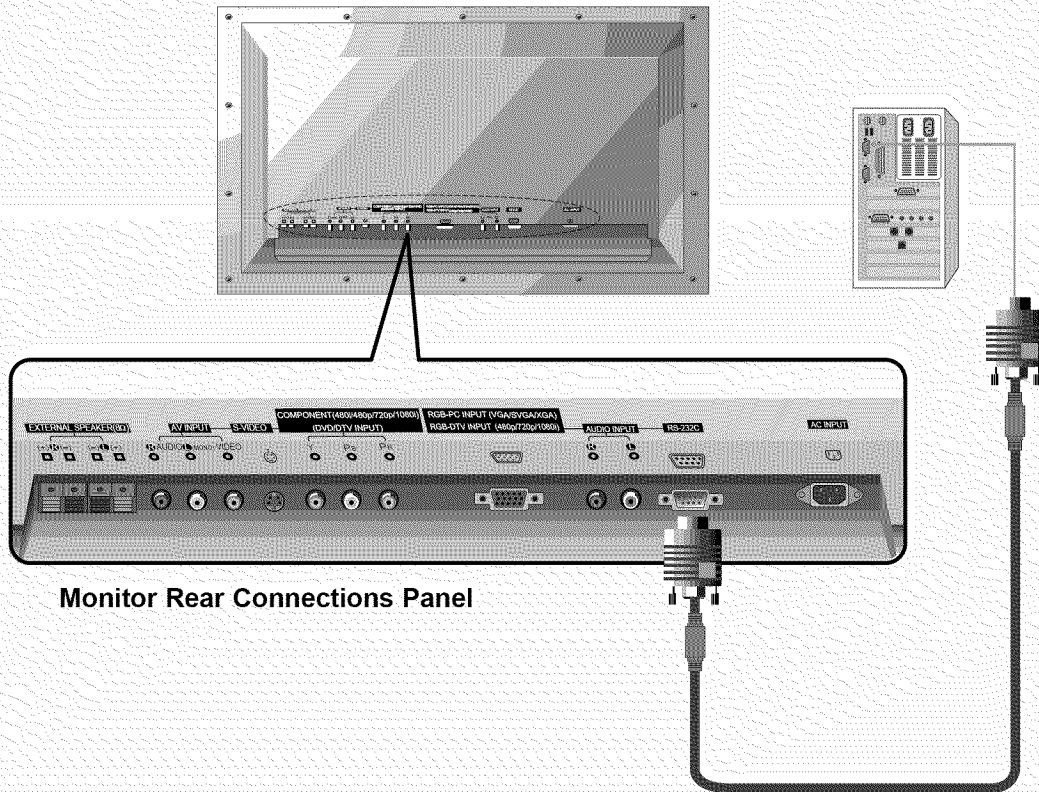

External Control Device Setup

Type of connector : D-Sub 9-pin male

No.	Pin name
1	No connection
2	RXD (Receive data)
3	TXD (Transmit data)
4	DTR (DTE side ready)
5	GND
6	DSR (DCE side ready)
7	RTS (Ready to send)
8	CTS (Clear to send)
9	No Connection

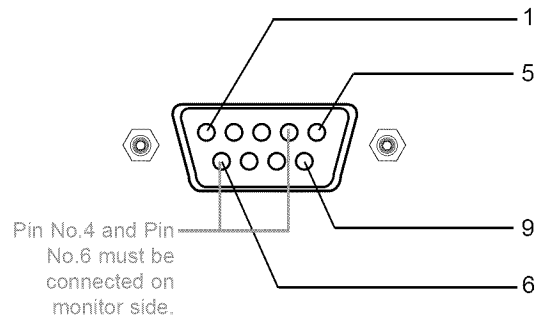

- * Use a null modem cable.

Wire the 7-Wire cable so that each pair of data lines cross between the two devices. These data line pairs are RXD (Receive data) and TXD (Transmit data), DTR (DTE side ready) and DSR (DCE side ready), and RTS (Ready to send) and CTS (Clear to send).

When using the 3-Wire cable connected to RXD, TXD and GND; Pin No. 4 (DTR) and Pin No. 6 (DSR) must be connected to the monitor. (The cable must be disconnected from the Monitor to be able to use the remote control and Monitor front panel controls.)

- * With the RS-232 input connected, the Monitor cannot be controlled by both an external control device and the remote control at the same time. The Monitor can only be controlled by either the remote control or the external control device.

RS-232C configurations

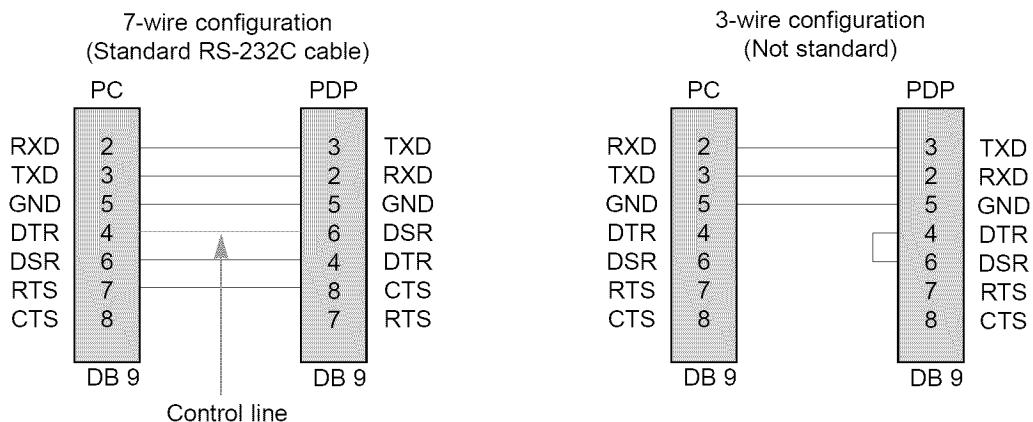

7-Wire Cable Configuration

- The Monitor is available to switch between external adjustment and remote control adjustment using a control line.

Note: If the control line is high, the monitor is controlled by the external control device. If the control line is low, the Monitor is controlled by the Monitor's remote control.

3-Wire Cable Configuration

- When using a 3-Wire cable configuration there is no control line. The external control device must put the Monitor into the "change into remote control adjustment mode" (see page 52). The Monitor will then be able to be controlled by the remote control. If the Monitor is turned back on, it will revert back to external device control.

SET ID

- Once SET ID is selected, use the vol button to choose a monitor ID number.



Press the **menu** button and then use the **up/down** button to select the **SPECIAL** menu.
Press the **vol** (▶) button.

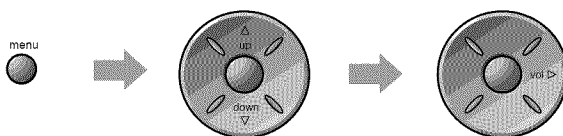

- Use the **up/down** buttons to select **SET ID** and then press the **vol** (▶) button.

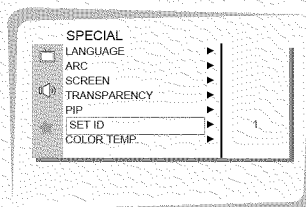
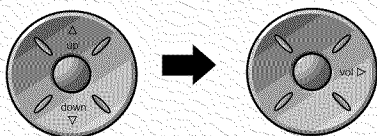

- Use the **vol** button to adjust **SET ID** to choose a desired monitor ID number.

- The adjustment range for **SET ID** is 1 ~ 99.

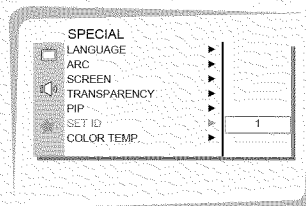
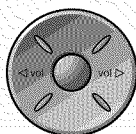

External Control Device Setup

- The RS-232C input jack is used to control the Monitor's functions using an external control device.

Communication Parameters

- Baud rate : 2400 bps (UART)
- Data length : 8 bits
- Parity : None
- Stop bit : 1 bit
- Communication code : ASCII code

* If the command interval is interrupted for more than 4 seconds, only Command 1 will be recognized.
Be careful when using the power command.

Command Reference List

NAME	COMMAND	DATA RANGE
01. Power	p	0 ~ 1
02. Input Select	i	0 ~ 3
03. Aspect Ratio	r	0 ~ 2
04. Screen mute	m	0 ~ 1
05. Volume mute	w	0 ~ 1
06. Volume control	v	0 ~ 64
07. Contrast	k	0 ~ 64
08. Brightness	b	0 ~ 64
09. Color	c	0 ~ 64
10. Tint	t	0 ~ 64
11. Sharpness	s	0 ~ 64
12. OSD select	d	0 ~ 1
13. Abnormal state	a	0 ~ 1
14. PIP	z	0 ~ 3
15. PIP input select	e	0 ~ 1
16. PIP sound select	u	0 ~ 1
17. PIP position	x	0 ~ 3
18. remote control adjustment mode	j	0 ~ 1

Transmission / Receiving Protocol

Transmission

[Command][][Set ID][][Data][Cr]

- * [Command] : To control PDP set.
- * [Set ID] : You can adjust the set ID to choose desired monitor ID number in special menu. See page 47. Adjustment range is 1 ~ 99.
When selecting Set ID '0', every connected PDP set is controlled.
- * [DATA] : To transmit command data.
Transmit 'FF' data to read status of command.
- * [Cr] : Carriage Return
ASCII code '0x0D'
- * [] : ASCII code 'space (0x20)'

OK Acknowledgement

[Set ID]::[OK][x][Data][x]

- * The Monitor transmits ACK (acknowledgement) based on this format when receiving normal data. At this time, if the data is data read mode, it indicates present status data. If the data is data write mode, it returns the data of the PC computer.

Error Acknowledgement

[Set ID]::[NG][x]

- * The Monitor transmits ACK (acknowledgement) based on this format when receiving abnormal data from non-viable functions or communication errors.

01. Power (Command:p)

- ▶ To control Power On/Off of the Monitor.

Transmission

```
[p][ ][Set ID][ ][Data][Cr]
```

Data 0 : Power Off
1 : Power On

- * Example : Power on for set ID No.3.
Type : P 3 1 '0x0D'

Acknowledgement

```
[Set ID]::[OK][x][Data][x]
```

Data 0 : Power Off
1 : Power On

- * In example : Monitor Acknowledges power on for set ID No.3.

- ▶ To show Power On/Off.

Transmission

```
[p][ ][Set ID][ ][FF][Cr]
```

Acknowledgement

```
[Set ID]::[OK][x][Data][x]
```

Data 0 : Power Off
1 : Power On (RGB)
2 : Power On (Video)
3 : Power On (Component)
4 : Power On (S-Video)

- * In like manner, if other functions transmit 'FF' data based on this format, Acknowledgement data feed back presents status about each function.

02. Input select (Command:i)

- ▶ To select input source for the Monitor.
You can also select an input source using the video/pc button on the Monitor's remote control.

Transmission

```
[i][ ][Set ID][ ][Data][Cr]
```

Data 0 : RGB
1 : AV (Video)
2 : Component
3 : S-AV (S-Video)

Acknowledgement

```
[Set ID]::[OK][x][Data][x]
```

Data 0 : RGB
1 : AV (Video)
2 : Component
3 : S-AV (S-Video)

03. Aspect Ratio (Command:r)

- ▶ To adjust the screen format.
You can also adjust the screen format using the ratio (Aspect Ratio Control) button on remote control or in the Special menu.

Transmission

```
[r][ ][Set ID][ ][Data][Cr]
```

Data 0 : Wide screen (16:9)
1 : Normal screen (4:3)
2 : Full screen (Zoom)

Acknowledgement

```
[Set ID]::[OK][x][Data][x]
```

Data 0 : Wide screen (16:9)
1 : Normal screen (4:3)
2 : Full screen (Zoom)

- * Using the PC input, you select either 16:9 or 4:3 screen aspect ratio.

- * Using the DTV 720p/1080i input, you can only select 16:9 screen aspect ratio.

04. Screen mute (Command:m)

- ▶ To select screen mute on/off.

Transmission

```
[m][ ][Set ID][ ][Data][Cr]
```

Data 0 : Screen mute on (Picture off)
1 : Screen mute off (Picture on)

Acknowledgement

```
[Set ID]::[OK][x][Data][x]
```

Data 0 : Screen mute on (Picture off)
1 : Screen mute off (Picture on)

05. Volume mute (Command:w)

- ▶ To control volume mute on/off.
You can also adjust mute using the mute button on remote control.

Transmission

```
[w][ ][Set ID][ ][Data][Cr]
```

Data 0 : Volume mute on (Volume off)
1 : Volume mute off (Volume on)

Acknowledgement

```
[Set ID]::[OK][x][Data][x]
```

Data 0 : Volume mute on (Volume off)
1 : Volume mute off (Volume on)

External Control Device Setup

06. Volume control (Command:v)

- ▶ To adjust volume.
You can also adjust volume with the volume buttons on remote control.

Transmission

[v][][Set ID][][Data][Cr]

Data Min : 0 ~ Max : 64

* Refer to 'Real data mapping' as shown below.

Acknowledgement

[Set ID]::[OK][x][Data][x]

Data Min : 0 ~ Max : 64

07. Contrast (Command:k)

- ▶ To adjust screen contrast.
You can also adjust contrast in the Picture menu.

Transmission

[k][][Set ID][][Data][Cr]

Data Min : 0 ~ Max : 64

* Refer to 'Real data mapping' as shown below.

Acknowledgement

[Set ID]::[OK][x][Data][x]

Data Min : 0 ~ Max : 64

08. Brightness (Command:b)

- ▶ To adjust screen brightness.
You can also adjust brightness in the Picture menu.

Transmission

[b][][Set ID][][Data][Cr]

Data Min : 0 ~ Max : 64

* Refer to 'Real data mapping' as shown below.

Acknowledgement

[Set ID]::[OK][x][Data][x]

Data Min : 0 ~ Max : 64

09. Color (Command:c)

- ▶ To adjust the screen color.
You can also adjust color in the Picture menu.

Transmission

[c][][Set ID][][Data][Cr]

Data Min : 0 ~ Max : 64

* Refer to 'Real data mapping' as shown below.

Acknowledgement

[Set ID]::[OK][x][Data][x]

Data Min : 0 ~ Max : 64

10. Tint (Command:t)

- ▶ To adjust the screen tint.
You can also adjust tint in the Picture menu

Transmission

[t][][Set ID][][Data][Cr]

Data Red : 0 ~ Green : 64

* Refer to 'Real data mapping' as shown below.

Acknowledgement

[Set ID]::[OK][x][Data][x]

Data Red : 0 ~ Green : 64

11. Sharpness (Command:s)

- ▶ To adjust the screen sharpness.
You can also adjust sharpness in the Picture menu

Transmission

[s][][Set ID][][Data][Cr]

Data Min : 0 ~ Max : 64

* Refer to 'Real data mapping' as shown below.

Acknowledgement

[Set ID]::[OK][x][Data][x]

Data Min : 0 ~ Max : 64

* Real data mapping

0 : Step 0

⋮

A : Step 10

⋮

F : Step 15

10 : Step 16

⋮

64 : Step 100

12. OSD select (Command:d)

- ▶ To select OSD (On Screen Display) on/off.

Transmission

```
[d][ ][Set ID][ ][Data][Cr]
```

Data 0 : OSD off
1 : OSD on

Acknowledgement

```
[Set ID][:][OK][x][Data][x]
```

Data 0 : OSD off
1 : OSD on

- * The remote control and Monitor front panel controls (except main power) are not operable when the Monitor is set up to be controlled by the PC computer.

13. Abnormal state (Command:a)

- ▶ To recognize an abnormal state.

Transmission

```
[a][ ][Set ID][ ][FF][Cr]
```

Acknowledgement

```
[Set ID][:][OK][x][Data][x]
```

Data 0 : OK
1 : Fan alarm
2 : 5V down
3 : AC down

- * This function is "read only".

14. PIP (Command:z)

- ▶ To control PIP (Picture-in-Picture). You can also control PIP using the pip button on remote control or in the Special menu.

Transmission

```
[z][ ][Set ID][ ][Data][Cr]
```

Data 0 : PIP off
1 : PIP (small)
2 : PIP (large)

Acknowledgement

```
[Set ID][:][OK][x][Data][x]
```

Data 0 : PIP off
1 : PIP (small)
2 : PIP (large)

- * PIP only works in the following resolutions:
RGB PC 640x480 (VGA) / 800x600(SVGA) / 1024x768 (XGA) (only in vertical frequency 60Hz),
Component 480p / 720p / 1080i.

15. PIP input select (Command:e)

- ▶ To select input source for sub picture in PIP mode. You can also select source using input select button on the remote control or in the Special menu.

Transmission

```
[e][ ][Set ID][ ][Data][Cr]
```

Data 0 : AV (VIDEO)
1 : COMPONENT
2 : S-AV (S-VIDEO)

Acknowledgement

```
[Set ID][:][OK][x][Data][x]
```

Data 0 : AV (VIDEO)
1 : COMPONENT
2 : S-AV (S-VIDEO)

- * COMPONENT source only works with 480i input signal.

External Control Device Setup

16. PIP sound select (Command:u)

- ▶ To select main or sub (inset) sound for PIP. You can also select sound select in PIP on the special menu.

Transmission

[u][][Set ID][][Data][Cr]

Data 0 : Main picture sound
1 : Sub picture sound

Acknowledgement

[Set ID]::[OK][x][Data][x]

Data 0 : Main picture sound
1 : Sub picture sound

- * COMPONENT source only works in 480i input signal.

18. Change into Remote control adjustment mode (Command:j)

- ▶ To control the Monitor with the remote control while the cable is still connected.

Transmission

[j][][Set ID][][Data][Cr]

Data 1 : Remote control adjustment mode

Acknowledgement

[Set ID]::[OK][x][Data][x]

Data 0 : PC adjustment mode
1 : Remote control adjustment mode

- * If external equipment commands the Monitor to "change into remote control adjustment mode", the Monitor can only be adjusted by the remote control. To revert the Monitor control to external control device adjustment, turn the Monitor off and then on again.

17. PIP position (Command:x)

- ▶ To select sub picture position for PIP. You can also adjust the sub picture position using the position button on the remote control or in PIP on the Special menu.

Transmission

[x][][Set ID][][Data][Cr]

Data 0 : Right down on screen
1 : Left down on screen
2 : Left up on screen
3 : Right up on screen

Acknowledgement

[Set ID]::[OK][x][Data][x]

Data 0 : Right down on screen
1 : Left down on screen
2 : Left up on screen
3 : Right up on screen

Maintenance

- Early malfunctions can be prevented. Careful and regular cleaning can extend the amount of time you will have your new Monitor. Be sure to turn the power off and unplug the power cord before you begin any cleaning.

Cleaning the screen

1. Here's a great way to keep the dust off your screen for a while. Wet a soft cloth in a mixture of lukewarm water and a little fabric softener or dish washing detergent. Wring the cloth until it's almost dry, and then use it to wipe the screen.
2. Make sure the excess water is off the screen, and then let it air-dry before you turn on your Monitor.

Cleaning the cabinet

To remove dirt or dust, wipe the cabinet with a soft, dry, lint-free cloth. Please be sure not to use a wet cloth.

Extended absence



If you plan on leaving your Monitor dormant for a long time (such as a vacation), it's a good idea to unplug the power cord to protect against possible damage from lightning or power surges.



Troubleshooting Checklist

No picture & No sound

- Check whether the Monitor is turned on.
- Power cord inserted into wall power outlet?
- Plug another product's power cord into the wall outlet where the Monitor's power cord was plugged in to test outlet.

Picture OK & No sound

- Press the **VOLUME** (▶) button.
- Sound muted? Press **MUTE** button.

The remote control doesn't work

- Check to see if there is any object between the Plasma Display and the remote control causing obstruction.
- Check to see if the batteries are installed with the correct polarities. (Refer to p.29)
- Install new batteries. (Refer to p.29)

No or Poor color or Poor picture

- Select **COLOR** in the **PICTURE** menu and press the **VOLUME** (▶) button. (Refer to p.35)
- Increase the distance between the Monitor and the VCR.
- Activate any function to restore the brightness of the picture. (If still picture is on the screen for more than 5 minutes, the screen gets dark.)

No output from one of the speakers

- Adjust **BALANCE** in the **SOUND** menu. (Refer to p.37)
- Is speaker connected?

Product Specifications

MODEL	P42W22, P42W22B, P42W22H
Width (inches / mm)	41.6 / 1056
Height (inches / mm)	25 / 635
Depth (inches / mm)	3.2 / 82
Weight (pounds / kg)	72.1 / 32.7
Power requirement	120V, 60Hz
Resolution	852 x 480 (Dot)
Color	16,770,000 (256 steps of each R, G and B)

- The specifications shown above may be changed without prior notice for quality improvement.

P/NO : 3828VA0296L ①
(NF01DC)

206-03788