

Kenmore

SEWING MACHINE MODEL 17921



OWNER'S
MANUAL

55079

Sears, Roebuck and Co.

Dear Homemaker :

You have just invested in a very fine zigzag sewing machine. Before using your new Kenmore machine, please pause for a moment and carefully read this booklet which contains instructions on how to operate and care for your machine.

Specific instructions are given on threading, tension adjustments, cleaning, oiling, etc. This will help you obtain the best sewing results and avoid unnecessary service expense for conditions beyond our control.

Advice on the operation and care of your machine is always available at your nearest Sears Retail Store. Please remember, if you have questions about your machine, always mention the model number and serial number when you inquire.

Kenmore Sewing Machine

Record in space provided below the model number and serial number of this appliance.

The model number and serial number are located on the nomenclature plate, as identified on Page 3 of this booklet.

Model No. _____ Serial No. _____

Retain these numbers for future reference.

YOUR SEWING PLACE IS ALWAYS READY WITH SEARS KENMORE SEWING FURNITURE

Sewing machine cabinet is available at your nearest Sears retail store or through our general catalog. Whenever you're ready to sew, so is your sewing place. Another option... buy a Carrying Case... then your Kenmore goes anywhere, can be stored anywhere.

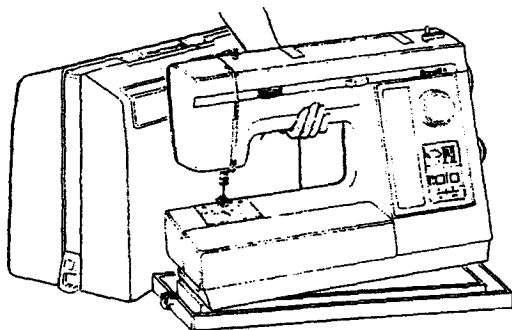
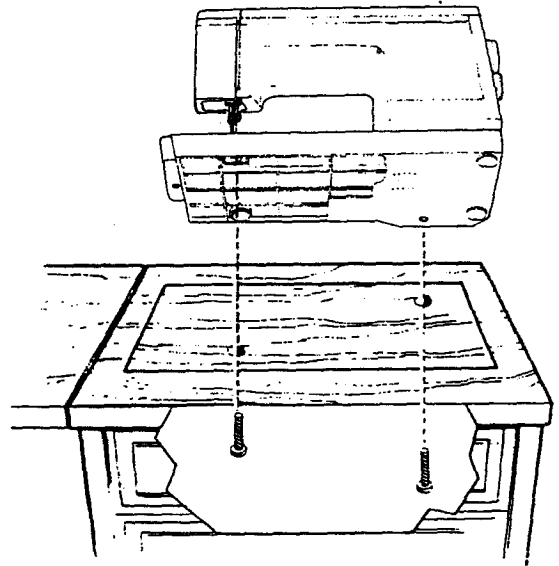
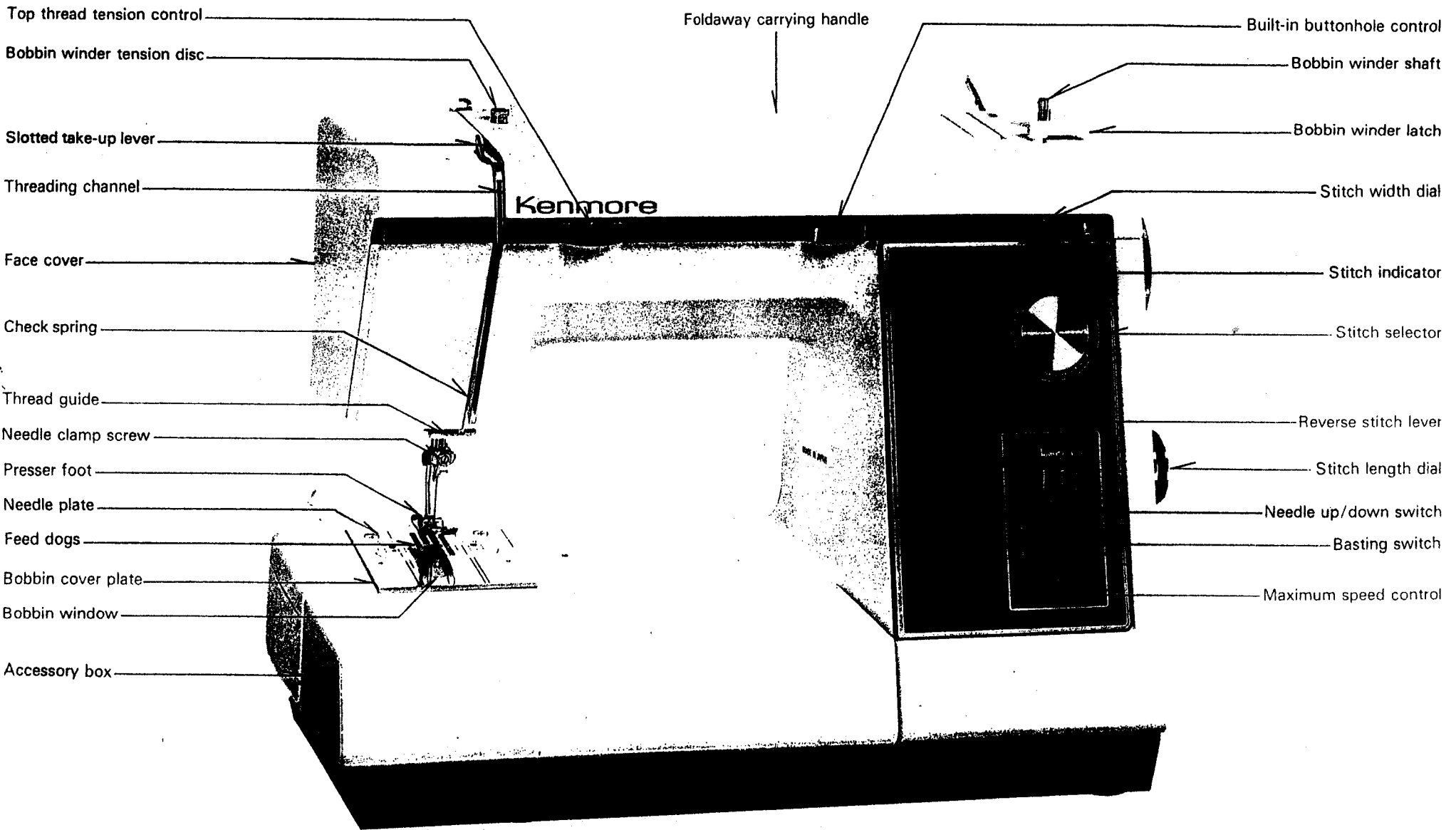

TABLE OF CONTENTS

1. KNOWING YOUR SEWING MACHINE	
Machine identification	2 - 3
Setting up your machine	4 - 5
Foot control, Light/power switch, Electronic needle control, Maximum speed control, Accessory box	
Parts list	6 - 7
Spool pins and caps	8
Converting to free-arm sewing	8
Winding the bobbin	9
Threading the bobbin case	10
Picking up bobbin thread	12
Threading top thread	11
Picking up bobbin thread	12
CONTROLS	
Thread tension control	13
Stitch selector and indicator, Stitch width control	14
Stitch length control, Reverse stitch lever, Stitch modifier ...	15
Buttonhole control, Pressure regulator	16
Seam guides, Presser foot lever	17
ACCESSORIES	
Needles, Placement of needle	18
Needle, thread and fabric chart, Presser feet	19
Even feed foot, Adjustable holder	20
Edgestitcher, Quilting guide	21
Needle plates, Feed cover plate	22
CARING FOR THE MACHINE	
Cleaning feed dogs and shuttle	23
Oiling	24 - 25
Changing light bulb	25
CHECKING PERFORMANCE PROBLEMS	26 - 27
2. STARTING TO SEW	28
Machine setting chart	29
Straight stitching	29 - 34
Fastening a seam, Turning a square corner, Removing fabric, Top-stitching, darning, Temporary sewing by machine, Zipper application-cording, Narrow hemming, Quilting	
Zigzag stitching	35 - 38
Overcasting, Satin stitching, Bar tacking, Appliqueing, Embroidery, Monogramming, Button sewing	
Mending and overcast stitching	39
Box stitch	40
Blind hemming	41 - 42
Scallop stitch	43
Stretch stitches	44 - 47
Adjusting stitch length, Adjusting stitch balance, Straight stretch stitch, Rick-rack stretch, Feather stretch, Smocking stretch, Elastic stretch, Overcast stretch, Paris point stretch	
Getting the most from fabrics that give	48 - 49
Hints on sewing different fabrics	49
Buttonhole making	50 - 58
Decorative Embroidery designs	59 - 60
WARRANTY	Inside back cover

1. KNOWING YOUR SEWING MACHINE

IDENTIFICATION CHART



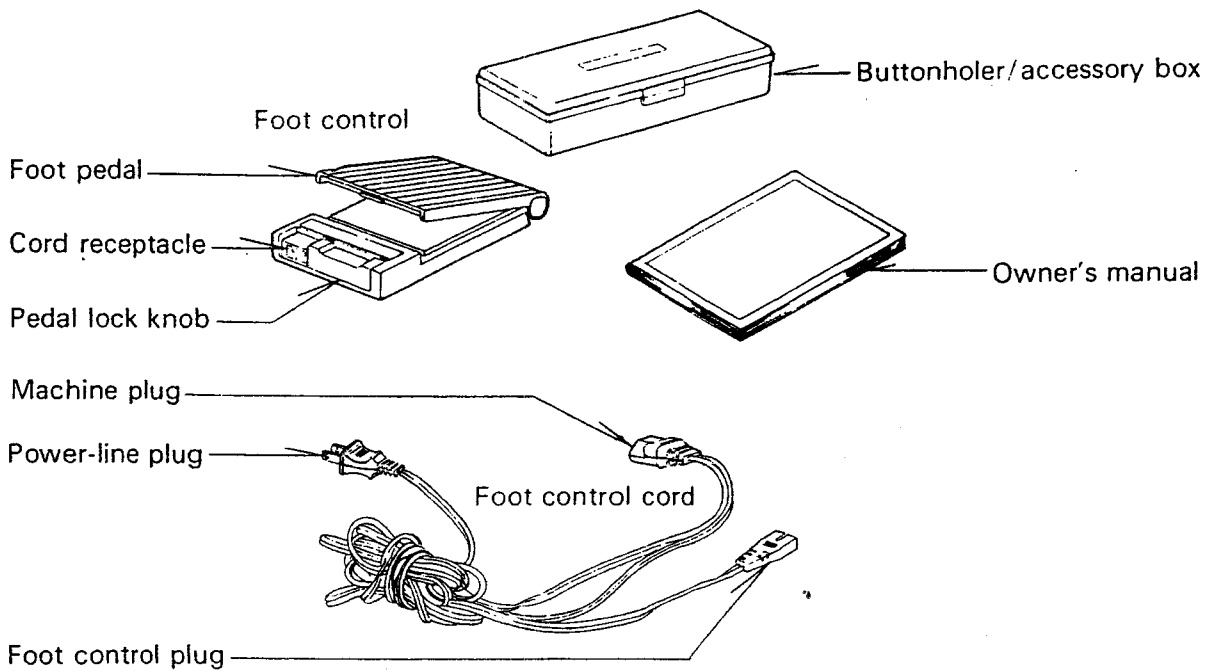
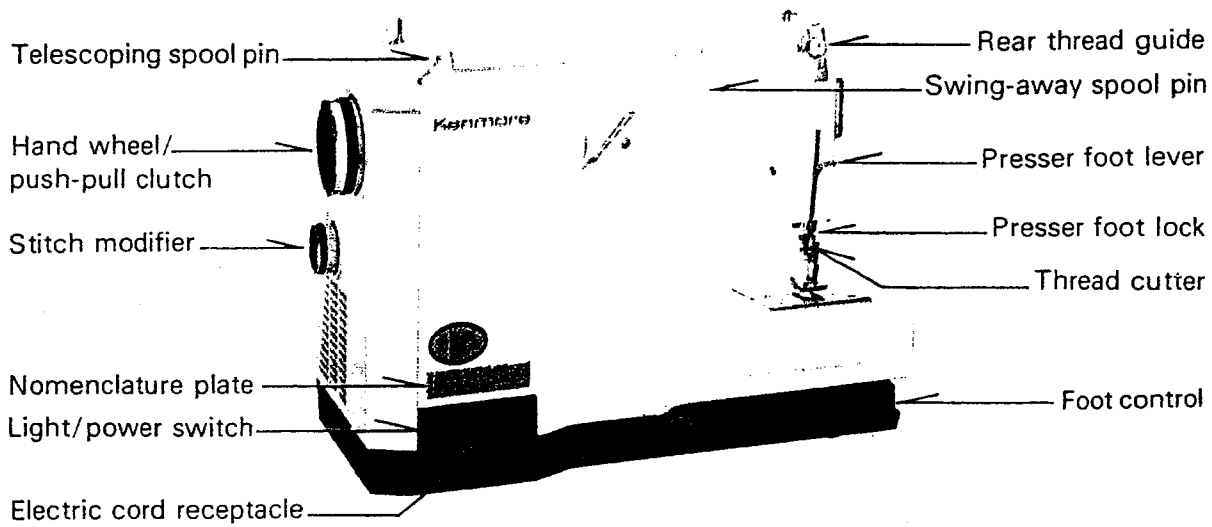

SETTING UP YOUR MACHINE

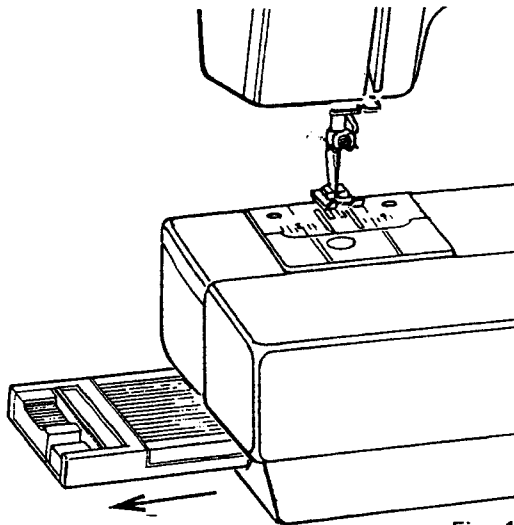

Fig. 1

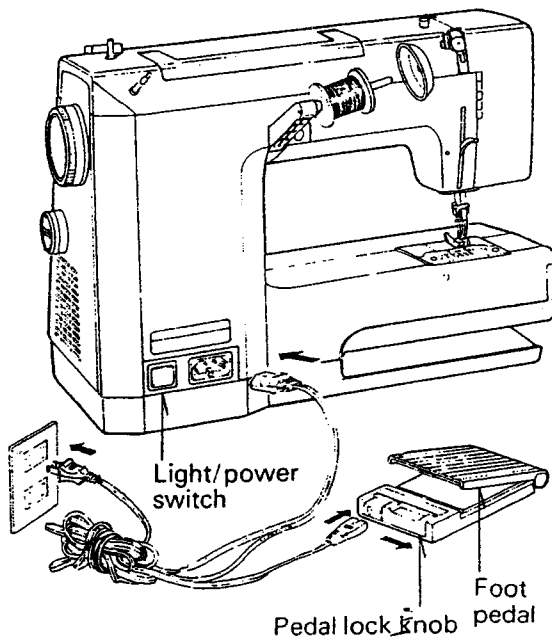

Fig. 2

1. Install your Kenmore sewing machine in a Kenmore cabinet, case or set the machine on a sturdy flat surface.
2. Your Kenmore sewing machine has been thoroughly oiled at the factory. Be sure to wipe off the needle plate area and bed plate carefully before sewing a garment. It is wise to practice on a scrap of fabric so any surplus oil is absorbed.

3. FOOT CONTROL

Your machine is supplied with an electronic foot control which enables you to sew very slowly. Even at low speed you have extra power for the needle to penetrate through several thicknesses of fabric. Faster speeds are also easily controlled.

1. Pull out the foot control from its storage position under the free arm. (Fig. 1)

2. Slide pedal lock knob to the right and the foot pedal will pop up to its operating position. Push foot control plug into the cord receptacle on the foot control. (Fig. 2)

3. Push machine plug into the cord receptacle at the rear side of the machine. Then connect power-line plug into any 110-120 volt A.C. wall outlet. (Fig. 2)

4. LIGHT/POWER SWITCH

Your machine **will not operate** unless the light/power switch is turned on. This same switch controls the machine power, sewing light and indicator lights on the stitch indicator panel and electronic needle control. If you are interrupted or stop sewing, turn off the switch.

5. ELECTRONIC NEEDLE CONTROL

Your machine is electronically controlled to stop with the needle in the up position every time you remove pressure from foot control.

NEEDLE UP/DOWN SWITCH

If you wish the machine to stop with the needle in the down position (as in turning a corner), push the left switch. A red light will appear showing you that the machine is so set. To return to the Needle Up position push the left switch again and when the light disappears, machine is again set to stop with the needle in an up position each time.

BASTING SWITCH

Tap the foot control with the right switch pushed and lighted and the machine will take one stitch only and stop with needle in the up position. This feature provides an electronically controlled basting or tacking to take the chore out of hand basting.

6. MAXIMUM SPEED CONTROL

You may want to vary the speed of the machine, sewing slowly in special tight places or if you are a new seamstress. This control can be moved to the left to slow the sewing of the machine. To increase to the maximum speed, slide the control to the right.

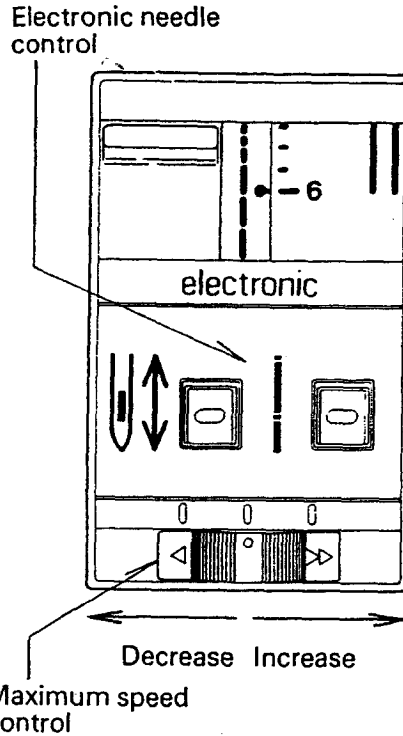

7. ACCESSORY BOX

Accessory box is opened by lifting the lid up and swinging it toward you as shown. Inside you will find many of the accessories that you use each time you sew.

The box may be fully removed from the machine to convert it for free arm stitching. See page 8.

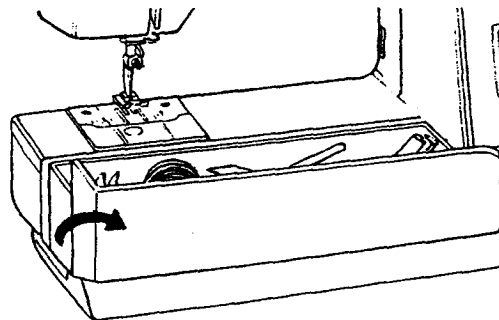

PARTS LIST (Use only genuine Kenmore replacement parts and accessories.)

All parts listed herein may be ordered from any Sears, Roebuck and Co. store or service center.

WHEN ORDERING REPAIR PARTS, ALWAYS GIVE THE FOLLOWING INFORMATION:

1. PART NUMBER
2. PART DESCRIPTION

3. MODEL NUMBER shown on the nomenclature plate. (See page 3 for location.)

4. NAME OF ITEM

If the parts you need are not stocked locally, your order will be electronically transmitted to a Sears Repair Parts Distribution Center for expedited handling.

PRESSER FEET

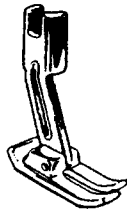

Straight Stitch
(No. 45171)

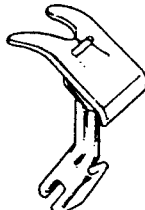

Standard Zigzag
(No. 44985)

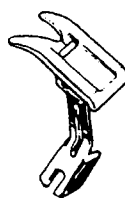

Satin Stitch
(No. 44988)

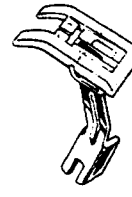

Plastic Satin
Stitch (No. 43776)

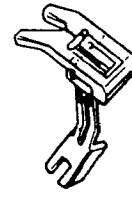

"Q FOOT"
(No. 6843)



"Q SET"
(No. 6858)

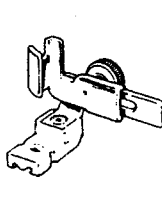

Zipper Foot
(No. 6759)

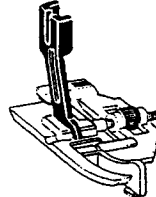

Blind Hem Foot
(No. 6886)

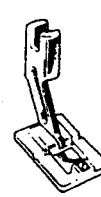

Overcasting
(No. 35094)

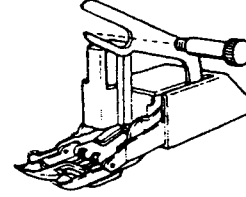

* Even Feed Foot
(No. 6888)

* Included in the buttonholer box

BUTTONHOLE ACCESSORIES

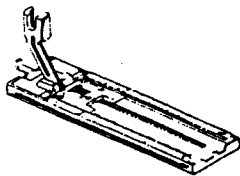

Built-in Buttonhole Guide
Foot (No. 43840)

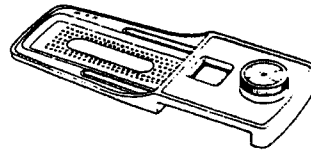

Buttonhole Guideplate
(No. 58232)

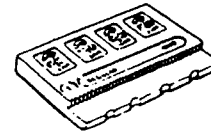

Buttonhole Templates
No. 1 Part 45195
No. 2 Part 45196
No. 3 Part 45197
No. 4 Part 45198
No. 5 Part 45199

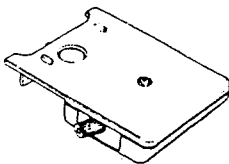

Buttonhole Cover
Plate (No. 58210)

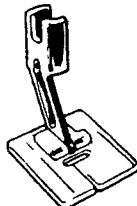

Buttonhole Foot
(No. 41040)

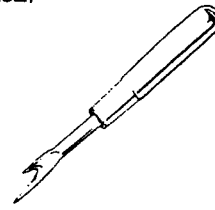

Buttonhole Opener
(No. 6830)

OTHER VITAL ITEMS



Zigzag
Needleplate
(No. 57860)



Straight Stitch
Needleplate
(No. 57861)

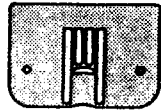

Feed Cover
Plate
(No. 43166)

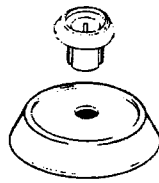

2 Spool Pin Caps
Large – No. 55503
Small – No. 53871



Nylon Disc
(No. 2273)

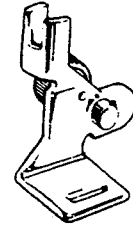

Adjustable
Holder
(No. 29308)

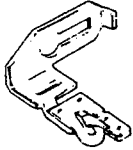

Narrow Hemmer
(No. 29396)



Edge Stitcher
(No. 29306)

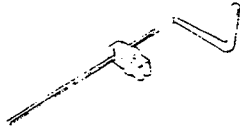

Quilting Guide
(No. 35105)



Lint Brush
(No. 35848)

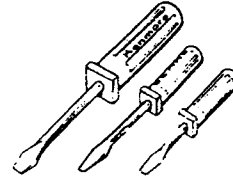

Large Screw Driver
(No. 55501)
Small Screw Driver
(No. 55500)
Magnetized
Mini Screw Driver
(No. 55499)



Bobbin Winder
Rubber Ring
(No. 1913)



Bobbin Winder
Tension Disc
(No. 39619)



Light Bulb
(No. 6797)

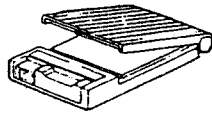

Foot Control
(No. 57544)

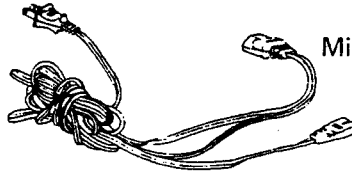

Foot Control Cord
(No. 57543)

OPTIONAL ACCESSORIES



Packet of needles
with your machine
includes a variety of sizes.
Replacement needles
come in packages
of one size only.

Needle Size	Part No.
No. 9	6550
No. 11	6551
No. 14	6552
No. 16	6553
No. 18	6554
"Q NEEDLE"	6746
Double Needle	6749

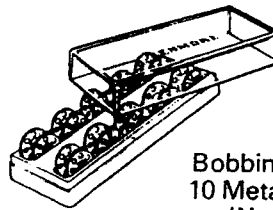

Bobbin Box with
10 Metal Bobbins
(No. 6862)
Plastic Bobbins
(No. 6868)

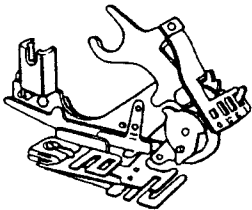

Ruffler/Pleater
(No. 6895)

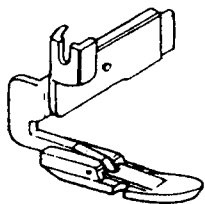

Hinged Zipper
Foot (No. 6794)

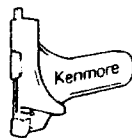

Needle Threader
(No. 43780)

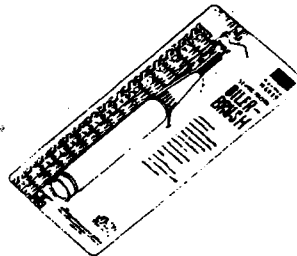

Oiler-brush Combination
(No. 6889)

SPOOL PINS AND CAPS

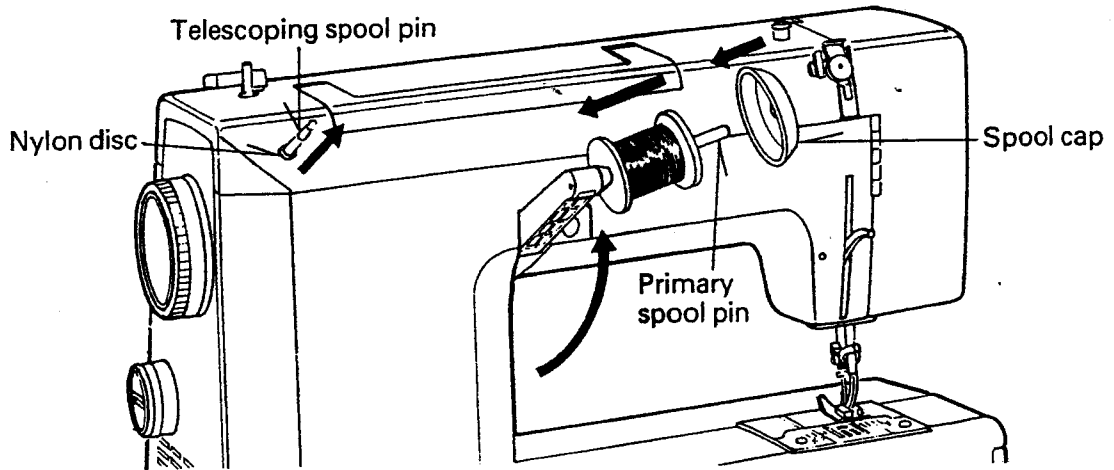

Swing the Primary Spool Pin into position at the back of the machine as shown above. Place a spool of thread on the pin and place the appropriate size spool cap over the thread.

A second telescoping spool pin is provided for bobbin winding and for a second thread when sewing with a double needle. Pull it out and place a nylon disc over it when using.

CONVERTING TO FREE-ARM SEWING

This machine can be used either as a flatbed or as a freearm model. With the accessory box in place, the machine is a flatbed model with a large working surface, which slopes gently towards you to help the smooth flow of fabric.

By removing the accessory box, the machine converts into a slim freearm model for sewing children's clothes, cuffs, trouser legs, armholes and other awkward places.

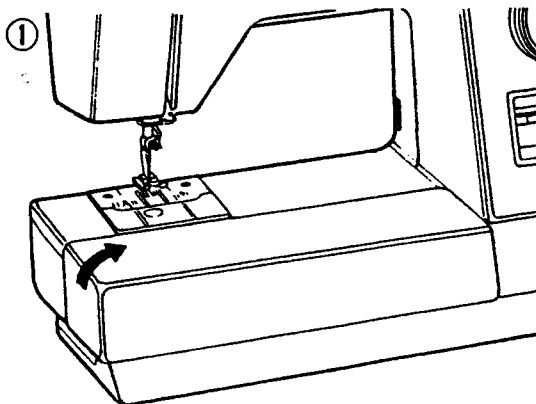

1. To remove the accessory box, take it firmly with your left hand and lift it up until it clicks. Your machine is then ready for free arm sewing.

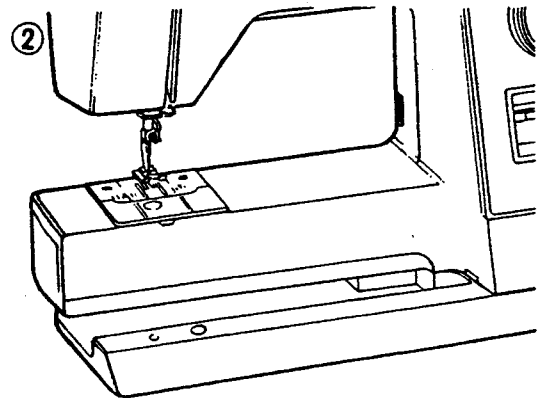

2. To replace, slide the accessory box back into place until it clicks.

WINDING THE BOBBIN

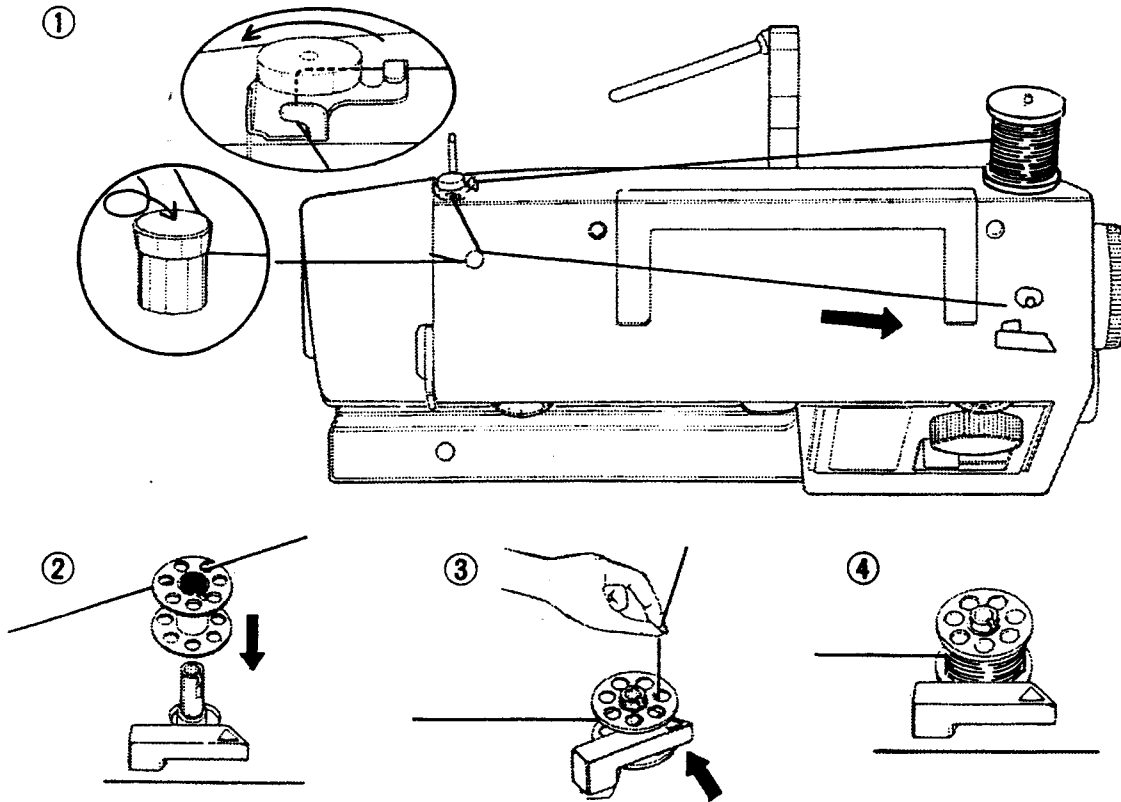

1. Place thread on Telescoping Spool Pin. Draw thread through Rear Thread Guide and Bobbin Winder Tension Disc as indicated.
2. Pull end of thread through any hole in bobbin; place bobbin on Bobbin Winder Shaft with end of thread coming from top of bobbin as shown above.
3. Push Bobbin Winder Latch against bobbin until it clicks. Then pull Hand Wheel away from machine to disengage clutch (see diagram below). Hold end of thread coming from bobbin (see above) and step on foot control. After several rotations of bobbin release thread.
4. When bobbin is full, winding stops automatically. Push in Hand Wheel. Remove bobbin from shaft and trim thread end.

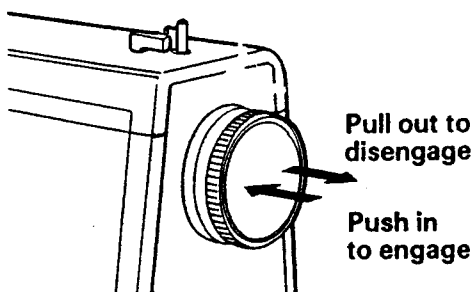

- * **Treat Hand Wheel as a "clutch"**
It controls the needle mechanism so that when pulled out (disengaged), the rest of the machine will not operate while the bobbin is being wound.

For best stitching results use clear plastic lightweight bobbins when stitching at high speed with widest and longest stitch setting.

THREADING THE BOBBIN CASE

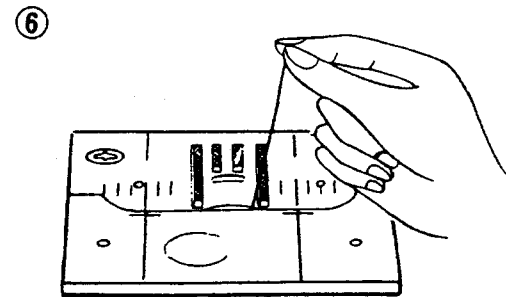
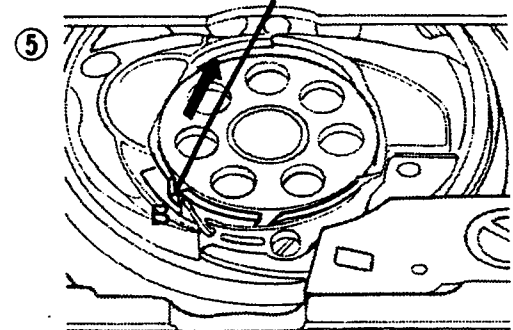
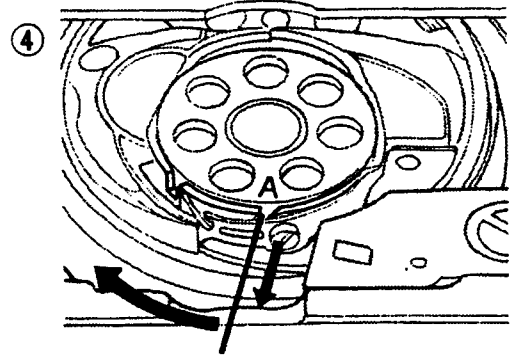
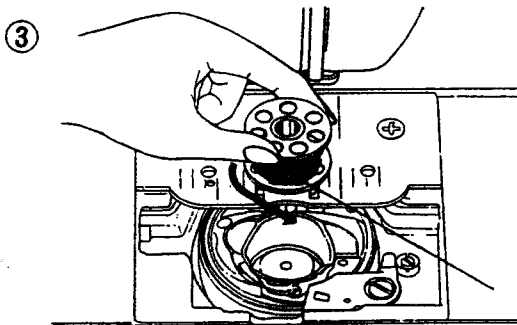
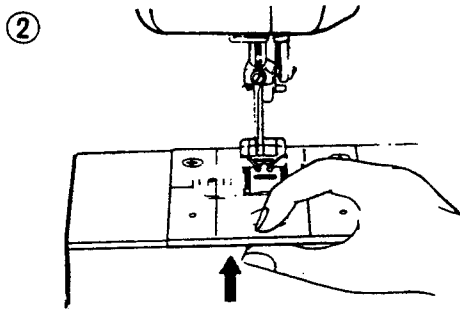
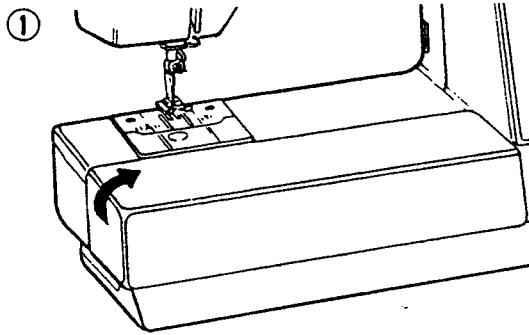

1. Remove accessory box.
2. Remove bobbin cover plate by lifting up the front.
3. Insert bobbin into bobbin case making sure bobbin rotates counter clockwise.
4. Pull thread through slot (A) and then to the left.
5. Pull thread through slot (B) and leave about 4 inches of thread.
6. Replace bobbin cover plate allowing thread to emerge through slot in needle plate.

THREADING TOP THREAD

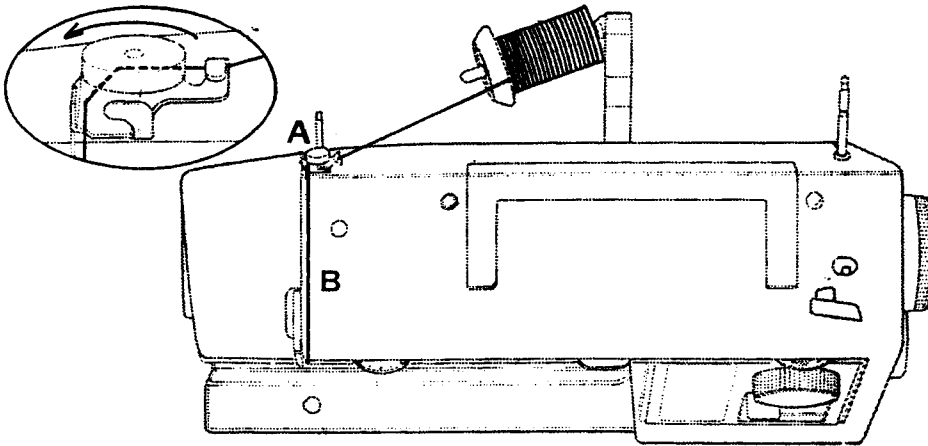

Fig. 1

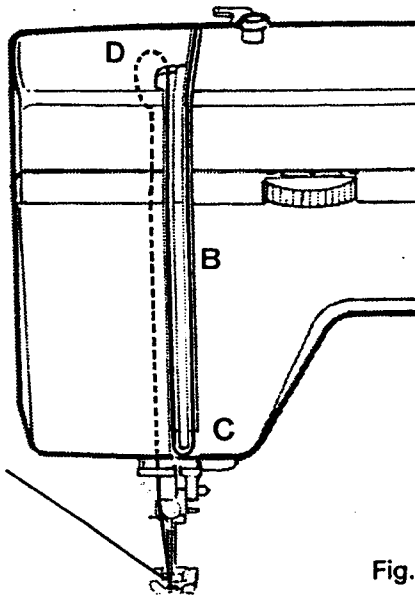

Fig. 2

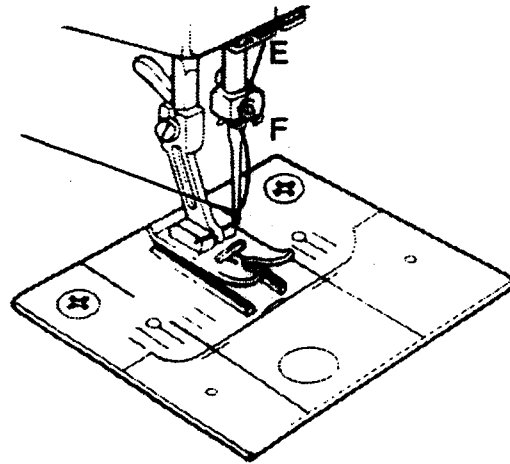

Fig. 3

1. Raise slotted take-up lever to its highest position.

Place thread spool onto spool pin. Place appropriate spool cap over the spool of thread.

Draw thread through rear thread guide (A) and into threading channel (B) toward you. (Fig. 1)

2. Draw thread down and around check spring (C) and up through slotted take-up lever (D). (Fig. 2)
3. Draw thread down into thread guides (E) and (F). Thread needle from front to back as shown in Fig. 3.

PICKING UP BOBBIN THREAD

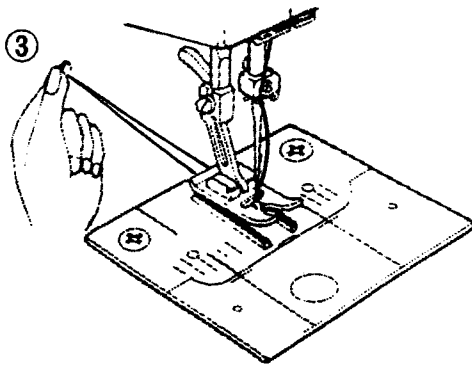
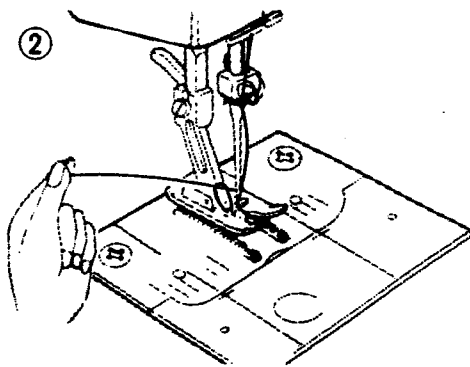
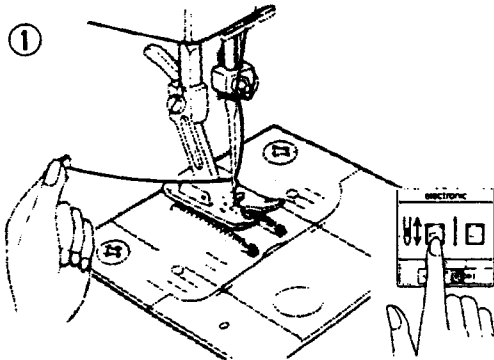

1. Raise presser foot lever.

Hold needle thread loosely in left hand and push needle up/down switch **two times** or rotate hand wheel toward you one complete turn.

2. Bring bobbin thread up by pulling upper thread.

3. Pull both threads under and to the back of the presser foot, leaving 3 to 4 inches of thread clear.

If you can not pick up bottom thread by following above steps, then check:

1. Is needle threaded ?
2. Is thread tangled around needle ?
3. Is bobbin case threaded correctly with thread going through slots A and B as shown on page 10, Fig. 4 and 5 ?
4. Is there 4 inches of thread coming from bobbin case and through slot of needle plate as shown on page 10, Fig. 6 ?
5. Is thread from bobbin case tangled ?

CONTROLS

THREAD TENSION CONTROL

STRAIGHT STITCHING

The good looking appearance of your straight stitching is, mainly determined by the balanced tension of the top thread and bobbin thread. The tension is well balanced when the two threads lock in the middle of the layers of fabric when straight stitching.

You can achieve balanced tension by regulating the Top Thread Tension Control. If the upper thread appears to be too **tight**, dial left (lower numbers) to **decrease** tension. If the upper thread is too **loose**, dial right (higher numbers) to **increase** tension.

For most fabrics the tension control should be set in the white zone between 3 and 5.

ZIGZAG STITCHING

Always practice stitching on two layers of the fabric you will be using.

Make sure that you are using the right size and type of needle for the fabric. See chart page 19.

Choose a thread of good quality and type for your fabric. See chart page 19.

Remember — the wider the zigzag setting, the more chance for puckering. Reduce the top tension, if puckering occurs.

The **top** thread will be visible on the bottom to varying degrees depending on the thread, fabric, type of stitch being used and speed of sewing.

The **bobbin** thread should never be visible on the top of the fabric.

BOBBIN TENSION

The bobbin tension has been correctly set at the factory, so you do not need to adjust it.

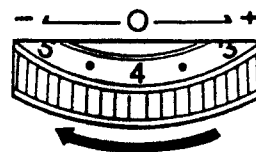

Decrease tension

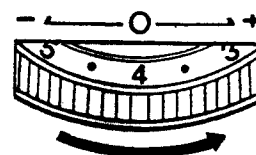

Increase tension

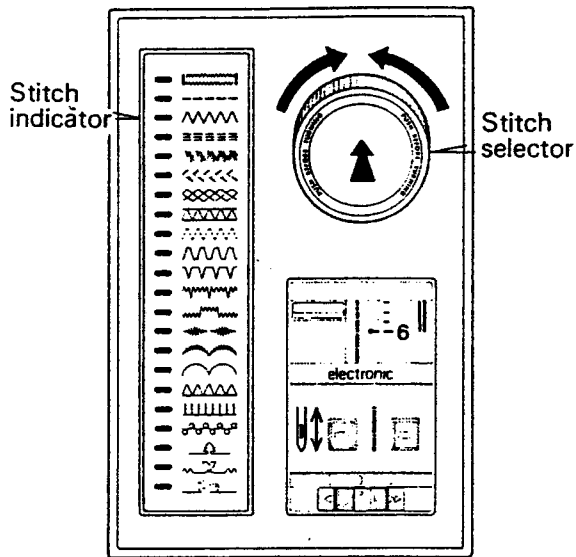

STITCH SELECTOR AND INDICATOR

1. To select a stitch, be sure needle is out of fabric at its highest position. Push the stitch selector in and out to release the mechanism.
2. Then turn the selector to left or right until the required stitch is indicated by the red light on the indicator panel.

STITCH WIDTH CONTROL

The width of all the stitches produced on this machine, with the obvious exception of straight stitch, can be made narrower or wider by adjusting the stitch width control.

To decrease or increase the width of a stitch, turn the stitch width control dial from 0 - 4. The higher the number the wider the stitch.

Recommended setting ranges are indicated and color-coded with patterns on the stitch indicator panel.

When sewing with a double needle, do not use a setting above 2, as indicated on the dial.

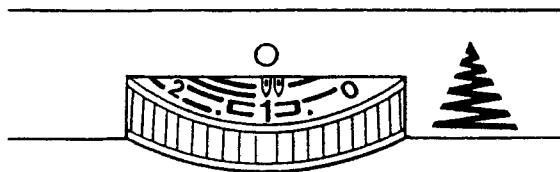

STITCH LENGTH CONTROL

The stitch length control regulates the length of the stitch you select. **THE HIGHER THE NUMBER-THE SHORTER THE STITCH.** Turn only the **outer rim** of this control to set the stitch length.

The number on stitch length control indicates the approximate number of stitches per inch. The stitch setting you use will be determined by the thickness of the fabric you are sewing.

A longer stitch setting should be used for thicker fabric or more layers of fabric. The middle range of the control is the 12 stitch per inch range which is the most commonly used.

Recommended stitch length settings are indicated in three colors. The colors are color-coded with the stitches on the indicator panel.

The red marking **—** between 0 and 1 is the setting used for the shortest stitches such as in satin stitching.

REVERSE STITCH LEVER

It is best to begin and end seams with a few stitches taken in reverse. This is called **back tacking**. Back tacking fastens the ends of the seams firmly and prevents raveling.

When reverse stitching is needed, push down the lever and hold there during sewing. The fabric will immediately start feeding backwards and seam will be fastened.

STITCH MODIFIER

When using stretch stitches and making buttonholes, you may need to make use of the stitch modifier. This regulates the movement of the fabric backwards and forwards to produce perfect stitches on fine or thick fabrics.

The stitch modifier should be in neutral notched position for most materials.

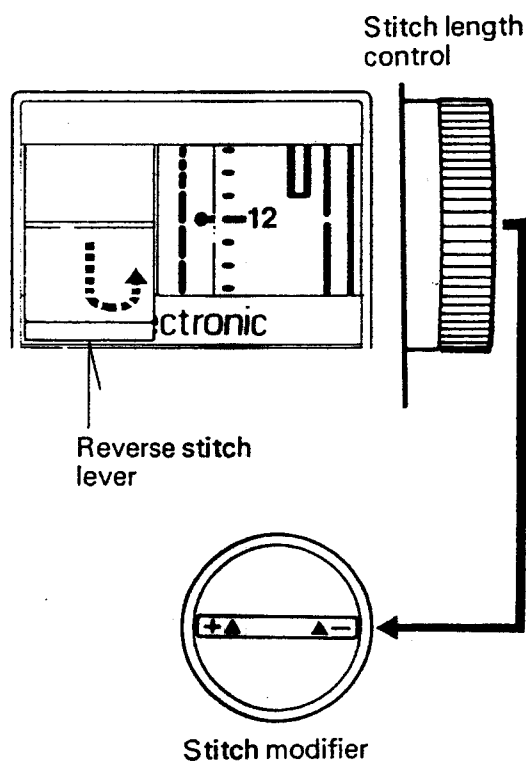

BUTTONHOLE CONTROL

This control is used in making bar tacked buttonholes with two control settings. Detailed instructions are given on page 51.

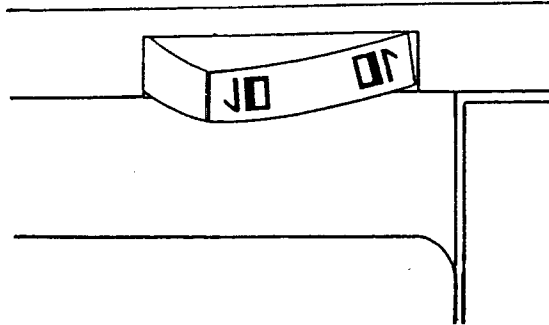

PRESSURE REGULATOR

Presser foot pressure is vital for straight seams, uniform stitch length, even handling of both layers of fabric. To adjust pressure; use Pressure Regulator which is situated inside the face cover. Then to **increase** pressure, turn the dial clockwise (or vice versa). Just remember... for **lightweight** fabric, more pressure; for heavy fabric, less pressure.

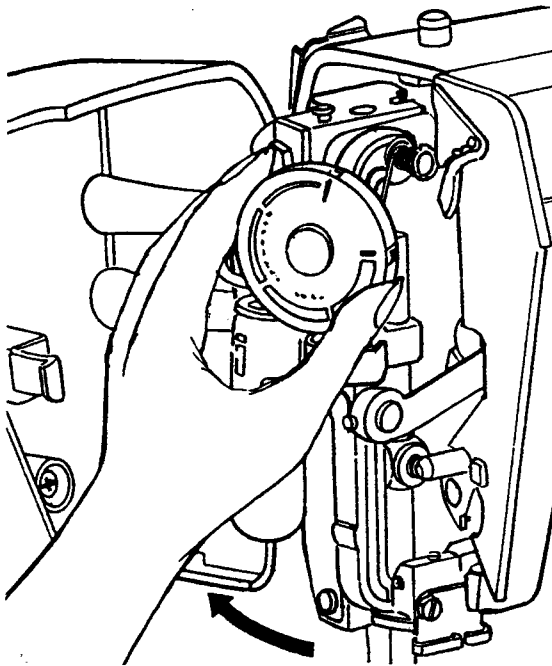

SEAM GUIDES

Seam guides are printed on needle plate, at both sides of needle, to help you line up the fabric and keep it straight. The standard seam width is $5/8$ ". So these lines are emphasized, easy to follow.

Also the cross lines are "cornering guides" to help when turning a square corner $5/8$ " from the fabric edge. (For details on cornering, see page 30.)

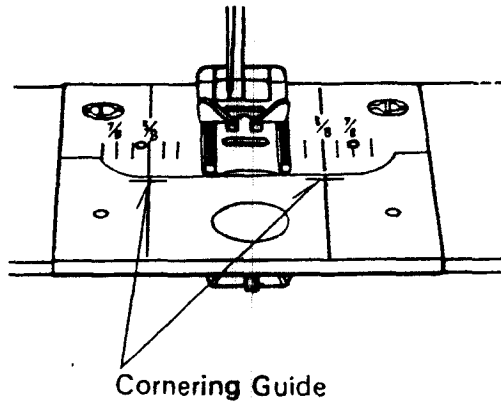

PRESSER FOOT LEVER

Presser foot lever has a two position lift. In order to place heavy fabric under the presser foot or to change the presser foot raise the presser foot lever to its maximum upward position as shown.

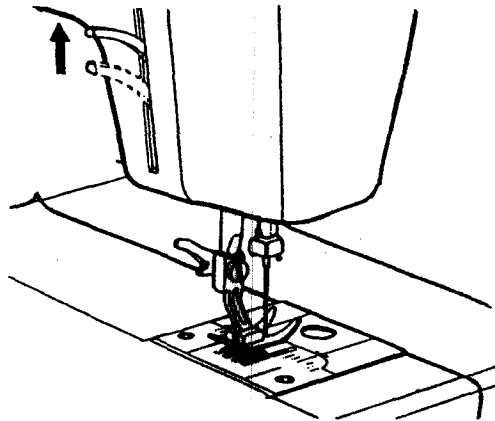

ACCESSORIES

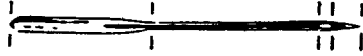

NEEDLES

Use KENMORE needles. The size of the needle should conform with the size of the thread and both should be suitable to the fabric. Kenmore needles are color-coded by size for your convenience (See chart on next page).

Never use a bent needle or one with a dull point.

The exact length of your needle is shown at left. Be sure you never use one in your machine that is not this exact length.

You will find among your accessories a "Q NEEDLE"™ with blue shank. This special needle is to be used when sewing knits and certain difficult synthetic fabrics. If you experience **skipped stitches** in any of your sewing, use "Q NEEDLE"™ and "Q FOOT"™.

PLACEMENT OF NEEDLE

Raise needle bar to its highest position by turning the hand wheel toward you. Loosen the needle clamp screw. Holding the needle with the flat side away from you, slip the needle into the needle bar. When it is in as far as it will go, tighten the needle clamp screw with small screwdriver provided in the accessory box.

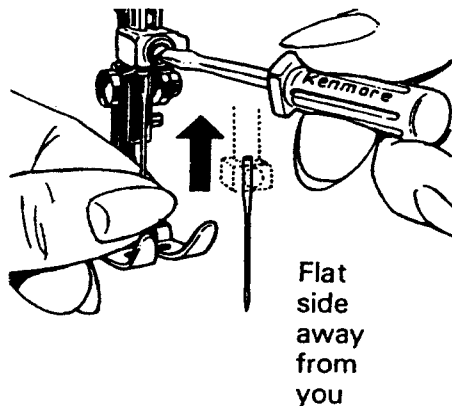

NEEDLE, THREAD AND FABRIC CHART

FABRIC	NEEDLE SIZE AND COLOR	THREAD SIZE	RECOMMENDED STITCH LENGTH SETTING
LIGHTWEIGHT: Batiste, Dimity, Chiffon, Silks, Synthetic Jerseys, Fine Lace, Organza, Crepe, Taffeta, Voile, Organdy	9-BROWN or 11-ORANGE	Polyester Core/ Cotton Wrap Fine Mercerized Cotton Silk A	12 stitches per inch
MEDIUMWEIGHT: Cotton, Cotton Blends, Percale, Gingham, Shantung, Pique, Seersucker, Satin, Knits, Vinyl, Suitings, Linen, Wool Crepe, Leather	14-RED	Polyester Core/ Cotton Wrap 50 Mercerized Cotton Silk A	10 to 12 stitches per inch
MEDIUM HEAVYWEIGHT: Corduroy, Denim, Wool, Sailcloth, Wool Flannel, Gabardine, Velvets, Leather	14-RED or 16-PURPLE	Polyester Core/ Cotton Wrap 50 Mercerized Cotton Mercerized Heavy-Duty Silk A	8 to 10 stitches per inch
HEAVYWEIGHT: Coatings, Upholstery, Cotton Duck, Heavy Twills, Canvas	18-GREEN	Polyester Core/ Cotton Wrap Heavy-Duty Mercerized Cotton Polyester Synthetic Silk A	8 stitches per inch
Decorative top-stitching on all types of fabric	16-PURPLE 18-GREEN or Q-BLUE	Buttonhole Twist	6 stitches per inch
Synthetic Knits and Stretch: Polyester Double Knits, Nylon Tricot, Jersey, Stretch Terry, Spandex, Cire Tricot	Q-BLUE with "Q FOOT"	Polyester Core/ Cotton Wrap 50 Mercerized Cotton	10 for Regular or 6 for Stretch Stitches

PRESSER FEET

To change presser feet, simply drop Presser Foot Lock and slip foot away from the Presser Bar. Raise Presser Foot Lever beyond the normal up position and place new foot on presser bar. To lock foot securely, raise presser foot lock as high as possible.

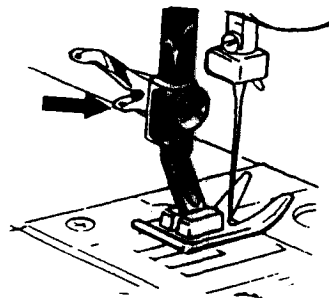

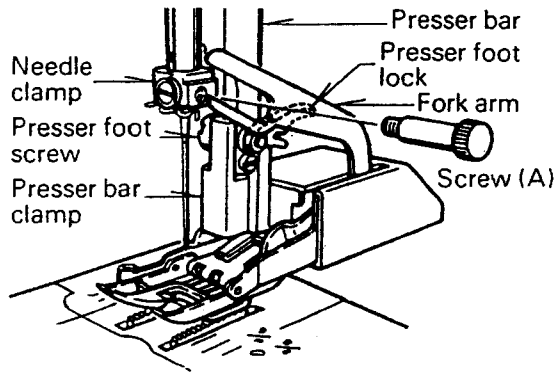

Fig. 1

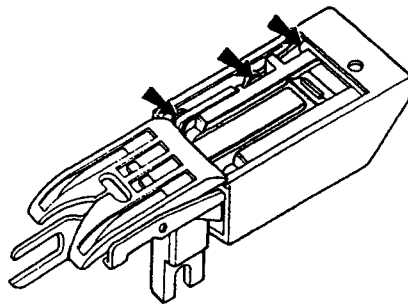
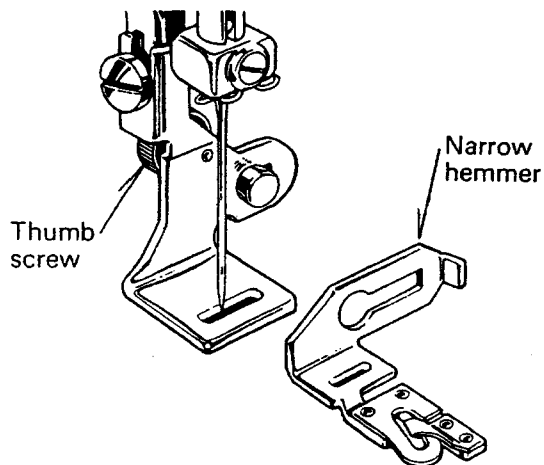

Fig. 2



EVEN FEED FOOT

The even feed foot moves top and bottom material together evenly and enables you to sew hard-to-sew fabrics without slipping and with perfect matching. Use it for sewing leather, ultra suede™, shiny fabrics (vinyls, patents and satins), bonded fabrics, pile fabrics and matching stripes, plaids and patterns. It is not recommended for use when stretch stitching.

To attach the even feed foot;

1. Raise needle to its highest position.
2. Raise presser bar to its highest position and guide the even feed foot into position from rear of machine.
3. Attach presser bar clamp to presser bar and lift presser foot lock as high as it will go to hold the foot securely.
4. Attach screw (A) provided with the foot to needle clamp through fork arm and tighten it.

Note: Attach the foot in exact order of steps as written.

IMPORTANT:

To prevent friction and wear, put a drop of oil at each point indicated by arrows in Fig. 2 and set pressure regulator at 2 or 3 before using this foot.

Oil after 4 or 5 times usage. Be sure to remove excess oil by wiping foot thoroughly and sewing on a scrap of fabric.

ADJUSTABLE HOLDER

Replace the regular presser foot with the adjustable holder when using narrow hemmer and edge stitcher attachment.

Loosen thumb screw and press it forward. Insert the opposite end into the large hole of the attachment. Slide the attachment to the left as far as possible. Adjust as necessary to the correct position for stitching. Tighten the thumb screw securely.

EDGESTITCHER

This one attachment helps you join fabric edges ...insert lace ...do seam piping ...simplifies blind hemming as well as "French" seams. Slots numbered 1 to 5 serve as sewing guides:

Slot 1 will guide fabric to be joined to lace. All you have to do is place the lace in slot 2.

Slot 4 will guide piping being joined to fabric edges. Place the fabric in slots 2 or 3.

Slot 5 may be used as a guide when sewing French seams which are stitched twice, once on **right** side and once on **other** side. This is the classic seam for sheers.

Use slots **1 and 3** to guide fabric with ease during blind hemming.

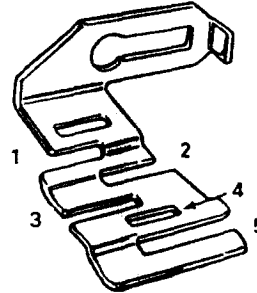

QUILTING GUIDE

This attachment comes in handy whenever you want several rows of stitches an equal distance apart — for garment trim as well as quilts. It consists of a curved prong attached to a long bar on a holder. The prong is shifted back and forth on the holder to establish the distance between rows of stitches.

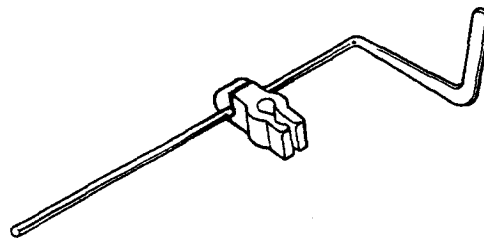

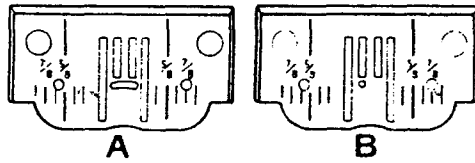

Fig. 1

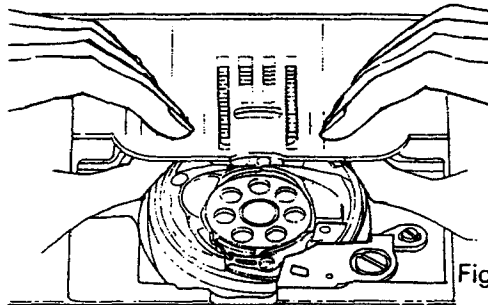
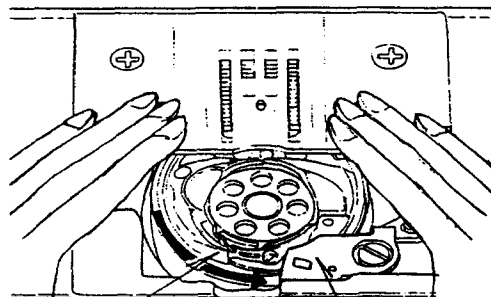
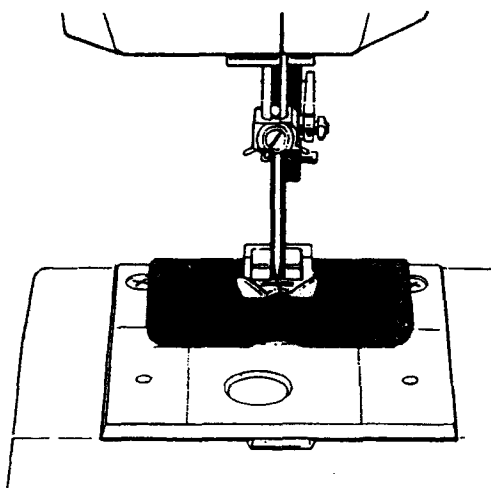

Fig. 2



Bobbin case Bobbin case stopper Fig. 3



NEEDLE PLATES

You are provided with two needle plates:

- A. Needle plate with wide oval hole for all zigzag stitching.
- B. Needle plate with round hole for regular straight stitching and straight stretch sewing.

CHANGING NEEDLE PLATE

1. Raise needle to its highest position and raise presser foot.
2. Remove accessory box and bobbin cover plate.
3. Remove needle plate by placing thumb under edge of plate and lifting up and out. (See Fig. 2)
4. Place other needle plate making sure bobbin case is in proper position as shown in Fig. 3 by turning it counter-clockwise until it hits bobbin case stopper. Push down the needle plate with both hands to lock.
5. Replace bobbin cover plate.

IMPORTANT:

Don't turn hand wheel while needle plate is removed, or needle may hit bobbin case and cause needle damage.

Don't touch screws on the bobbin case stopper.

FEED COVER PLATE

There are a few times when you want to control the feeding of the fabric yourself. Raise needle to its highest position and raise presser foot. Place feed cover plate over needle plate aligning two pins of feed cover plate with holes of needle plate. You may then determine the movement of the fabric yourself.

CARING FOR THE MACHINE

CLEANING THE FEED DOGS WITH A BRUSH

To insure the best possible operation of your machine, it is necessary to keep the essential parts clean at all times.

Remove bobbin cover plate and needle plate. Using a small brush, remove the lint that accumulates in and around the feed dogs and shuttle area.

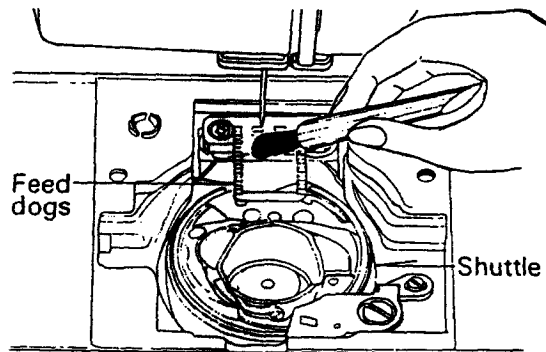

CLEANING AND OILING SHUTTLE AREA

On rare occasions, you may want to clean the shuttle area. Just follow these simple steps.

1. Remove bobbin case by lifting it out from left side.
2. Clean the shuttle with small brush and put a drop of oil to the points indicated by arrows. Don't over-oil. (Reminder: don't use household oil...use sewing machine oil.)

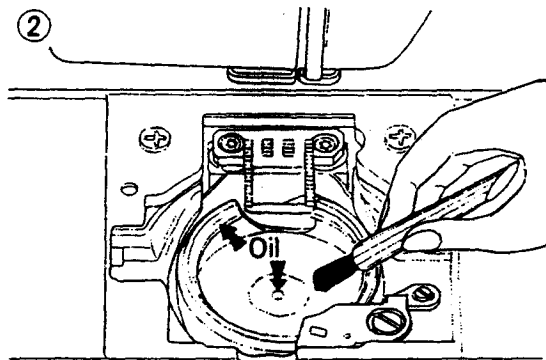
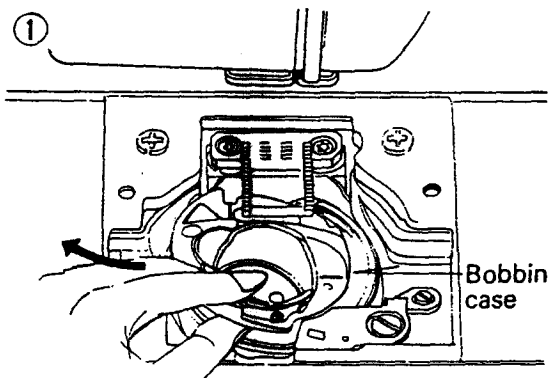

REPLACING BOBBIN CASE

1. Insert bobbin case into shuttle from left side and turn it counter-clockwise until it hits bobbin case stopper.
2. Replace needle plate in position.

NOTE: Don't touch screws on the bobbin case stopper.

Oil and lint brush No. 6889 is available at most Sears retail stores and catalog.

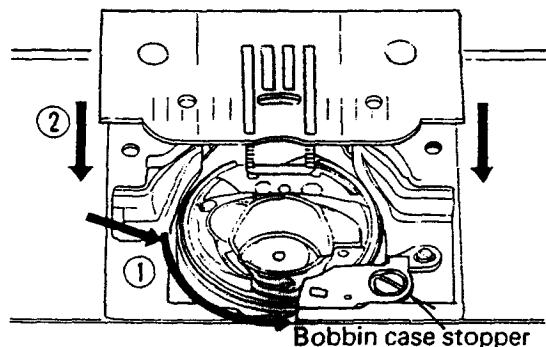

OILING UNDER TOP COVER PLATE

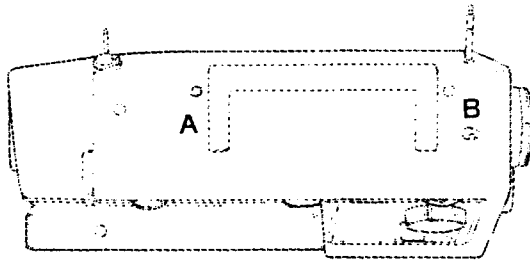

Remove top cover plate by loosening two top screws (A and B) as shown at left. Then place one or two drops of Kenmore sewing machine oil at each point.

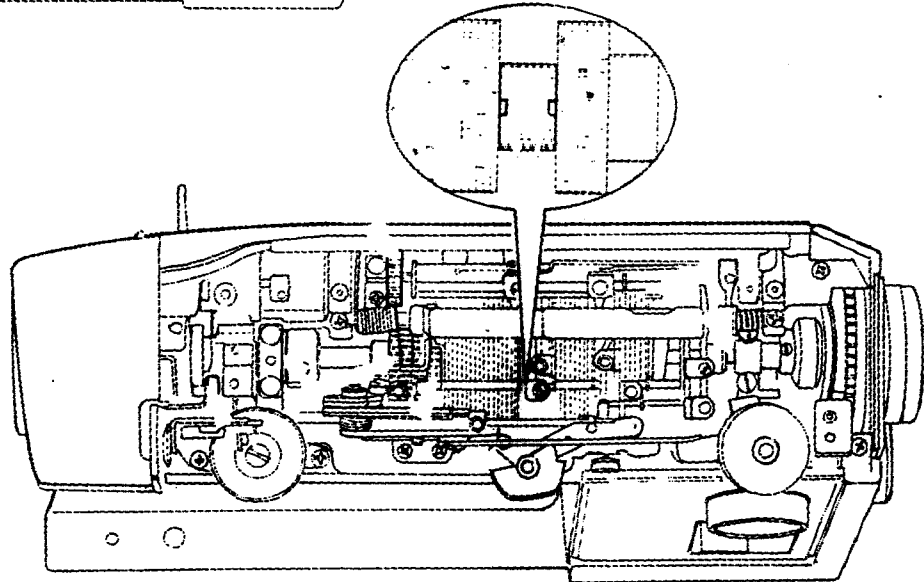

OILING UNDERSIDE

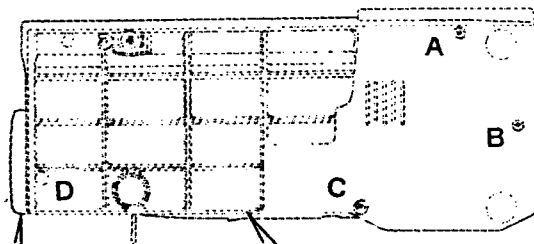

Free-arm cover

Bottom cover

Tilt back machine and remove bottom and free-arm covers by loosening four screws (A, B, C and D).

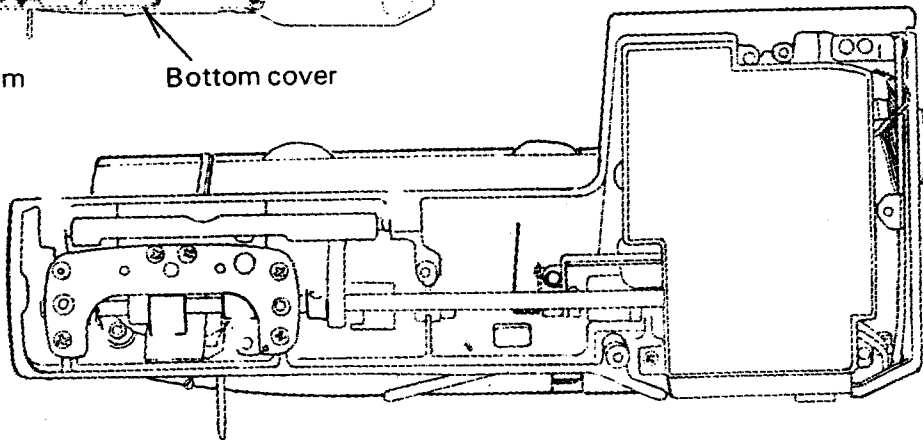

OILING IN FACE COVER PLATE

Swing face cover plate open and oil points indicated by arrows in illustration.

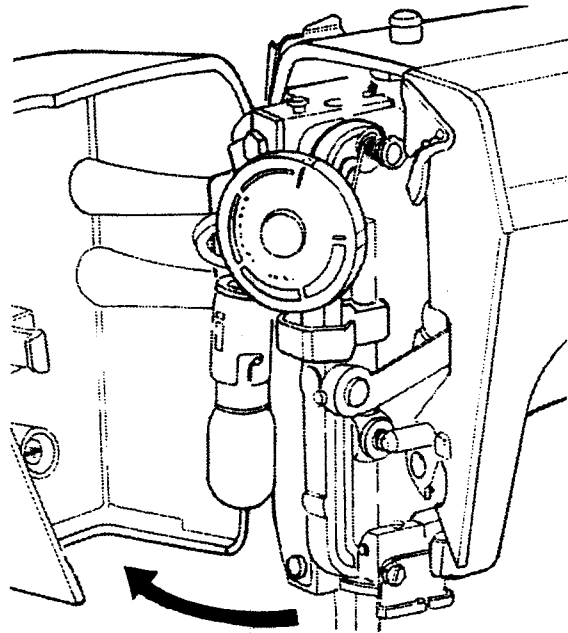

OILING IN END COVER PLATE

A drop of oil should be placed through the hole indicated in the end cover plate.

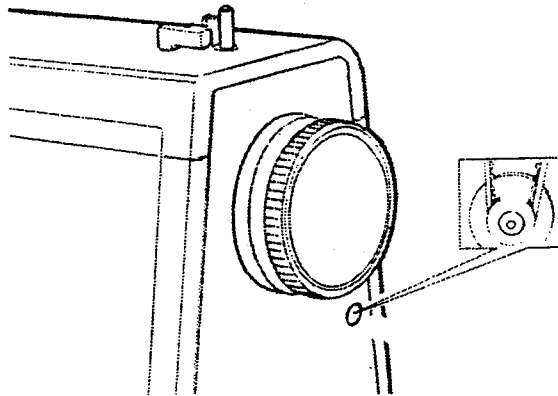

CHANGING LIGHT BULB

The sewing light is located inside the face cover plate as shown. To replace the bulb, push switch to off, unplug machine and swing the face cover plate open. Push up on the bulb slightly and turn bulb to the left. Withdraw bulb from socket. Push in new bulb and turn to the right.

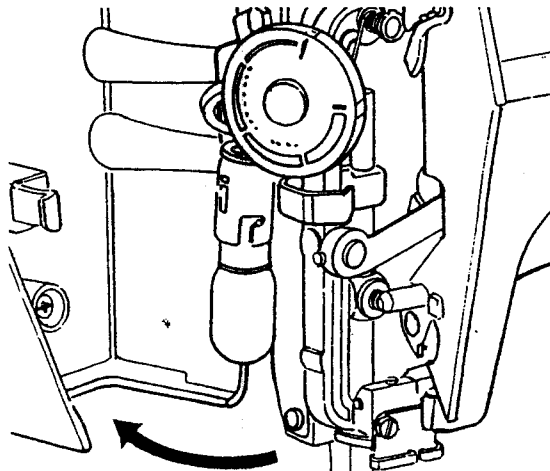

CHECKING

SUSPECTED PROBLEM	PROBABLE CAUSE
IRREGULAR STITCHES	<p>Incorrect size needle. Improper threading. Loose upper thread tension. Pulling fabric. Light pressure on presser foot. Loose presser foot. Unevenly wound bobbin. Nicks or burrs at needleplate opening.</p>
BREAKING NEEDLE	<p>Pulling fabric. Incorrect size needle. Incorrect setting of needle. Loose presser foot.</p>
BUNCHING OF THREAD	<p>Upper and lower threads not drawn back under presser foot before starting seam.</p>
PUCKERING	<p>Incorrect thread tension(s). Light pressure on presser foot. Using two different sizes or kinds of thread. Bent or blunt needle. Loose presser foot. Fabric too sheer or too soft.</p>
SKIPPING STITCHES	<p>Incorrect size needle. Certain knits and synthetics. Bent or blunt needle. Incorrect setting of needle. Tight upper thread tension. Light pressure on presser foot.</p>
BREAKING UPPER THREAD	<p>Starting to stitch too fast. Improper threading. Tight upper thread tension. Incorrect size needle. Sharp eye in needle. Nicks or burrs at needleplate opening.</p>
BREAKING BOBBIN THREAD	<p>Improper bobbin case threading. Lint in bobbin case or shuttle.</p>
FABRIC NOT MOVING	<p>Feed cover plate attached. Light pressure on presser foot. Thread knotted under fabric.</p>
MACHINE JAMMING, KNOCKING NOISE	<p>Thread caught in shuttle. Damaged needle. Bent needle plate.</p>
MACHINE DOES NOT SEW	<p>Hand wheel not returned to stitching position. Power cord not connected. Power/light switch off.</p>

POSSIBLY EASY CORRECTION

Choose correct size needle for thread and fabric.
Rethread machine; check tension spring threading.
Tighten upper thread tension.
Do not pull fabric; guide it gently.
Increase pressure on presser foot.
Reset presser foot.
Rewind bobbin.
Replace needleplate, or polish off burrs completely.

Do not pull fabric; guide it gently.
Choose correct size needle for thread and fabric.
Reset needle.
Reset presser foot.

When starting a seam be sure to draw both threads under and back of presser foot about 4" and hold until a few stitches are formed.

Reset thread tension(s).
Increase pressure on presser foot.
Upper thread and bobbin thread should be same size and kind.
Insert new needle.
Reset presser foot.
Use underlay of tissue paper.

Choose correct size needle for thread and fabric.
Use "Q NEEDLE"™ and "Q FOOT"™.
Insert new needle.
Reset needle.
Loosen upper thread tension.
Increase pressure on presser foot.

Start to stitch at a medium speed.
Rethread machine.
Loosen upper thread tension.
Choose correct size needle for thread and fabric.
Insert new needle.
Replace needleplate, or polish off burrs completely.

Check bobbin case threading.
Clean bobbin case and shuttle.

Remove feed cover plate.
Increase pressure on presser foot.
Place both threads back under presser foot before beginning to stitch.

Disassemble and clean shuttle.
Replace needle.
Replace needle plate.

Push in clutch.
Check plug.
Push to on position.

2. STARTING TO SEW

Now that you are familiar with the controls on your machine and with the accessories provided for the machine, you are ready to start to sew with your sewing machine. Below are some good habits to follow each time you sit down to sew:

1. Check the needle-it should be straight, properly set and sharp on the point. It should be the correct size for the fabric and thread being used. Do not be afraid to change your needle frequently. Many of the new fabrics made of synthetic blends tend to dull the needles more easily than fabrics made of natural fibers.
2. Before placing the material on the machine, see that the ends of the threads have been drawn about 3 - 4 inches to the rear of the machine. Hold on to threads during the sewing of the first 3 or 4 stitches of the seam.
3. Test the machine stitch on a scrap of fabric you plan to use. The fabric should be double thickness. Adjust the machine for the length of stitch and tension suitable to your fabric.
4. Fabric should be placed under the presser foot with the bulk of the material to the left of the needle and the right edge of the material placed on the 5/8" seam marking on the needle plate when making a simple seam.
5. Run the machine at a slow even speed. The more pressure you put on the foot control, the faster the machine will sew.
6. Fasten each seam by back tacking at the beginning and end of the seam.
7. Always finish sewing each seam with the needle at its highest point.
8. Guide the fabric gently with your hand in front of the needle. Never pull or hold the fabric in such a way that the normal feeding is altered.
9. When turning the hand wheel manually, always turn it toward you.

MACHINE SETTING CHART



Buttonhole control

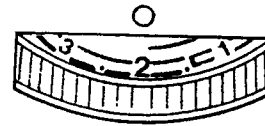
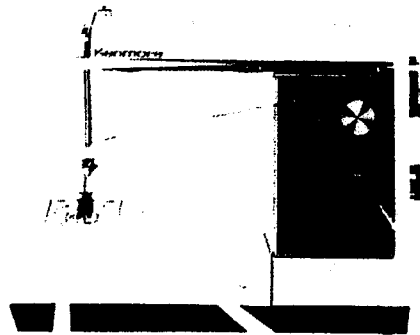

Stitch width dial

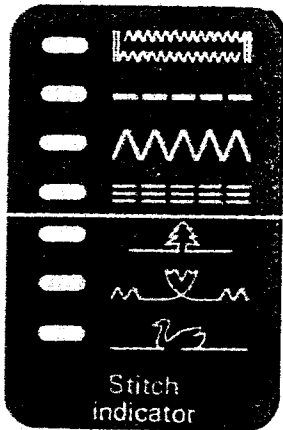

Stitch indicator

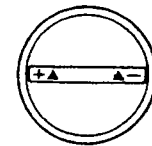

Stitch modifier

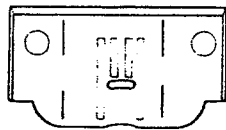

Needle plate

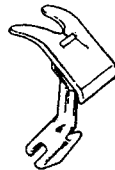

Presser foot

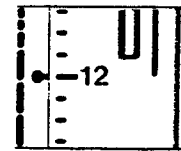

Stitch length dial

Machine settings are graphically shown in this section for your quick reference. Simply

following illustrated charts, select and sew a variety of stitches shown below...

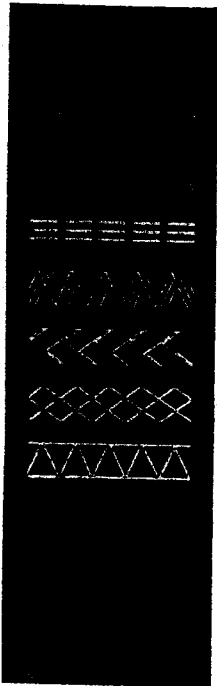

- Buttonhole
- Straight stitch
- Zigzag
- Straight stretch
- Rick-rack stretch
- Feather stretch
- Smocking stretch
- Elastic stretch
- Mending
- Box
- Blind

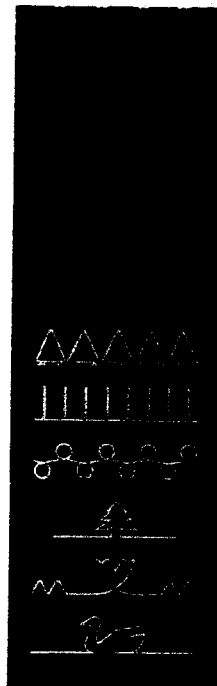

- Elastic blind stitch
- Domino
- Diamond
- Crescent
- Scallop
- Overcast stretch
- Paris point stretch
- Arabesque
- Tree
- Tulip
- Swan

STRAIGHT STITCHING

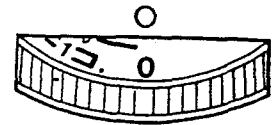
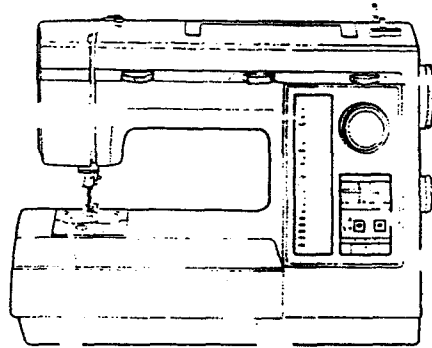
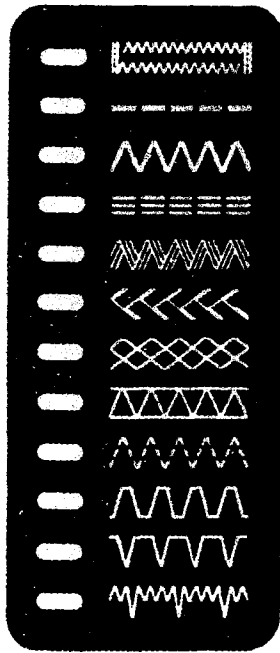

Not necessary to adjust

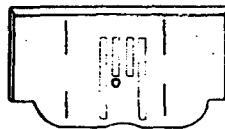
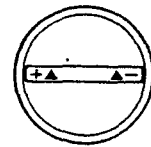

*Straight stitch needle plate



*Straight foot

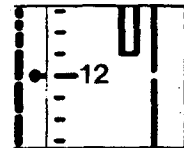

Any setting but "0"

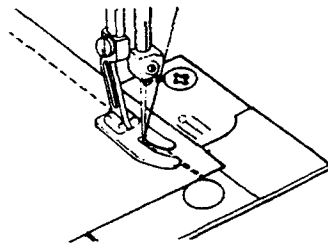

*You may use zigzag, straight stitch foot or Q foot, but for best control of fabric, best looking straight stitches and best feeding of fabric use Straight Stitch Foot and Needle Plate.

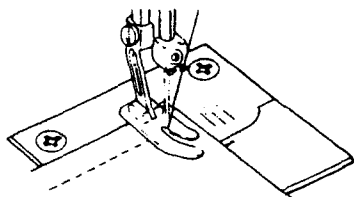
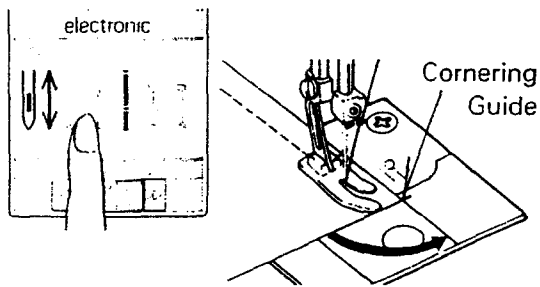

FASTENING A SEAM

Be sure both threads are drawn back under the presser foot. Lower needle into fabric about 1/2 inch from beginning of seam. Depress the reverse stitch lever and stitch in reverse until needle reaches beginning of seam. Release control and complete seam. When you reach the end, depress the reverse stitch lever and sew back (backtack) over 1/2 inch of completed seam.

TURNING A SQUARE CORNER

1. To turn a square corner 5/8" from the fabric edge, stop stitching when reaching the **cornering guide** and push **needle up/down** switch to lower the needle into the fabric.
- *2. Raise the presser foot and turn fabric. New stitching line will align with 5/8" seam guide on side of needle plate. Lower the presser foot and begin stitching in new direction.

REMOVING FABRIC

First turn the handwheel toward you until the needle is at its highest position, then raise the presser foot, draw materials to the rear and cut off excess thread with the thread cutter located on the presser bar as shown.

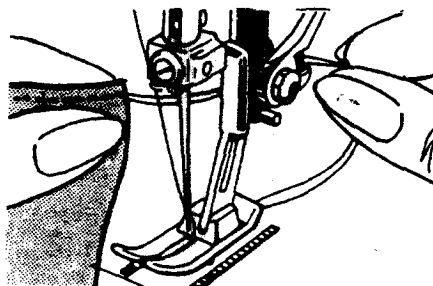

TOP-STITCHING

This is a seam you may want to show off! It's on the front side of the garment, possibly at the top of a "kick pleat" or on a lapel, both functional and decorative. Usually, it's a simple, forward stitch — with an extra-long stitch length, or with special thread, matching or contrasting.

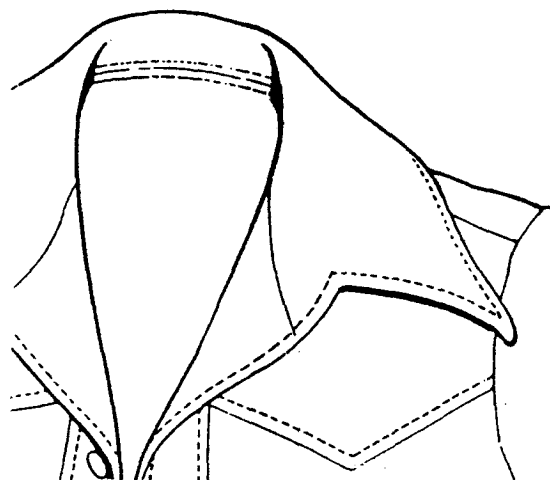

DARNING

SETTINGS

Stitch Length - 8 to 10

Pressure Regulator - 0 (DARN)

Zigzag foot or square automatic buttonhole foot

Stretch fabric between embroidery hoops with hole centered. Lower presser bar and sew at a slow speed moving fabric back and forth with a steady rhythm to cover darning area. When it is covered, turn fabric 1/4 a turn and sew layer of stitching across first layer.

If fabric is thin or badly damaged in hole area, you may want to put a separate piece under the hole for reinforcement.

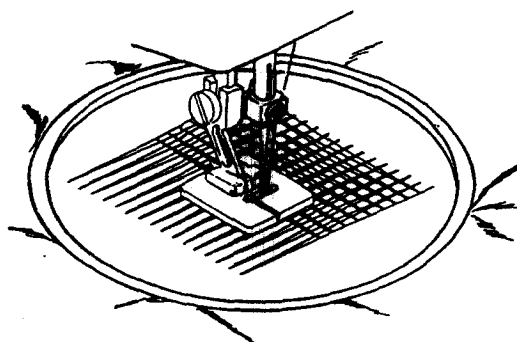

Regular Basting



Free Method



TEMPORARY SEWING BY MACHINE

Regular basting by machine is easy – simply use **straight stitching** with longest available **length** setting. And your machine has a free basting method for very long stitches that sometimes can be used for “marking”.

FREE BASTING METHOD

SETTINGS

Basting switch - turn on
Pressure regulator - 0 (DARN) or 1
Use feed cover plate.

Tap the foot control and the machine will take one stitch and stop automatically with the needle in the up position. Holding the fabric in both hands, pull it back to the required stitch length.

Repeat this process, tapping down on the foot control and guiding the fabric with your hands.

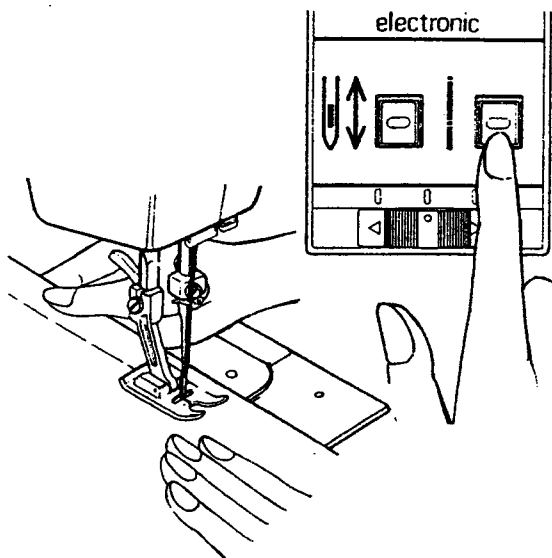

PIN BASTING

You can sew over pins easily (if done **correctly**) because your presser feet are hinged. Pins must be inserted at right angles to seam line. Tip of pin should just **touch** seam line. Sew over **tip** of pins. Pins must **not** come in contact with feed dogs: **Never** pin on the **under-side** of the fabric. Sew slowly. If in doubt about sewing over pins, **remove** each pin as you approach it.

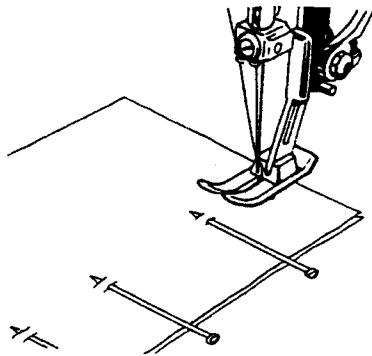

STAY-STITCHING

“**Stay-stitching**” is a form of temporary seaming that prevents stretching of **curved edges** of garments. Usually this is on a **single layer** of fabric, so reduce **top thread tension** slightly to prevent puckering. Baste about **1/4”** away from intended seamline.

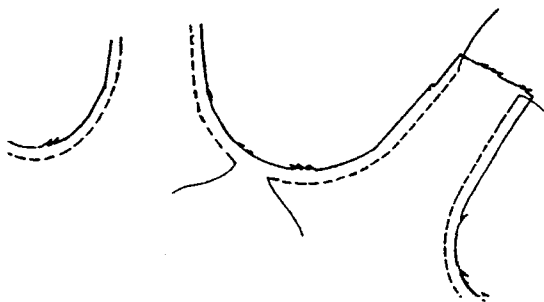

ZIPPER APPLICATION - CORDING

Home-sewn zippers can look as nice as those on expensive ready-mades. We recommend you follow directions given on zipper package. There are two basic types: conventional, and invisible. Your Zipper Foot will assist you with any of these installations. Use these simple settings:

For conventional zippers... Your zipper foot is adjustable for use on right or left side of needle. Adjust foot so needle clears side notch on foot. Then proceed according to zipper manufacturer's instructions.

Invisible zippers are applied to an open seam, to seam allowances only; there is no stitching visible on outside of garment. Adjust zipper foot so needle is sewing through center hole of foot and one groove of foot is riding on teeth of zipper. After zipper insertion, finish by shifting foot to side position and sewing through side notch.

Your zipper foot also makes it easy to add "cording" to garments as well as slip covers, toss pillows, bedspreads, decorative pieces. Cut fabric on bias and wrap around cord. Pin fabric in place so seam edges are even. With zipper foot to left of needle, stitch close to cord.

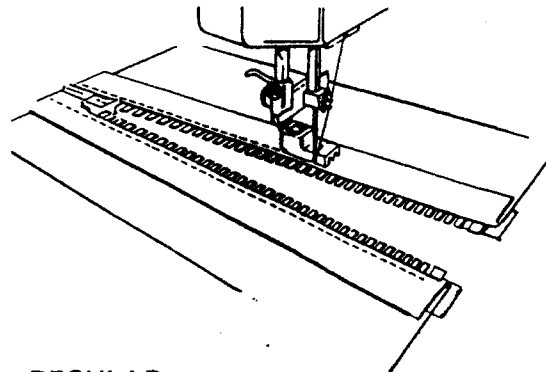

REGULAR
ZIPPER

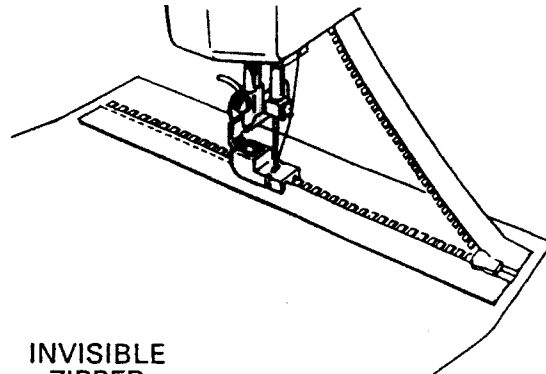

INVISIBLE
ZIPPER

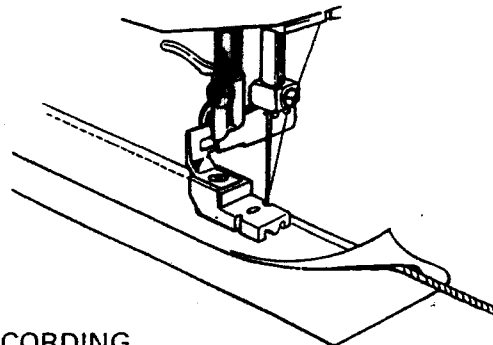

CORDING



NARROW HEMMING

Attach the Narrow Hemmer to the adjustable holder. Make sure that edge of the fabric is cut straight. Turn a tiny double hem ($\frac{1}{8}$ inch) along edge for about two inches. Place end of this hem under Narrow Hemmer. Hold thread taut while stitching along inside edge of hem. Feed fabric gradually into "scroll" in hemmer, guiding edge of fabric as shown.

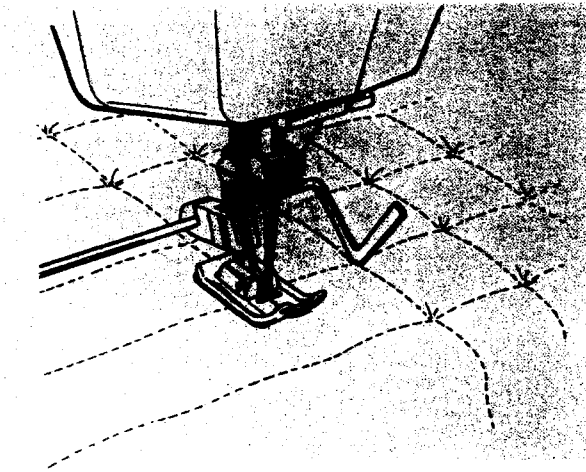

QUILTING

Attach the quilting guide to presser foot as shown. After completing the first row of stitching, place the guiding prong on this stitched line. The second row then can be placed at the desired distance from first row. Continue working in this way for as many rows as you want.

ZIGZAG STITCHING

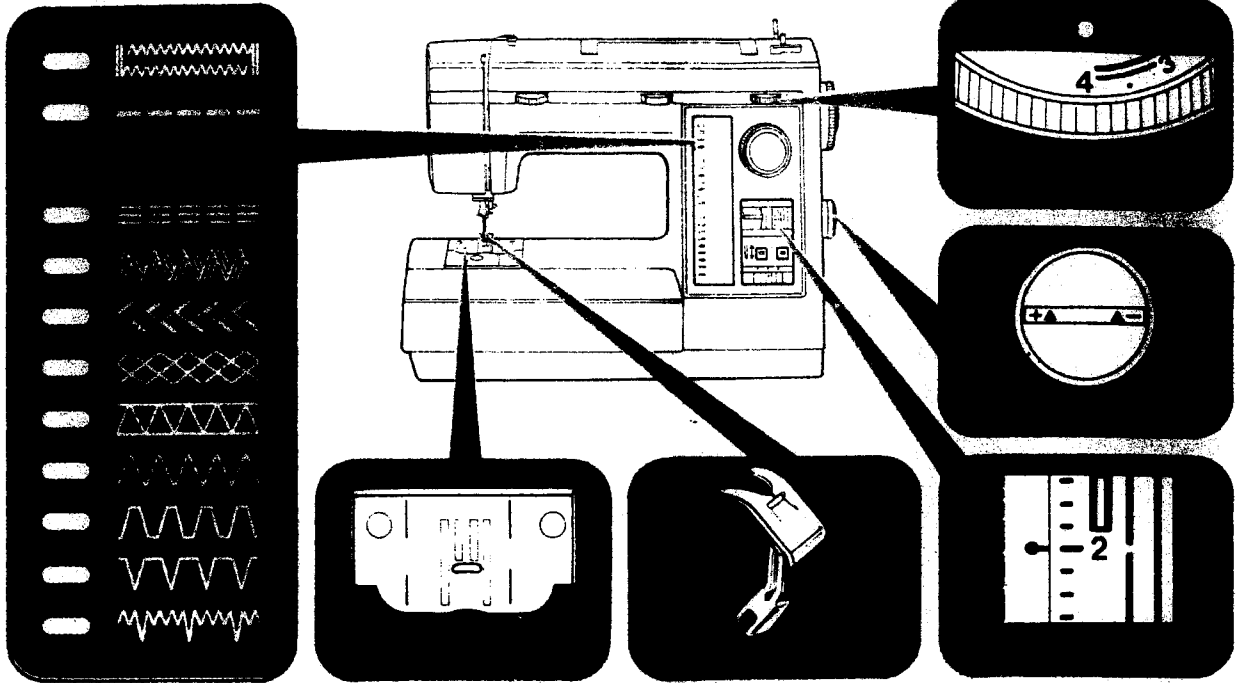

Simple zigzag stitching enables you to do many exciting things with your Kenmore sewing machine. Beyond basics, you'll use zigzag stitching to applique, embroider and monogram. Unlike straight stitches, zigzag stitches have a side-to-side width as well as a

stitch length. You'll find "recipes" for many zigzag operations on following pages. You can create an exciting variety of zigzag stitches by adjusting stitch width and length controls (see chart below).

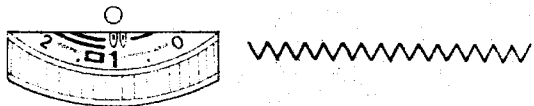

Narrow zigzag for light fabrics, barely shows — set at 1.

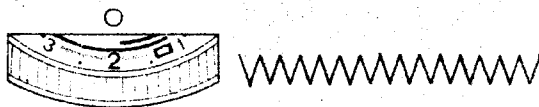

Medium zigzag for most construction seams — set at 2.

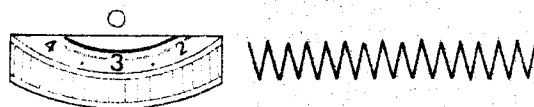

Wide zigzag for double layers, like hemming — set at 3.

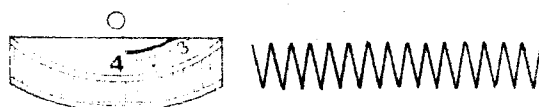

Extra wide zigzag for heavy fabrics or those that fray — set width at 4.

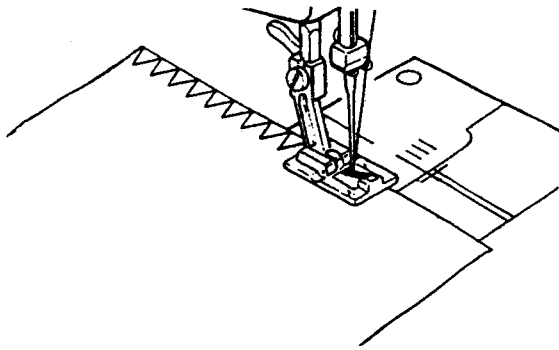

OVERCASTING

Stitch Selector - 
 Stitch Length - 12-8
 Stitch Width - 3-4
 Use Overcast Foot.

This is one of the more frequently used zigzag stitches on garment construction. You may want to overcast along the raw edge of each seam allowance or fold the raw edge toward the garment and stitch.

Stitch so the needle pierces the fabric just short of the outside edge. Raw or worn edges of older garments can be overcast to prevent further raveling.

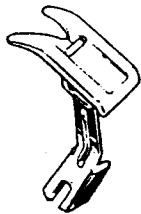

Satin stitch foot

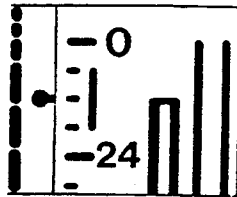

SATIN STITCHING

Stitch Selector - 
 Stitch Length Dial - Between 0 and 24 (—)
 Use metal or plastic Satin stitch foot which is grooved to permit dense stitching to pass under it easily.

Closely spaced zigzag stitches are called satin stitches. This is an attractive stitch used for appliqueing, bar tacking.

Whenever you are using this stitch, it is well to remember to loosen the tension of the top thread slightly. The wider the stitch you make, the looser the tension should be.

If you are stitching on a very soft fabric, use a backing of tissue paper or interfacing for a well formed stitch. Puckering of the material will be eliminated and the bobbin thread will not be visible on the right side of the fabric.

As with all special stitches, it is best to make a sample design on your fabric before starting the design on the garment.



BAR TACKING

Settings same as Satin Stitching

This stitch is similar to a very short satin stitch and is used to reinforce points of strain such as corners of pockets and straps on lingerie.

Sew 4 to 6 zigzag stitches.

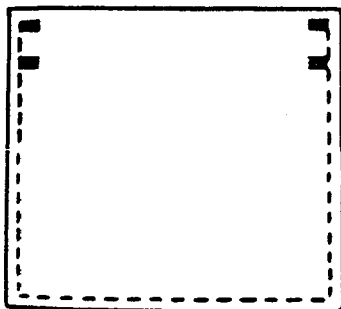

APPLIQUEING

Settings same as Satin Stitching

Select an applique design to be applied to your garment and baste it in place. Satin stitch around the raw edge of the applique completely covering the edge. You may want to do this with a contrasting color of thread.

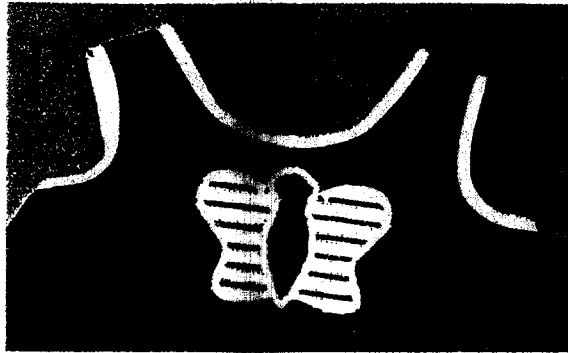

EMBROIDERY

Settings same as Satin Stitching

Satin stitch can be used to produce many different designs and patterns. To sew the flowers illustrated, back the fabric with interfacing or paper and draw on the design with tailor's chalk. Turn the stitch width control from 0-4-0 to from each petal and leaf. Join the flowers and leaves with straight stretch stitch. If using paper, carefully remove it when you have finished sewing.



MONOGRAMMING

Settings same as Satin Stitching

To sew initials, first back the fabric with interfacing or paper. Draw the initials on to the fabric with tailor's chalk. Satin stitch, adjusting the width from 0-4 as you begin and end the stroke of a letter. Or the same stitch width can be used throughout. If using paper, carefully remove it when you have finished sewing.



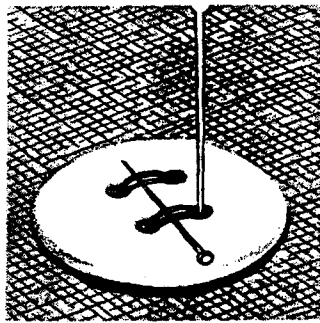
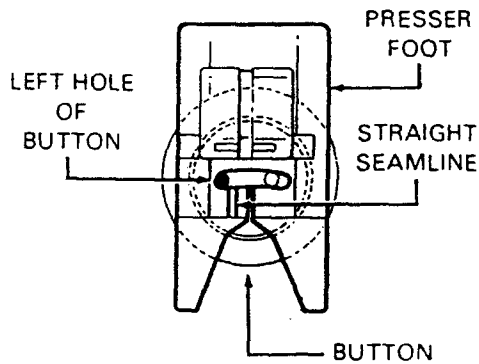
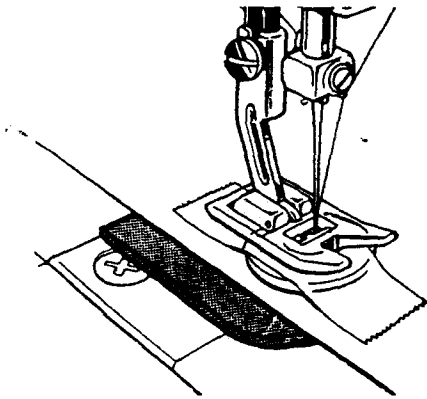

BUTTON SEWING

Stitch Selector - 
 Stitch Width - Adjust to Button Size
 Use Feed Cover Plate and Clear Plastic Satin Stitch Foot.

1. Position the button on fabric with clear tape.
2. Center the left hole of button between straight seamline and the left edge of needle slot of foot and lower foot to hold the button securely.
3. Turn hand wheel manually until needle point is just above button.
4. Adjust stitch width control so needle will enter right hole of the button.
5. Turn hand wheel again by hand so needle enters second hole. Readjust stitch width if necessary. Stitch a number of times.
6. Finish sewing with an extra two inches of thread remaining. Draw these threads to reverse side of garment and tie.

When sewing a flat button, place needle or pin between holes of button as shown to provide flexibility for buttoning.

MENDING AND OVERCAST STITCHING (THREE-STEP ZIGZAG)

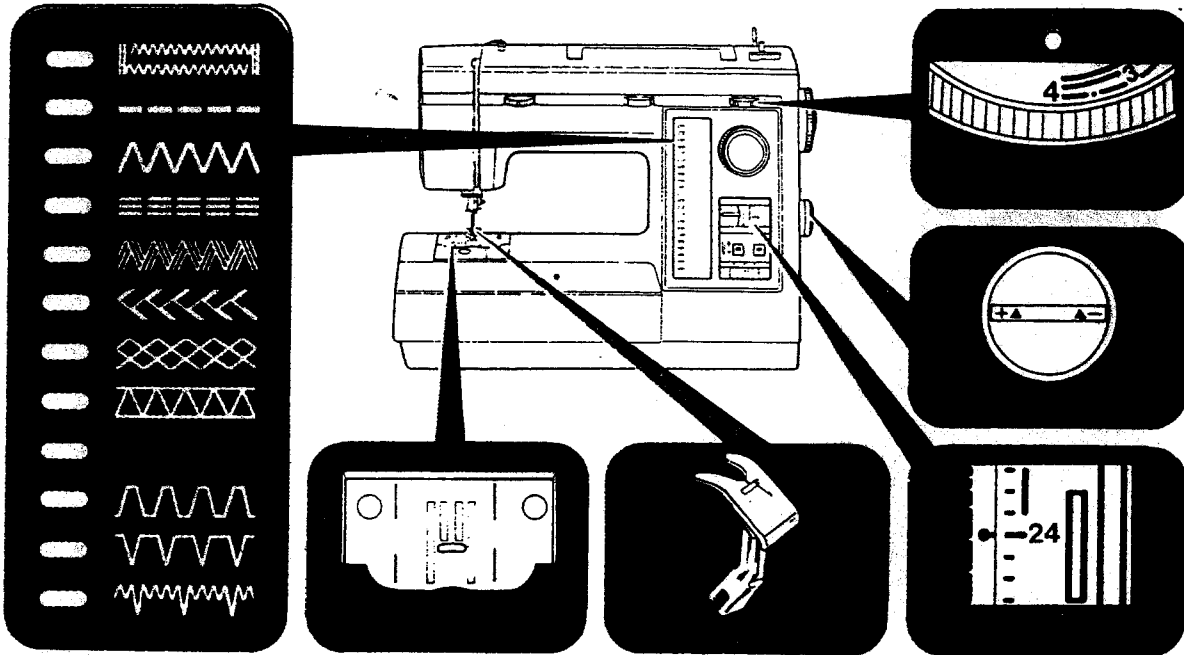

MENDING A TEAR

Stitch Length - 0 - 24
 Stitch Width - 3 - 4

To repair a straight or three-cornered tear, position the tear under the needle in such a way that the stitching catches both sides of the tear. When mending a three-cornered tear, stitch from each end to the center. It is well to use a piece of fabric under the tear for reinforcement.

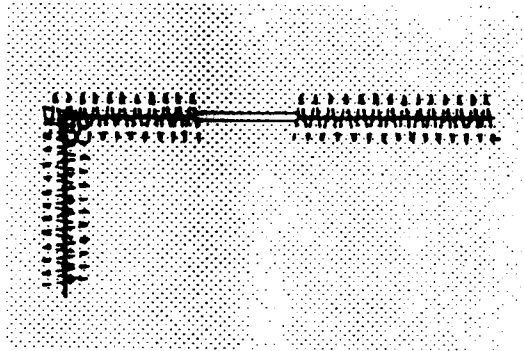

OVERCASTING WITH MENDING STITCH

Stitch Length - 24 - 12
 Stitch Width - 3 - 4

Three-step zig-zag is a strong stitch because, as its name implies, it takes three short stitches where normal zig-zag takes one. For this reason it is highly recommended for overcasting, i. e. finishing a raw edge, on all types of fabric.

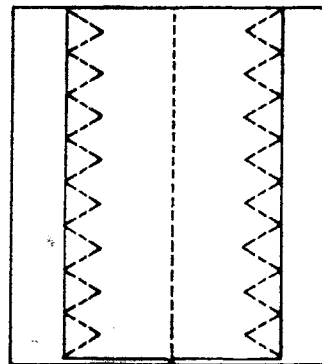

BOX STITCH

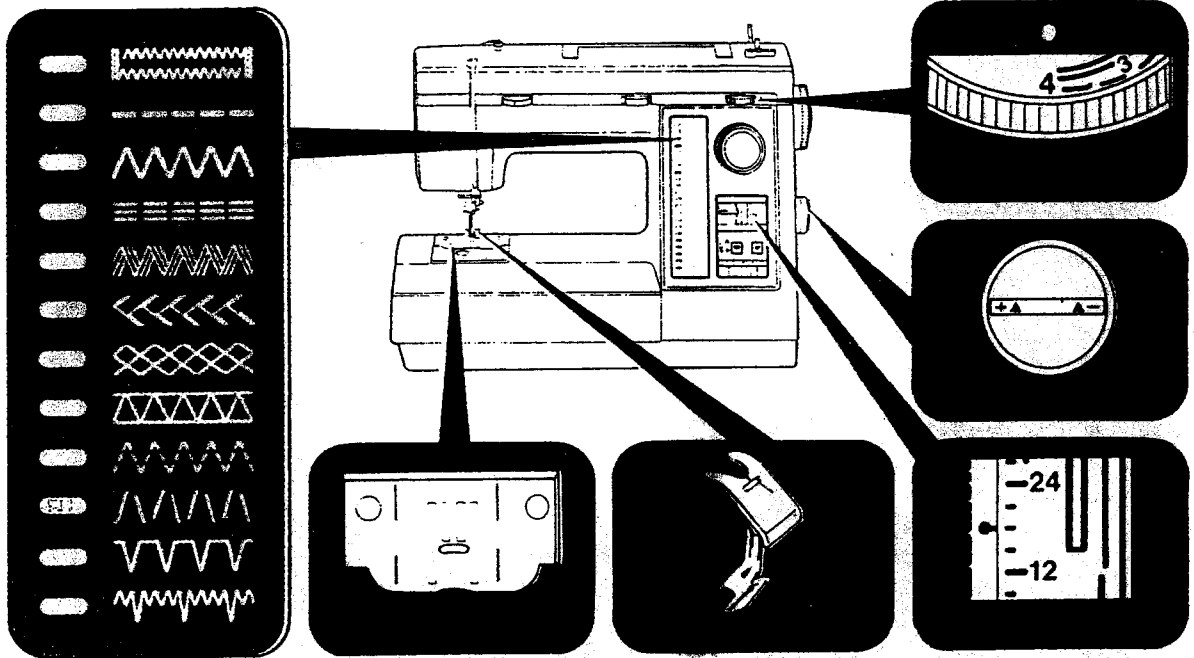

Stitch Length - 24 - 12
 Stitch Width - 2 - 4

OVERLAPPED SEAM

Box stitch is ideal for producing flat overlapped seams on almost any type of fabric and a bolder effect will result from sewing with a contrasting thread.

Overlap the raw edges of two pieces of fabric 2" and pin or tack. Place the fabric right side up with the middle of the overlap under the center of the presser foot, so that the stitch sews just over the top and bottom raw edges.

DECORATIVE EDGING

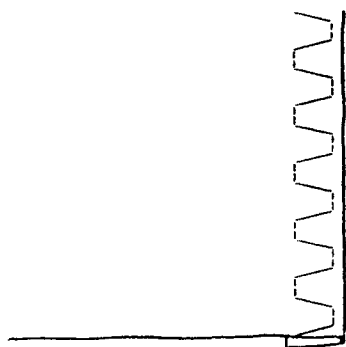
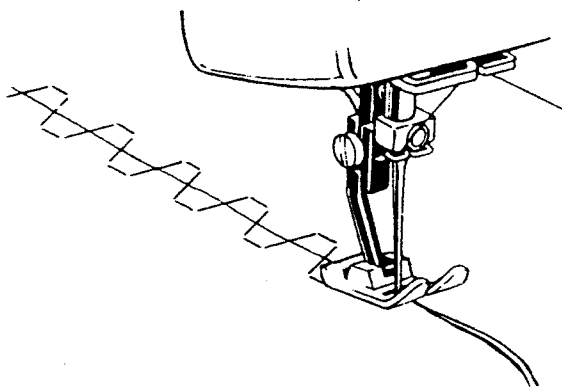

Turn the raw edge under 2" and press. Place the fabric right side up with the middle of the turnover under the center of the presser foot, so that the stitch sews on to the fold and just over the raw edge underneath.

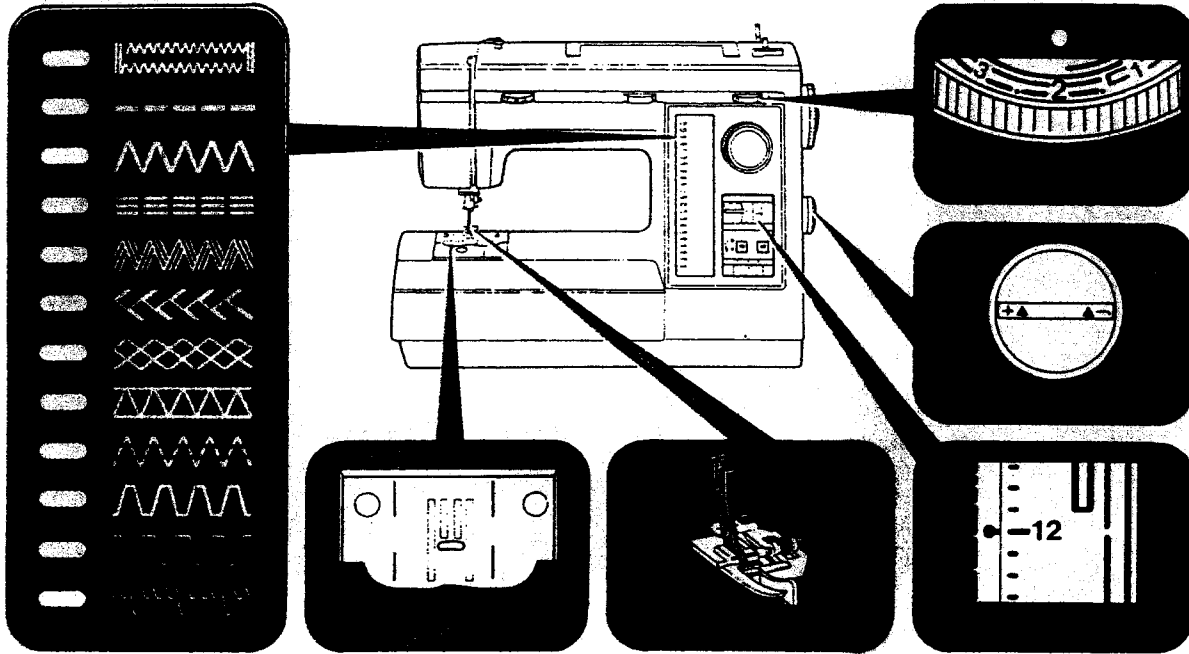

BLIND HEMMING



Blind hemming is a good technique to use on garments, and especially on curtains and drapery hems so that stitches need not show on the front of the fabric. Because your Kenmore has two types of blindstitches built in, blind hemming is easier than you'd expect. It's just a matter of folding... give it a try!

- 
 — Regular blind stitch for normal fabrics
- 
 — Elastic blind stitch for soft, stretchable fabrics

PROCEDURE

Stitch Length - 12
 Stitch Width - 1½ - 2

Finish raw edge of fabric appropriately. You may want to use seam tape on woven fabrics. With knits use a lace seam tape or just use decorative stretch stitch.

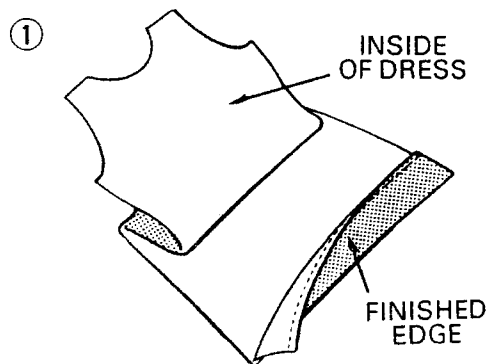

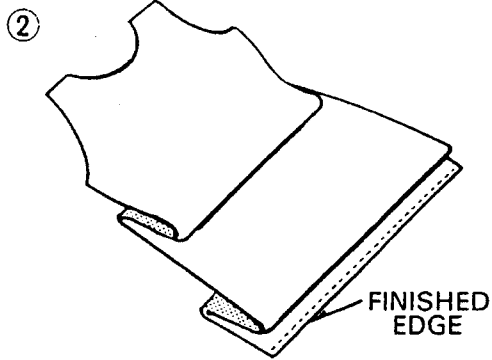

Working on wrong side of fabric, fold hem up. Press and pin in place. Then fold hem allowance under... leaving $\frac{1}{8}$ " of hem edge extending.

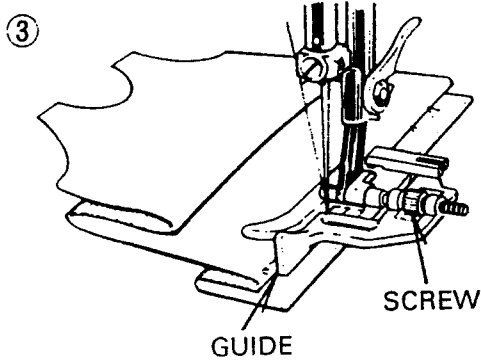

Place garment under blind stitch foot with the fold of the garment against guide and slide it by turning screw so that the zigzag just catches the fold. (Blind hemming can be simplified by also using the special Kenmore Edgestitcher - please refer to p. 21 for details.)

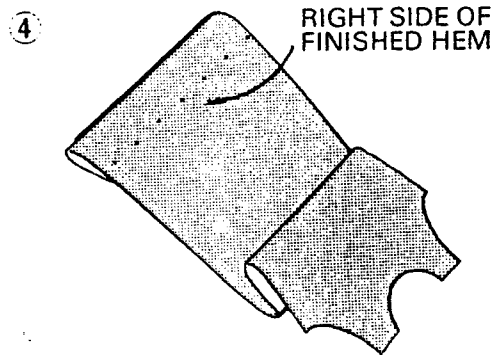

Now the right side of your garment will show only the blind stitches! Be sure to press both sides of the finished hem!

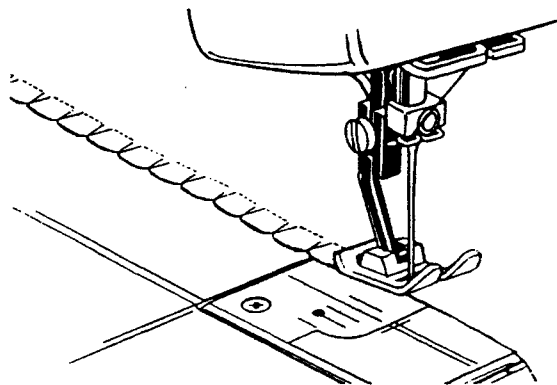

SHELL STITCHING with blind hem pattern

Stitch Length - 12
Stitch Width - 2 - 4

This shell-stitched edge is a popular finish for lingerie and nightgowns. To achieve this multiple scalloped effect, allow needle to clear just the left edge of the fabric when it zigzags.

SCALLOP STITCH

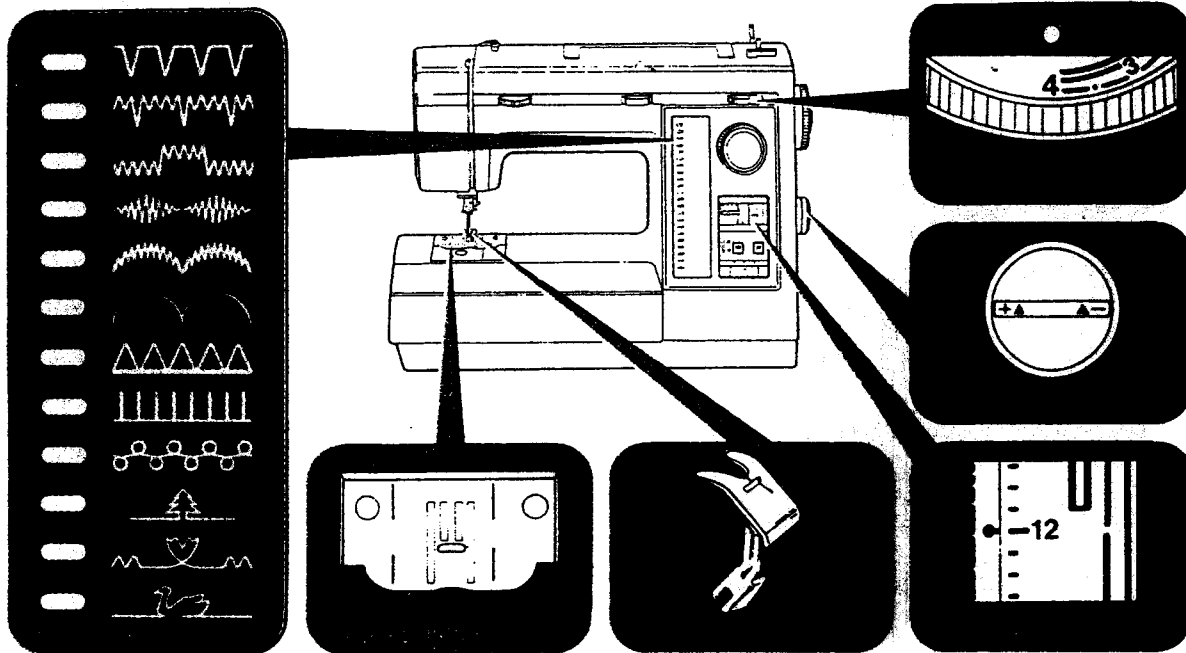

PROCEDURE

1. With right sides of fabric together, sew near the folded edge with scallop stitch.
2. Trim allowance to 1/8" or less. Notch curves if necessary. Cut down into points.
3. Turn to right side and push scallops out evenly. If they do not seem even, be sure curves are notched similarly. Fig. 2.
4. Press flat.

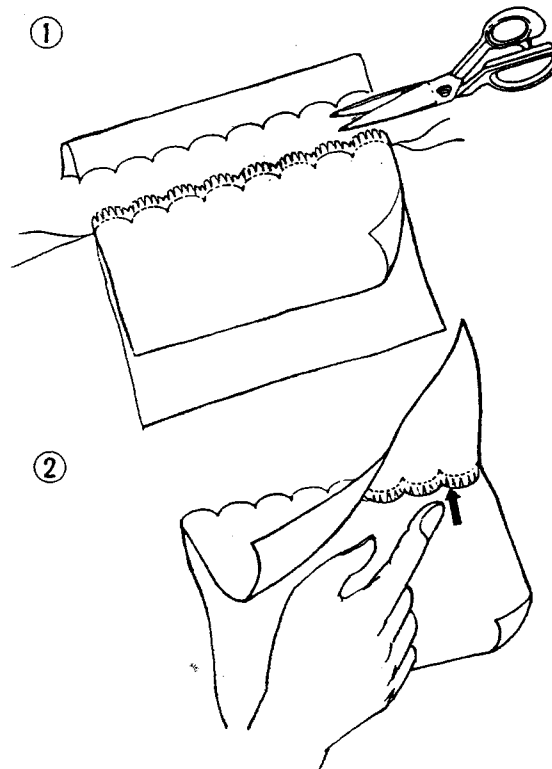

STRETCH STITCHES

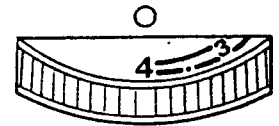
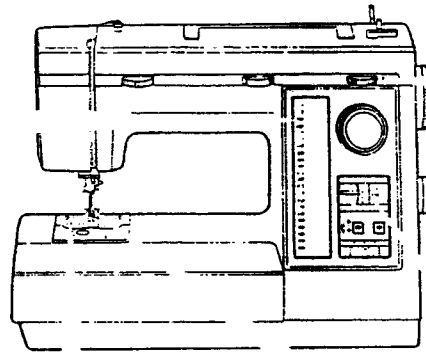
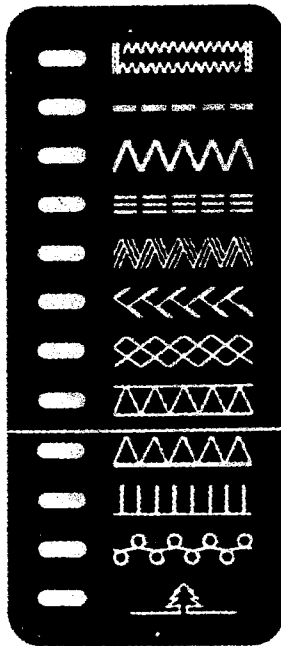

1 - 4

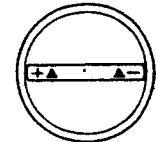

See next page.

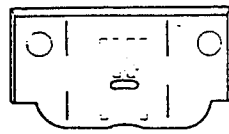

Zigzag needle plate

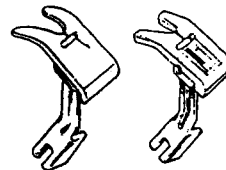

Zigzag or Q foot

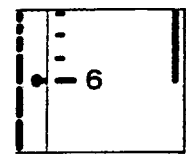

Within yellow zone

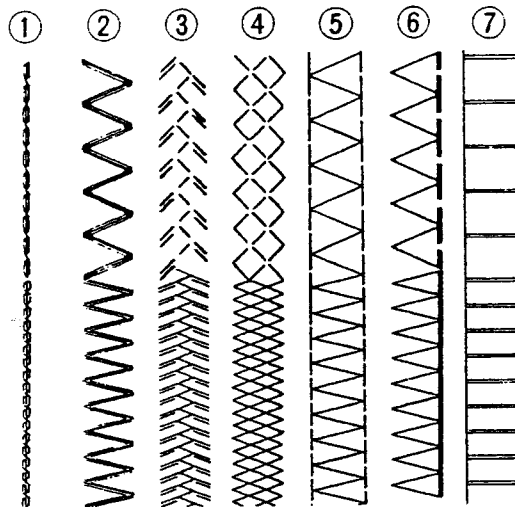

Stretch stitches, as their names imply, are mainly for use on stretch and knit fabrics such as stretch nylon, stretch towelling, jersey and cotton jersey; and for sewing together knitted garments. Stretch stitches are also often used on non-stretch fabrics.

1. Straight stretch
2. Rick-rack stretch
3. Feather stretch
4. Smocking stretch
5. Elastic stretch
6. Overcast stretch
7. Paris point stretch

ADJUSTING STITCH LENGTH

Depending upon your preference in stitch patterns, you may make stretch stitches closer together without changing the balance of stitches by turning stitch length control to lower numbers within yellow zone.

ADJUSTING STRETCH STITCH BALANCE

Stitch modifier should be in neutral (notched) position for most materials. Depending upon the type of fabric used, you may need to adjust this control to match forward stitches of stretch sewing with reverse motion stitches. If the stitches are too open, turn the control slightly clockwise; if the stitches overlap, turn the control counter-clockwise.

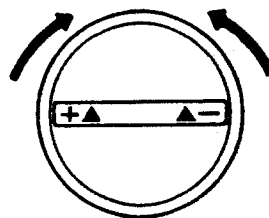

RECOMMENDATION

1. It is recommended you use the Q set for sewing knit and woven synthetic fabrics.
2. It may be necessary to use an interfacing or backing when sewing very soft and thin knits or woven synthetic fabrics.

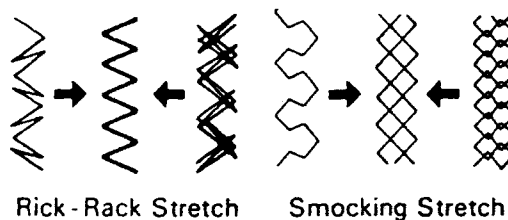

STRAIGHT STRETCH STITCH

SETTINGS

Stitch Selector - ≡≡≡≡≡≡

Stitch Length - Yellow Zone

Stitch Width - Any number (not necessary to adjust)

You may use either a zig zag or straight stitch foot BUT-- for best control of fabric, best looking straight stitches and best feeding of fabric use **Straight Stitch Foot** and **Straight Stitch Needle Plate**.

Use this stretch stitch with knit or synthetic fabric. Sew as you do with regular straight stitch.

This is also a good stitch to use on curved seams regardless of the type of fabric. Any seam that will receive a great deal of strain when worn should be sewn with the stretch stitch. Use in children's shorts and slacks as well as adult sports clothes.

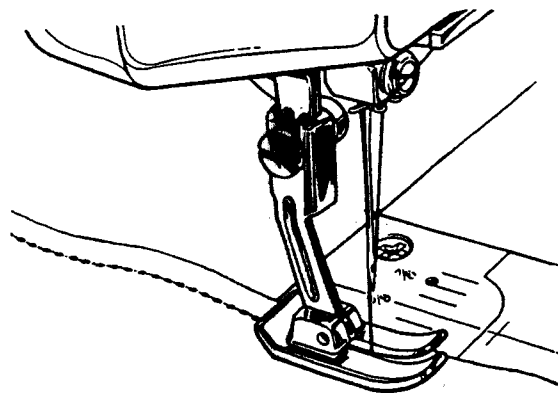

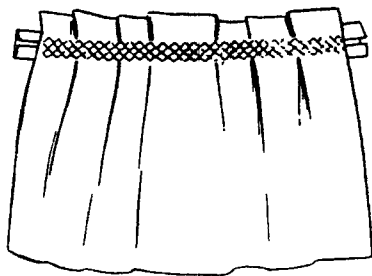
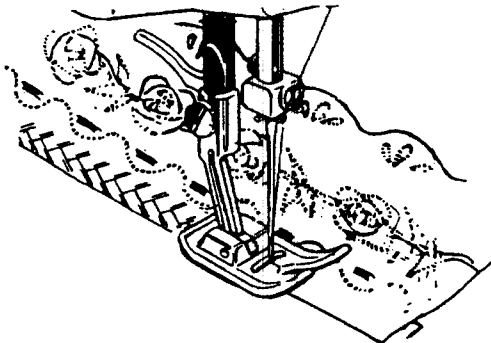
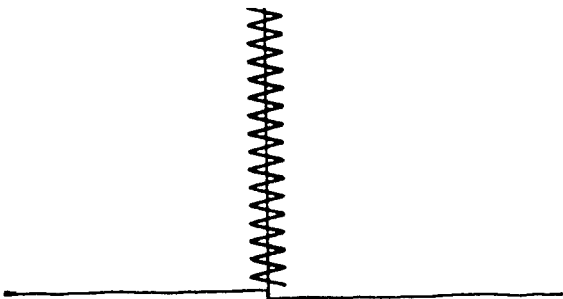
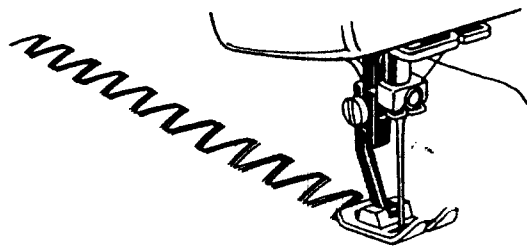

RICK-RACK STRETCH STITCH

Stitch Selector - 
 Stitch Length - Yellow Zone
 Stitch Width - Yellow Zone

Sew on stretch fabrics in any area that you might use a zig zag stitch. This stitch can be used as a decorative top stitch as well.

It is useful also on lapped or abutted seams where you lap one edge of a seam over another with seamlines meeting in the center.

FEATHER STRETCH STITCH

Stitch Selector - 
 Stitch Length - Yellow Zone
 Stitch Width - 2 - 4

This is a good stitch to use with laces, on lingerie, bra and girdles; and to apply bias tape. It's great when quilting.

SMOCKING STRETCH STITCH

Stitch Selector - 
 Stitch Length - Yellow Zone
 Stitch Width - 2 - 4

1. Make a straight line of gathers across the fabric that you wish to smock.
2. With a narrow strip of fabric directly under the line of gathering, stitch over the gathers. The design will be a series of small diamonds.

Note: When smocking a garment, the stitching should be done before the piece is sewn into the garment.

ELASTIC STRETCH STITCH

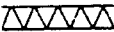
Stitch Selector - 
Stitch Length - Yellow Zone
Stitch Width - 2 - 4

Use this versatile stitch to insert elastic in garments. Simply stitch elastic into place, making sure it is evenly spaced. To do this, mark the correct length piece into quarters, then match these markings with center front and side seams.

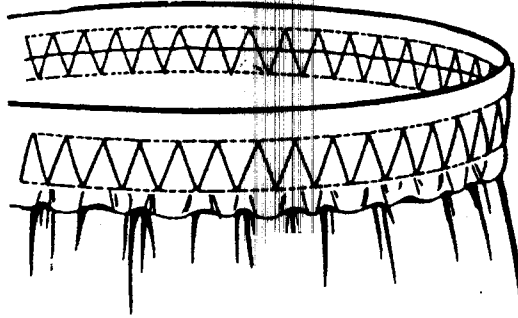

OVERCAST STRETCH STITCH

Stitch Selector - 
Stitch Length - Yellow Zone
Stitch Width - 4

This is the same type stitch used by the garment industry in making sportswear-it forms and finishes the seam in one operation (for seams of $\frac{1}{4}$ " to $\frac{3}{8}$ "). It's very effective for use in repairing raw or worn edges of older garments.

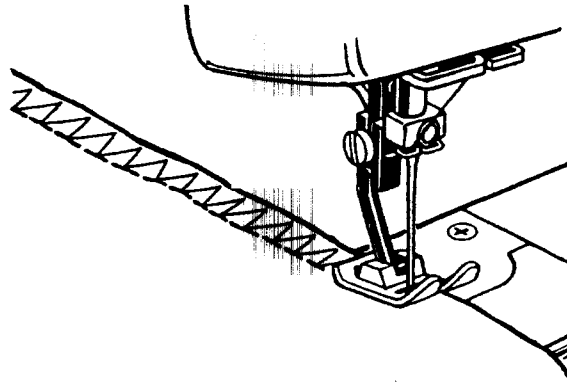

PARIS POINT STRETCH STITCH

Stitch Selector - 
Stitch Length - 12
Stitch Width - 2 - 3

Excellent for hemstitching table and bed covers with a elegant touch. Picot-like stitch can also be made on sheer materials. Sew along the raw edge of fabric and trim close to the outside of the stitching.

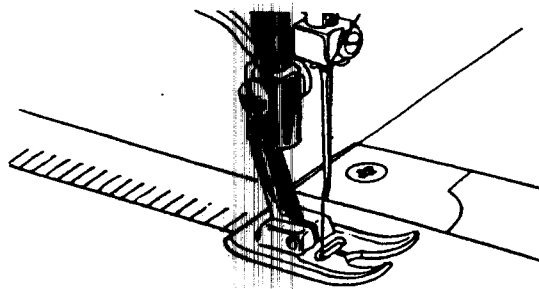

GETTING THE MOST FROM FABRICS THAT GIVE

Some stretchy suggestions...

Be sure to use the Q SET™ with knits and any synthetic woven fabric — and zigzag or satin foot as required.







Loosely constructed knits sometimes catch over toes of presser foot. To remedy this, wrap short strip of transparent tape around the foot encasing both toes.

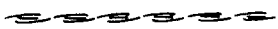

To avoid tangled threads when working with knits, start seams carefully. Position fabric

and lower needle before lowering presser foot.

It is always a good idea to test thread tension and stitches on a scrap of the fabric being used.

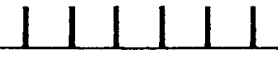
Knits contain more yarn than woven fabrics, so you will need to take greater care to keep your machine clean specially in feed dog and bobbin case area.

WHERE TO USE WHICH STRETCH STITCH: A CHECK-CHART	
Specially for Stretch	
 STRAIGHT STRETCH	Use on stretch and knit fabrics and to repair ready made garments at stress points. Basic stitch for all garment seams requiring "give" (i. e. armholes, crotch area, etc.). Use also to sew center seam of men's neck ties and seams cut on the bias.
 RICK – RACK STRETCH	A basic multi-purpose stretch stitch with same usage as zigzag stitch, especially for lightweight stretch fabrics.
 FEATHER STRETCH	Use with laces, on lingerie, bra and girdles; and to apply bias tape. It's great when quilting.
 SMOCKING STRETCH	A decorative stitch for use on children's clothing, lingerie, yokes of blouses, dress bodice.
 ELASTIC STRETCH	Use to apply elastic to top of lingerie or to repair ready-made lingerie and replace or restitch elastic.
 OVERCAST STRETCH	Use on sportswear where 1/2" seams are required. Makes and finishes seams at same time.
 PARIS POINT STRETCH	Use for hemstitching and seam finishes. Also for applique and other decorative elastic blind hem, hem on knits.

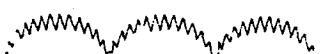
"Everyday" Stitches with Stretch Applications	
 PLAIN ZIGZAG	Use for all-purpose stretch sewing, seam finishing, edge finishing, or attaching stretch laces.
 BLIND HEM	A good shell stitch for nylon tricot lingerie.
 CRESCENT STITCH	Can be use for attaching girdle panels and applying stretch laces.

HINTS ON SEWING DIFFERENT FABRICS

The chart below provides many details but you'll also want to remember...

- Soft fabrics may need backing — especially where stitches are close together.
- In sewing knits, if you can't match fabric and thread exactly, use the strongest fine thread available and use a Q NEEDLE.

- When working on tweed — or other multi-colored bulky fabrics — use one color thread on bobbin, another on top. (Great for repairs — the "patch" practically disappears!)

FABRICS	USEFUL STITCHES TO USE	SPECIAL NOTIONS TO USE
NYLON TRICOT	Overcast Stretch Feather Stitch Elastic Stretch Blind Hem Mending Stitch Crescent Stitch Paris Point Stretch Elastic Blind Hem	Q NEEDLE™ Polyester, nylon or dacron core thread Q FOOT™
TERRY CLOTH REGULAR CORDUROY	Simple Zigzag Mending Stitch Paris Point Stretch	Mercerized Thread Size 14 needle
TERRY CLOTH STRETCH	Simple Zigzag Mending Stitch Overcast Stretch	Mercerized Thread Polyester, nylon or dacron core thread Q NEEDLE™ Q FOOT™
LEATHER	Straight or simple Zigzag	Mercerized or silk thread Size 14 needle ½ pressure on presser foot Even feed foot
STRETCH KNITS FOR SWIMWEAR AND SKIWEAR OR GIRDLES	Overcast Stretch Crescent Stitch Elastic Stretch Mending Stitch Feather Stitch Scallop Stitch Elastic Blind Hem	Polyester, nylon or dacron core thread Q NEEDLE™ Q FOOT™ Lace seam tape Pre-shrunk zippers

BUTTONHOLE MAKING

Your Kenmore brings you two buttonhole systems along with several special accessories that enable you to solve all your clothes "closing" problems.

Your built-in system enables you to sew buttonholes with finished ends (bar-tacked) by simply turning the stitch selector. Only two control settings are required. An important aid is the buttonhole guide foot.

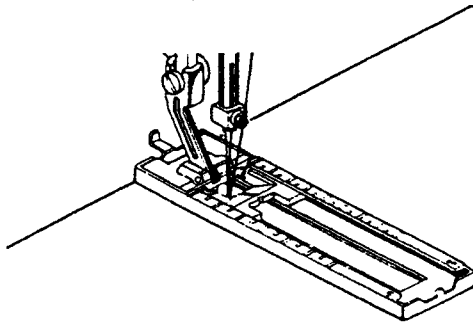

Built-in system

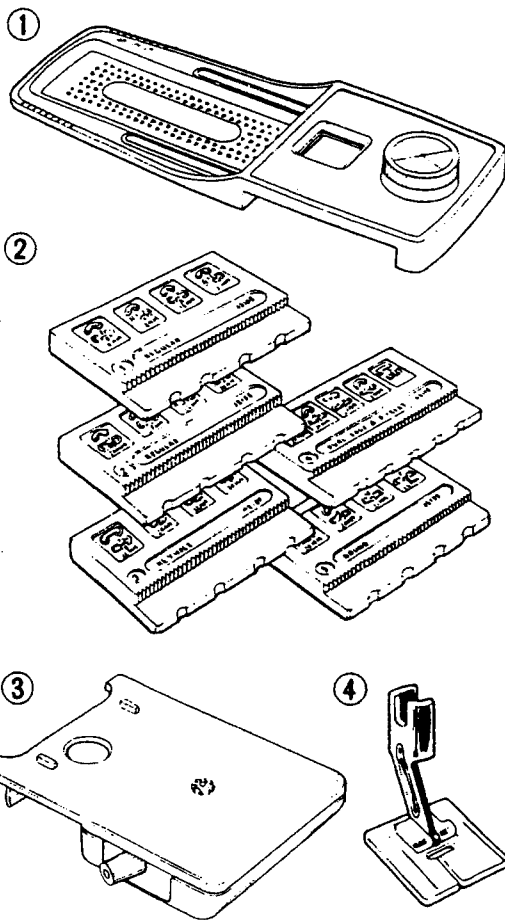

Buttonhole attachment

Your **buttonhole attachment** is a Kenmore "special" that guides the fabric for you, eliminates the need to turn fabric by hand.

You will find following parts in your accessory box:

1. Buttonhole guide plate.
2. Five templates which give you a choice of buttonhole styles and lengths.
3. Cover plate with pinion gear.
4. Buttonhole foot.

TIPS ON BUTTONHOLING

Always make a practice buttonhole on a scrap of fabric you plan to use. Try the buttonhole with the button you will use.

Always use an interfacing in area of garment where buttonholes are placed. Tissue paper or regular interfacing can be used. Tear paper away after stitching, if it is used.

- For heavier weight fabrics, loosen your top thread tension slightly.

BUTTONHOLE MAKING - BUILT-IN SYSTEM

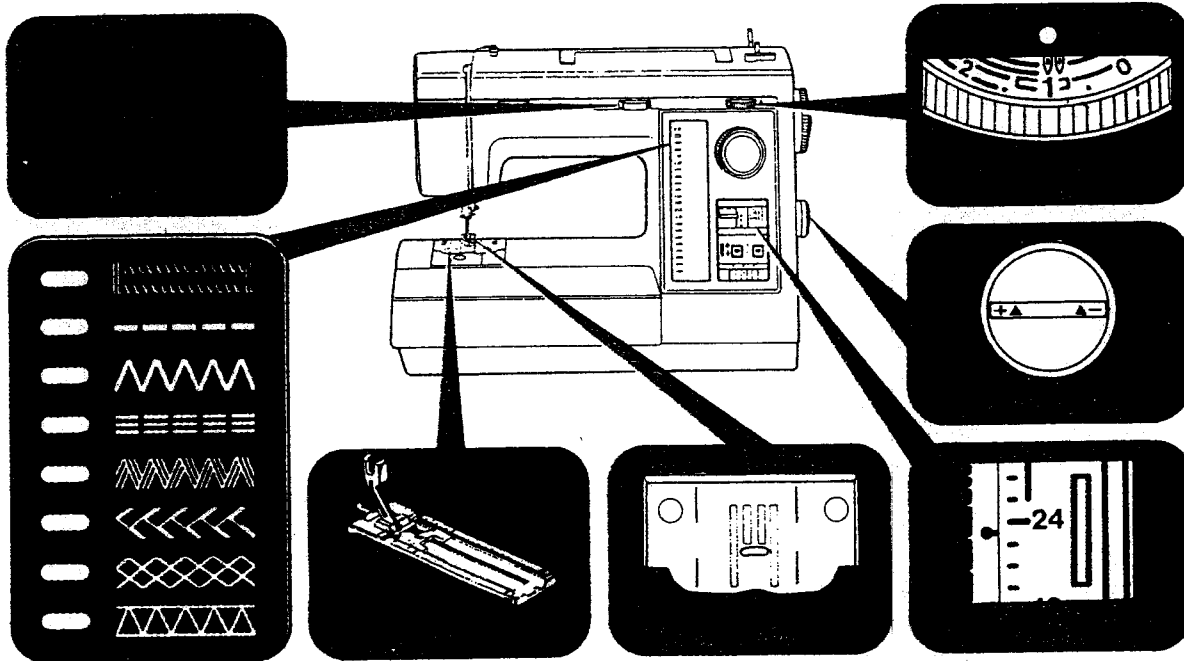

PREPARATION

Carefully mark the buttonhole length on your garment. Place the fabric with the buttonhole marked under the buttonhole foot. Pull the guide foot (A) all the way forward so that the index mark (B) is aligned with the graduation (C), with thread to rear. (Reproduction of the identical size buttonholes is facilitated with the aid of the graduations on the both sides of the buttonhole guide foot. These graduations are 1/8" (left side) or 2.5 mm (right side) apart. Graduations act as reference mark.)

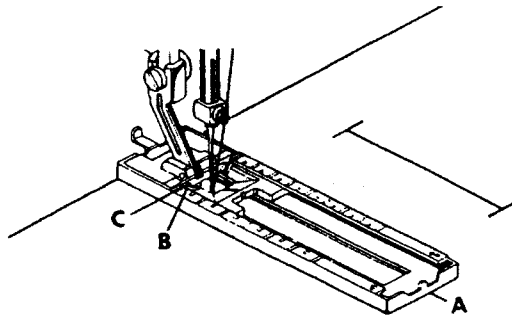

PROCEDURE

1. Switch the control to left. (If it has been already at left, set it at right, sew several stitches and switch to left again.) Step on foot control to form first bartack and left side of buttonhole.
2. When you reach end of left side, switch the control to the right and complete the buttonhole.

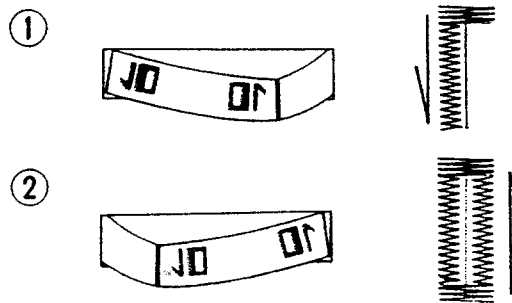

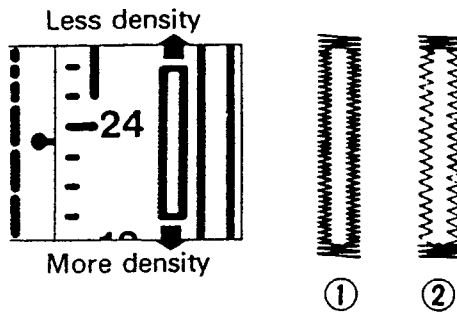

ADJUSTING STITCH DENSITY

Depending upon the fabrics on which you are sewing, or your own preference in buttonholes, you may alter buttonhole stitch density by varying the original stitch length setting within the green buttonhole zone.

1. For more density, turn the dial toward "0".
2. For less density, turn the dial toward "12".

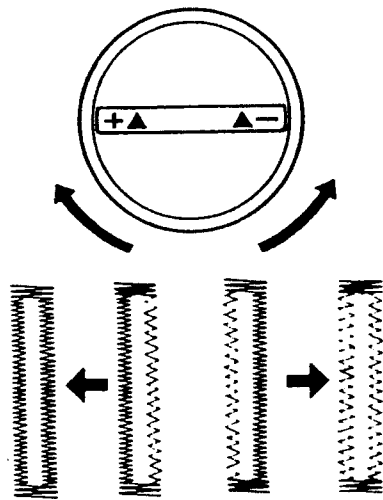

ADJUSTING STITCH BALANCE

Stitch length differences in forward and reverse stitches of the buttonhole are equalized with the stitch modifier.

If the reverse stitches are too far apart, turn the modifier slightly clockwise; if they are too close together, turn counter-clockwise.

CORDED BUTTONHOLES

Hook filler cord (crotchet thread or buttonhole twist) to the spur (A), pull both ends of cord forward under foot and tie to the spur (B). Sew buttonhole in such a way that zigzag stitches cover the cord.

When stitching is completed, release cord from foot, pull ends of cord and snip off extra length.

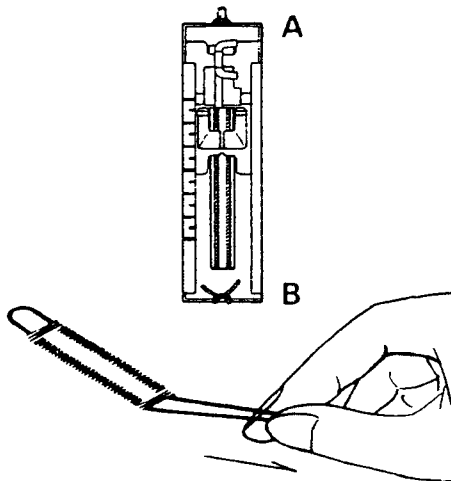

BUTTONHOLE MAKING - USING BUTTONHOLE ATTACHMENT

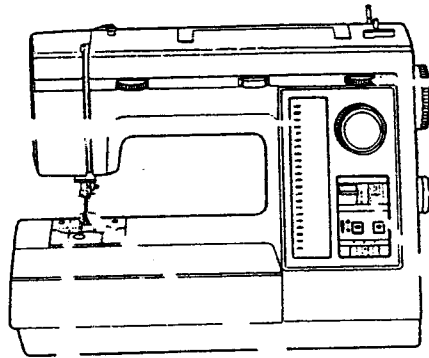
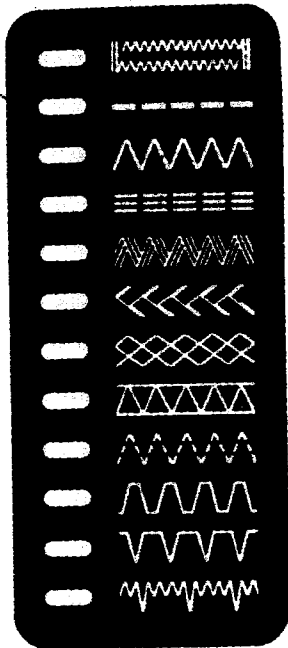

1 - 1/2

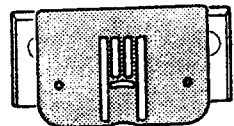
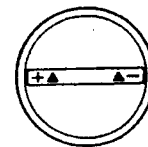

Zigzag needle plate and feed cover plate

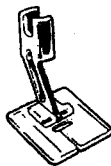

Buttonhole foot

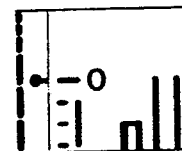

Any setting

REGULAR WORKED BUTTONHOLE (STRAIGHT, KEYHOLE AND EYE-LET)

PROCEDURE

Stitch Selector - 
 Stitch Width - 1 - 1/2
 Zigzag Needle Plate
 Feed Cover Plate
 Buttonhole Foot

1. Raise needle to its highest position and raise presser foot. Remove accessory box and bobbin cover plate.

Insert buttonhole cover plate at **45 degree angle** and snap it down into place pressing it against the needle plate.

2. Select correct template for type buttonhole you want. Insert template into slot of guide plate. Turn template advance knob until desired size appears in window on the top side of guide plate.

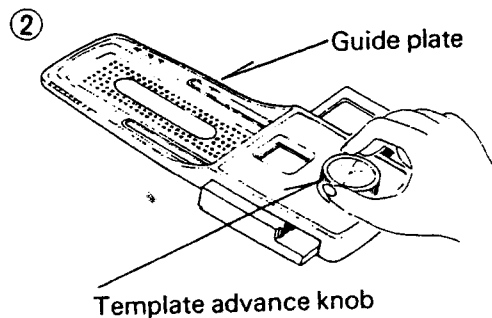
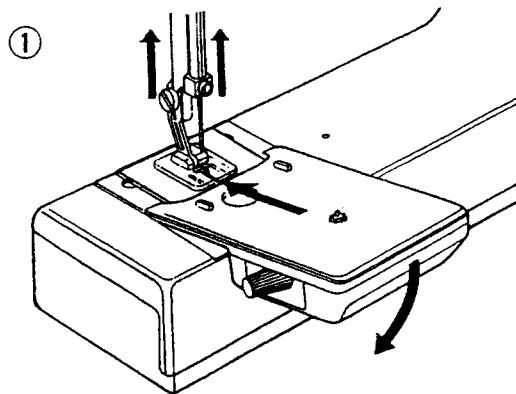

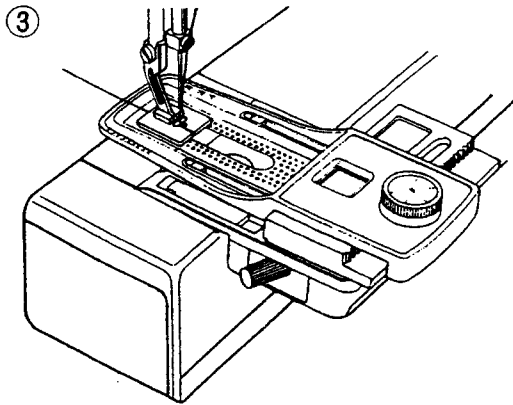

3. Slip guide plate onto machine so it fits in place with **pinion gear** in the center of **arc hole** of template. Be sure guide block is inserted in guide slot.

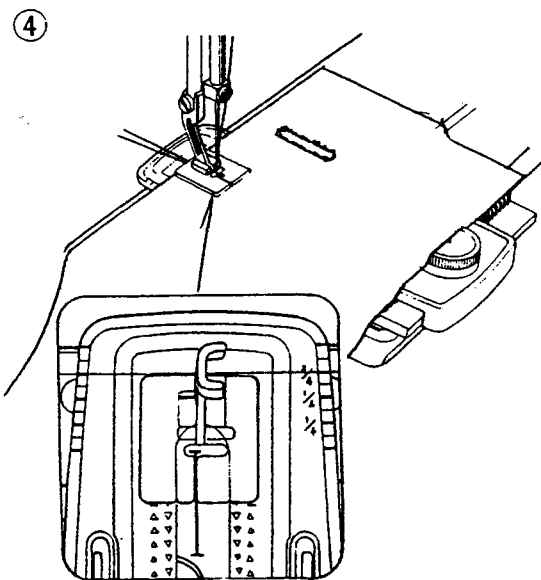
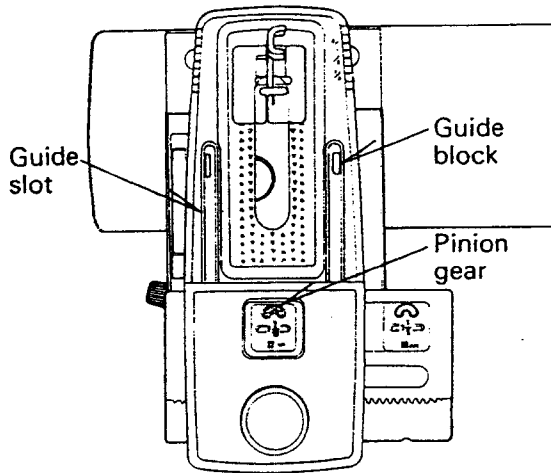

4. Pick up bobbin thread through guide plate by turning hand wheel. Place fabric between presser foot and guideplate. Align marked buttonhole with **cut-out** of foot. Line up edge of fabric with markings on guideplate. If you wish all buttonholes to be 3/4" from edge of garment, for example, line up fabric with 3/4" marking each time you start a buttonhole.

Now you're ready to stitch the shape you've selected—straight, keyhole or eyelet. Your template will guide you.

PURL-EDGE BUTTONHOLE

To add a professional touch to your sewing you will want to make purl edged buttonholes. These are obtained by sewing a wide buttonhole over a narrow stitched buttonhole.

Choose the correct size for your button, insert the template into the guide plate turning to the **narrower** of the sizes. Use the same settings as for regular buttonhole and adjust **stitch width control to 1**.

Drop the guide plate over the pinion gear and sew around the buttonhole once. (STEP 1)

To sew wider outer buttonhole, lift the guide plate from the pinion gear and turn the template to **wider** size. Adjust **stitch width setting to 1.5**, and sew around buttonhole again. (STEP 2)



STEP 1

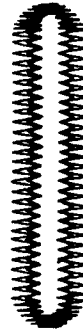

STEP 2

ADJUSTING STITCH DENSITY

Depending upon the fabrics on which you are sewing, or your own preference in buttonholes, you may alter buttonhole stitch density by turning stitch density control knob.

1. For more density, turn the knob toward you.
2. For less density, turn the knob away from you.

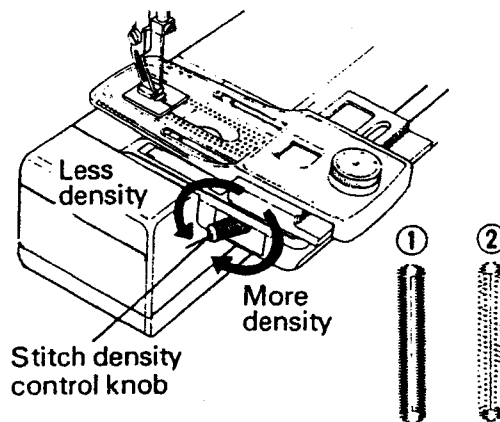

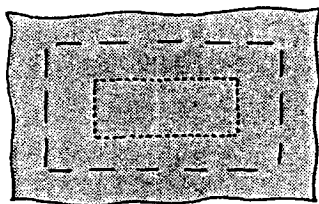
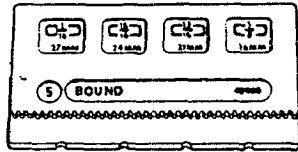

Fig. 1

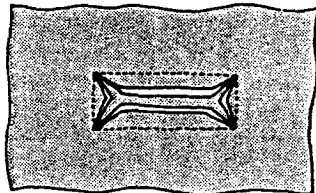

Fig. 2

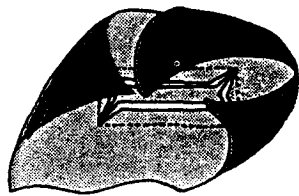

Fig. 3

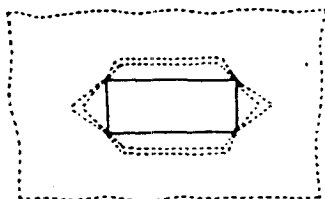

Fig. 4

BOUND BUTTONHOLE

A template had been provided so that you may sew perfectly sized rectangles each time you make a bound buttonhole. Just follow the directions given below.

SETTING

Stitch Width - 0 or Stitch Selector - - - - -

Pressure Regulator - 1 or 2

Other settings same as regular worked buttonhole

1. Space buttonholes on garment-mark length on right side of fabric with pins. Place patch of fabric over each buttonhole and mark ends of buttonhole with chalk or pencil. Baste patch into place. Using template similar in size to buttonhole, stitch rectangle on patch and garment. Do not sew over pins. (Fig. 1)
2. Slash through patch and garment to within 1/4" of ends of rectangle. Carefully cut diagonally into corners as shown. (Fig. 2)
3. Turn patch to wrong side through slash. Press as shown. (Fig. 3, 4)

4. Fold patch forming lips of buttonhole.
Press and baste lips together. (Fig. 5)

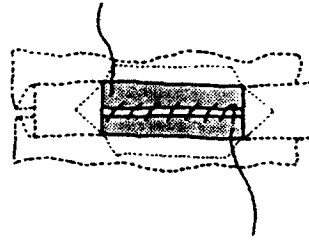

Fig. 5

5. Stitch across pleats formed by lips of patch. (Fig. 6)

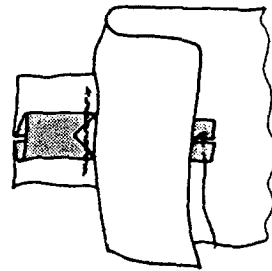
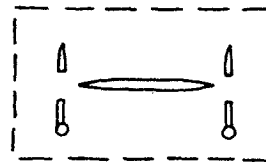

Fig. 6

6. After buttonhole has been pressed, baste facing of garment around buttonhole and slash opening in facing same length as buttonhole. (Mark ends of buttonhole with pins for guides). Turn under facing edges and hem to buttonhole carefully. (Fig. 7, 8)

FACING SIDE



Slash Opening in Facing

Fig. 7

FACING SIDE

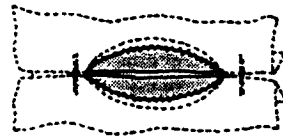

Hem to Buttonhole

Fig. 8

7. Remove all bastings and press. (Fig. 9)

RIGHT SIDE



Complete Bound Buttonhole

Fig. 9

CHOOSING BUTTONHOLE STYLE AND SIZE

Each buttonholing situation will be different so you will want to experiment with your garment, considering fabric and placement of button. Here are some basic applications:

Built-in buttonholes (described previously) are ideal for one or two buttons used on waistband or cuff, or for "belt slots."



Straight buttonholes are most popular for everyday sewing – for series of buttons on dress, blouse, vest, jacket or coat.

Keyhole buttonholes are a variation of the above, with an enlarged opening at one end to allow more room for button shank. These are normally used in tailored vests, jackets, coats.

Eyelet buttonholes (another variation of "straight") most often are used for studs on skirts or holes for tongues of belt buckles.

Purl-edge buttonholes are made by stitching a larger straight buttonhole on top of a narrow one – for a unique look.

Bound buttonholes – made with extra fabric "hemming" the hole – provide "professional look" to dresses, jackets, coats and for contrasting, decorative buttonholes.

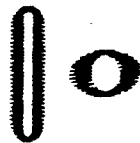
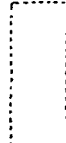
Template	Straight buttonhole	Keyhole buttonhole	Purl-edge and eyelet buttonhole	Bound buttonhole
				
45195	$\frac{3}{8}$ " - $\frac{1}{2}$ " - $\frac{5}{8}$ " - $\frac{13}{16}$ "			
45196	$\frac{15}{16}$ " - $1\frac{1}{16}$ " - $1\frac{1}{4}$ " - $1\frac{1}{2}$ "			
45197		$\frac{7}{8}$ " - $1\frac{1}{16}$ " - $1\frac{1}{4}$ " - $1\frac{3}{8}$ "		
45198			$\frac{13}{16}$ " - $1\frac{1}{16}$ " - Eyelet	
45199				$\frac{15}{16}$ " - $1\frac{1}{16}$ " - $\frac{13}{16}$ " - $\frac{5}{8}$ "

A WORD ABOUT BUTTONHOLE WIDTH

The width indicated for each operation in this section is an **approximate** setting. You may need to adjust width to suit your fabric... experiment!

DECORATIVE EMBROIDERY DESIGNS

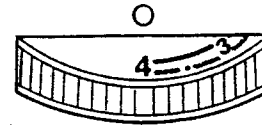
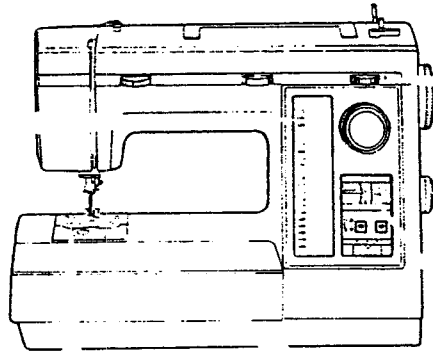
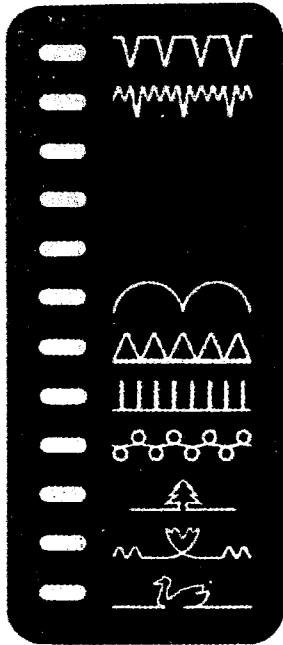

4 - 1

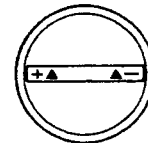

See next page.

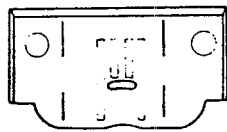

Zigzag needle plate

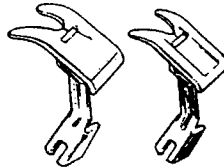

Zigzag or satin foot

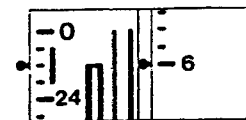

Green patterns Yellow patterns



Domino



Diamond

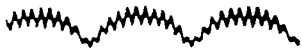

Crescent



Arabesque

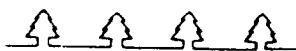

Tree



Tulip

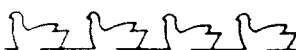

Swan

You may get the look and feel of hand embroidery infinitely faster and easier by your machine.

Just choose which of the designs you want to sew alone or in combination with each other.

TIPS ON DESIGN STITCHING

1. Always make a practice design on a scrap of the fabric you plan to use.
2. Start with a full bobbin and plenty of thread on the spool to avoid running out of thread in the middle of your design.
3. Reduce the top thread tension slightly.
4. On a very soft fabric you may want to use a tissue paper backing or organdy that can be cut away.

ADJUSTING STITCH BALANCE OF YELLOW PATTERNS

When sewing yellow patterns, you may need to make slight adjustment to the stitch modifier to produce perfect designs.

If the stitches are too far apart, turn the control slightly clockwise; if they are closer together, turn counter-clockwise.

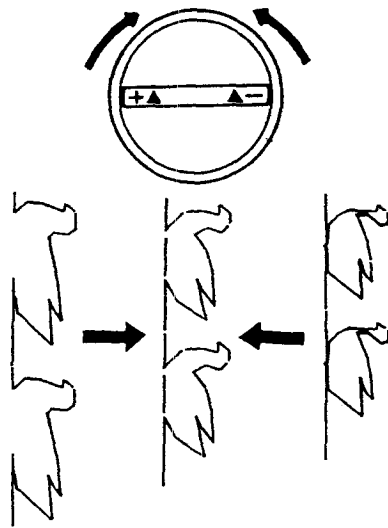

APPLICATIONS

Create the loveliest of custom designs - your own personal touch. There is much you can do by adjusting stitch width or length. Below

you see some applications and variations. You'll find many more design ideas as you become more expert.



Crescent pattern on collar



Diamond on narrow hem

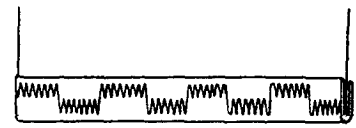

Domino on bias tape

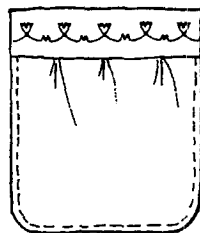

Tulip on pocket

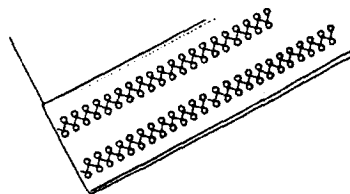

Arabesque on pillow case



Crescent and diamond in combination

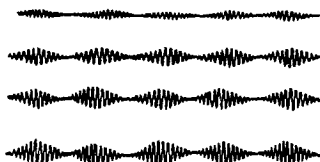

Variation of width of diamond pattern



Variation of both width and length of swan pattern

WARRANTY

FULL 30-YEAR WARRANTY ON SEWING MACHINE HEAD

For 30 years from the date of purchase, Sears will, free of charge, repair defects in material or workmanship which appear in the sewing machine head.

FULL TWO YEAR WARRANTY ON ELECTRICAL EQUIPMENT OF SEWING MACHINE

For two years from the date of purchase, Sears will, free of charge, repair defects in material or workmanship which appear in the electrical equipment of the sewing machine, including motor, wiring, switch and speed control.

FULL 90-DAY WARRANTY ON ALL PARTS AND MECHANICAL ADJUSTMENTS

For 90 days from the date of purchase, Sears will, free of charge, replace any parts and provide mechanical service necessary for proper operation of the sewing machine, except for normal maintenance.

To obtain warranty service described above, SIMPLY CONTACT THE NEAREST SEARS STORE OR SERVICE CENTER IN THE UNITED STATES. This warranty applies only while this product is in use in the United States.

This warranty gives you specific legal rights, and you may also have other rights which vary from state to state.

SEARS, ROEBUCK AND CO., Dept. 698/731A, Sears Tower, Chicago, IL 60684

SEWING MACHINE

Now that you have purchased your Kenmore Sewing Machine, should a need ever exist for repair parts or service, simply contact any Sears Service Center and most Sears, Roebuck and Co. Stores. Be sure to provide all pertinent facts when you call or visit.

The model number of your Sewing Machine will be shown on your nomenclature plate on the back of your Sewing Machine. See page 3 for location.

WHEN ORDERING REPAIR PARTS, ALWAYS GIVE THE FOLLOWING INFORMATION:

*MODEL NUMBER *NAME OF ITEM *PART DESCRIPTION

If the parts you need are not stocked locally, your order will be electronically transmitted to a Sears Repair Parts Distribution Center for handling.

SEARS, ROEBUCK AND CO., Chicago, IL 60684 U.S.A.