



website <http://www.lgservice.com>  
e-mail <http://www.lgservice.com/techsup.html>

# ROOM AIR CONDITIONER OWNER'S MANUAL

Please read the operating instructions and safety precautions carefully and thoroughly before installing and operating your room air conditioner.

# MANUEL D'UTILISATION CLIMATISEUR DE FENÊTRE

Veillez lire attentivement et en entier ce guide d'utilisation et les mesures de sécurité ci-incluses avant de procéder à l'installation et au fonctionnement de votre climatiseur.

**MODELS, MODÈLES:**

**LXA1010ACL      LXA1210ACL**

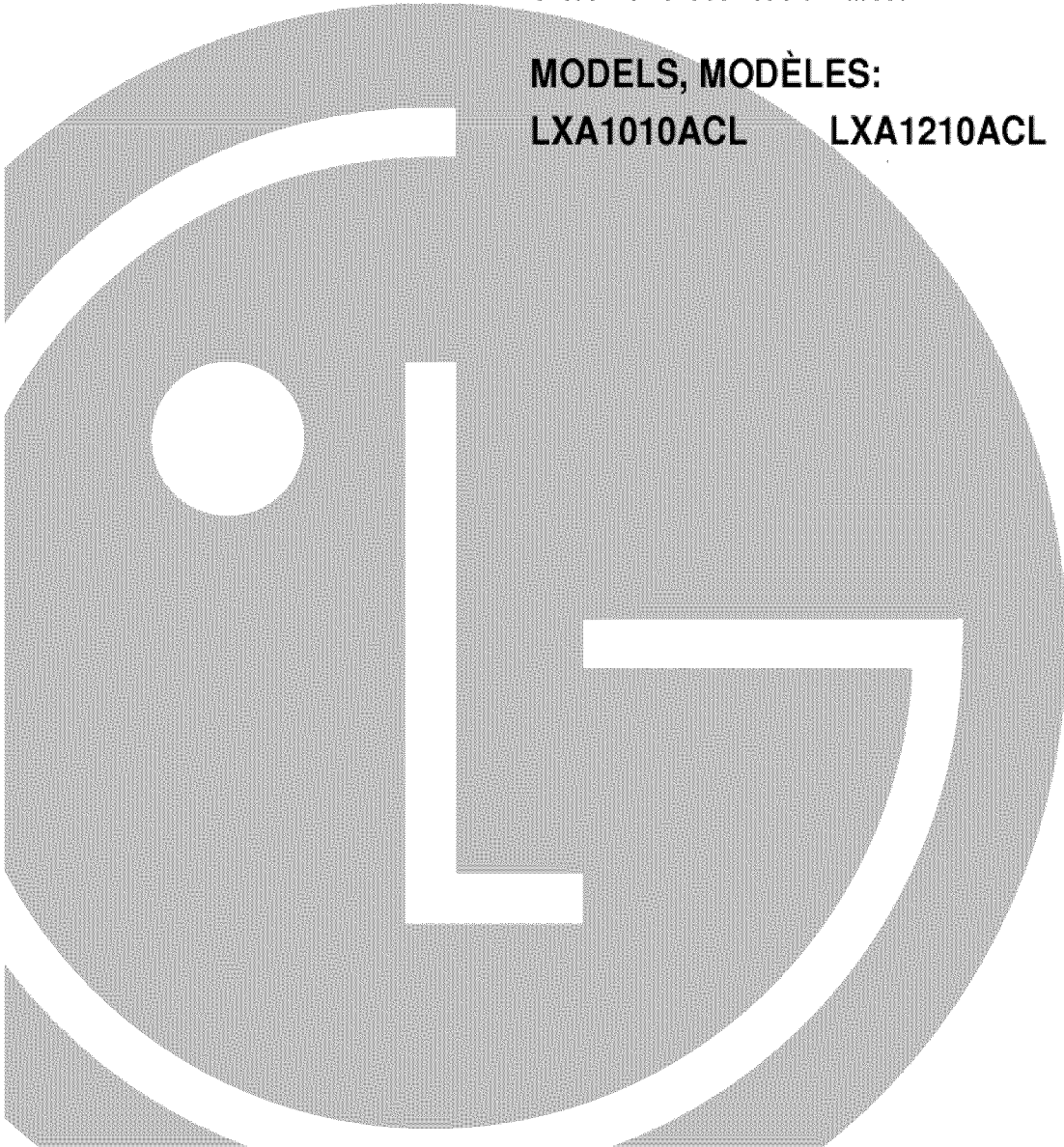

**Safety Precautions**

Safety Precautions .....3

**Electrical Data**

Electrical Data .....5

**About the Controls on the Air Conditioner**

Controls .....6  
 Ventilation .....8  
 Air Direction .....8

**Care and Maintenance**

Air Filter Cleaning .....9  
 How to Attach Front Grille to Cabinet .....9

**Features and Installation**

Features .....10  
 How to Install the Unit .....11  
 How to Replace the Unit ..11  
 Installation Kits Contents..12

**Before you call for service...**

Normal Operation .....15  
 Abnormal Operation .....15



**FOR YOUR RECORDS**

Staple your receipt to this page in case you need it later. Write down the model and serial numbers here:

**Model #**

**Serial #**

You can find them on a label on the side of each unit.

**Dealer's Name**

**Date Purchased**



**READ THIS MANUAL**

Inside you will find many helpful hints on how to use and maintain your air conditioner properly. Just a little preventive care on your part can save you a great deal of time and money over the life of your air conditioner.

You'll find many answers to common problems in the chart of troubleshooting tips. If you review our chart of **Troubleshooting Tips** first, you may not need to call for service at all.

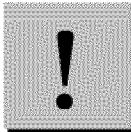

**CAUTION**



- Contact an authorized Service technician for repair or maintenance of this unit.
- The air conditioner is not intended for use by young children or invalids without supervision.
- Young children should be supervised to ensure that they do not play with the air conditioner.





# Safety Precautions

To prevent injury to the user or other people and property damage, the following instructions must be followed.

- Incorrect operation due to ignoring of instruction will cause harm or damage.  
The seriousness is classified by the following indications.

	<b>WARNING</b> : This symbol indicates the possibility of death or serious injury.
	<b>CAUTION</b> : This symbol indicates the possibility of injury or damage to properties only.

- Meanings of symbols used in this manual are as shown below.

	<b>Be sure not to do this.</b>
	<b>Be sure to follow the instruction.</b>

## ⚠ WARNING

**Plug in the power plug properly.**

- Otherwise, it will cause electric shock or fire due to heat generation.

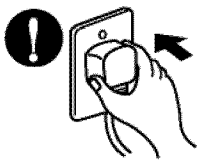

**Do not operate or stop the unit by inserting or pulling out the power plug.**

- It will cause electric shock or fire due to heat generation.



**Do not damage or use an unspecified power cord.**

- It will cause electric shock or fire.
- If the power cord is damaged, it must be replaced by the manufacturer or an authorized service center or a similarly qualified person in order to avoid a hazard.

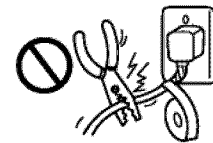

**Do not modify power cord length or share the outlet with other appliances.**

- It will cause electric shock or fire due to heat generation.

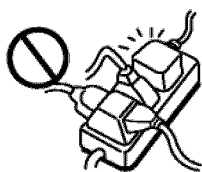

**Do not operate with wet hand or in damp environment.**

- It will cause electric shock.



**Do not direct airflow at room occupants only.**

- This could damage your health.

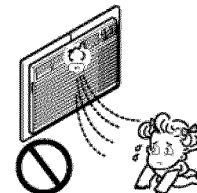

**CAUTION**

**When the air filter is to be removed, do not touch the metal parts of the unit.**

- They are sharp and may cause an injury.

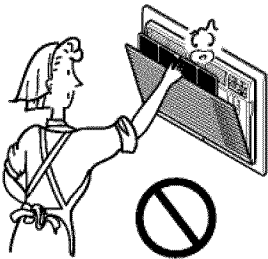

**Do not clean the air conditioner with water.**

- Water may enter the unit and degrade the insulation. It may cause an electric shock.

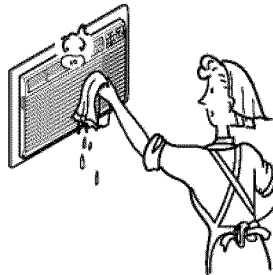

**When the unit is to be cleaned, switch off, and turn off the breaker.**

- Since the fan rotates at high speed during operation, it may cause an injury.

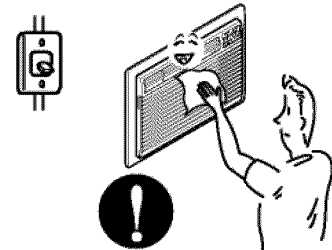

**Do not put a pet or house plant where it will be exposed to direct air flow.**

- This could injure the pets or plants.

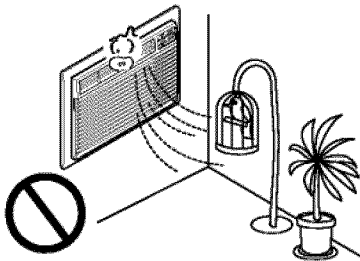

**Do not use for special purposes.**

- Do not use this air conditioner to preserve precision devices, food, pets, plants, and art objects. It may cause deterioration of quality, etc.

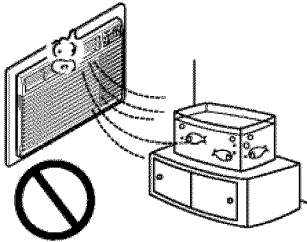

**Do not operate switches with wet hands.**

- It may cause an electric shock.

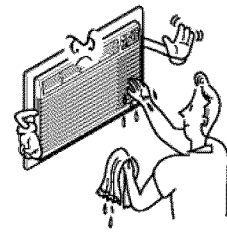

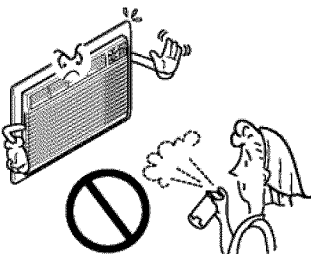

**Do not apply an insecticide or flammable spray.**

- It may cause a fire or deformation of the cabinet.



# Electrical Data

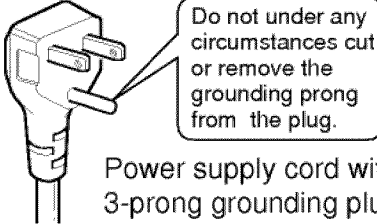



## Electrical Data (For 115V model)

Line Cord Plug	Use Wall Receptacle	Power Supply
 <p>Power supply cord with 3-prong grounding plug</p>	<p><b>Parallel type</b></p>  <p>Standard 125V, 3-wire grounding receptacle rated 15A, 125V AC</p>	<p>Use 15 AMP time delay fuse or 15 AMP circuit breaker.</p>

### USE OF EXTENSION CORDS

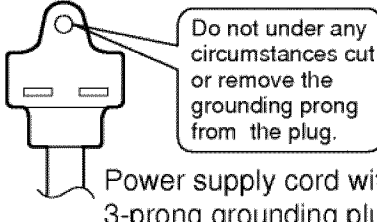
Because of potential safety hazards, we strongly discourage the use of an extension cord. However, if you wish to use an extension cord, use a CSA certified/UL-listed 3-wire (grounding) extension cord, rated 15A, 125V.

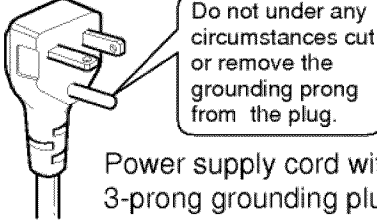
## Electrical Data (For 230/208V model)

Line Cord Plug	Use Wall Receptacle	Power Supply
 <p>Power supply cord with 3-prong grounding plug</p>	<p><b>Tandem type</b></p>  <p>Standard 250V, 3-wire grounding receptacle rated 15A, 250V AC</p>	<p>Use 15 AMP time delay fuse or circuit breaker.</p>
 <p>Power supply cord with 3-prong grounding plug</p>	<p><b>Perpendicular type</b></p>  <p>Standard 250V, 3-wire grounding receptacle rated 20A, 250V AC</p>	<p>Use 20 AMP time delay fuse or circuit breaker. Refer to the nameplate for correct fusing.</p>

All wiring should be made in accordance with local electrical codes and regulations.

**NOTE :** Aluminum house wiring may pose special problems. Consult a qualified electrician.

### ■ ELECTRICAL SAFETY

#### IMPORTANT GROUNDING INSTRUCTIONS

Air conditioner has a three-prong grounding plug on its power supply cord, which must be plugged into properly grounded three-prong wall receptacle for your protection against possible shock hazard.

**FUSE** – Use a time-delay fuse or circuit breaker. Refer to the nameplate for proper power supply requirements.

#### 208, 230, and 208/230 VOLT UNITS

These units are equipped with a three-prong grounding plug on the power supply cord, which must be plugged into a matching properly grounded three-prong wall receptacle for your protection against possible shock hazard. If such an outlet is not present, one must be installed by a qualified electrician in accordance with the National Electrical Code and local codes and ordinances.

**NOTE:** DO NOT USE AN EXTENSION CORD ON 208, 230, AND 208/230 VOLT UNITS.

# About the Controls on the Air Conditioner

The controls will look like one of the following:

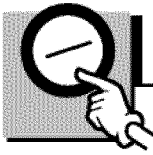

## Controls – Cooling Only

<p><b>Operation</b></p>	<p>Off - Turns air conditioner off.          Med Fan - Med speed fan operation without cooling.          Low Fan - Low speed fan operation without cooling.          High Cool - Cooling with high speed fan operation.          Med Cool - Cooling with med speed fan operation.          Low Cool - Cooling with low speed fan operation.</p>
<p><b>Thermostat</b></p>	<p>This automatically controls the temperature of the indoor air. Turn the knob so that arrow points to the larger marks for greater cooling. Point the arrow to the smaller marks for more moderate cooling. (i.e. the higher number, the greater cooling)</p>

About the Controls on the Air Conditioner

### • FOR NORMAL COOLING

1. Turn the Operation Knob to the **High Cool** from the **Low Cool** setting.
2. Set the Thermostat control to the desired temperature mark **5** (the mid-point is a good starting position). If the room temperature is not satisfactory after a reasonable time, adjust the control to a cooler or warmer setting, as appropriate.

### • FOR MAXIMUM COOLING

1. Turn the Operation Knob to the **High Cool** setting.
2. Set the Thermostat control to the largest **9** temperature mark.

### • FOR QUIETER OPERATION

1. Turn the Operation Knob to the **Low Cool** setting.
2. Set the Thermostat control as needed.

### • ENERGY SAVER (optional)

**On** : Both the fan and the compressor turn on and turn off together while operation knob is set to the Cool position.

You can get the more economical operation.

**Off** : The fan runs constantly while operation knob is set to the Cool position.

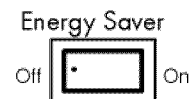

You can access the Energy Saver switch when you open the inlet grille.

The controls will look like one of the following:

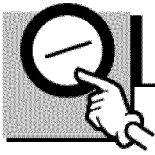

## Controls – Cooling & Heating

<p><b>Operation</b></p>	<p>Off ( ○ ): Turns the air conditioner off.</p> <p>Fan ( ⊕ ): The low fan speed operation without cooling (heating).</p> <p>Low Cool ( * ): Cooling with the low speed fan operation.</p> <p>High Cool ( ✱ ): Cooling with the high speed fan operation.</p> <p>Low Heat ( ☀ ): Heating with the low speed fan operation.</p> <p>High Heat ( ☀ ): Heating with the high speed fan operation.</p>
<p><b>Thermostat</b></p>	<p>Turn the thermostat control to the desired setting. The central position is a normal setting for average conditions. You can change this setting, if necessary, in accordance with your temperature preference.</p> <p>The thermostat automatically controls cooling or heating, but the fan runs continuously whenever the air conditioner is in operation. If the room is too warm, turn the thermostat control clockwise. If the room is too cool, turn the thermostat control counterclockwise.</p>

About the Controls on the Air Conditioner

### • THE AIR CONDITIONER

This automatically controls the temperature of the indoor air.

The compressor will turn on and off to keep the room at the setting temperature.

In the heating operation, the electric heater will turn on and off to keep the room at the setting temperature.

### • HEAT PUMP MODELS

When the outdoor temperature is lower than -4°C (24°F), the electric heater will turn on instead of the heat pump.

#### CAUTION

When the air conditioner has been performed its cooling or heating operation and is turned off or set to the fan position, wait at least 3 minutes before resetting to the cooling operation again.

A slight heat odor may come from the unit when first switching to HEAT after the cooling season is over. This odor, caused by fine dust particles on the heater, will disappear quickly. This is harmless.

---

*Additional controls and important information.*

## **Ventilation**

The ventilation lever is located in the right of the air discharge.  
The ventilation lever must be in the CLOSE position in order to maintain the best cooling conditions.  
When fresh air is necessary in the room, set the ventilation lever to the OPEN position.  
The damper is opened and room air is exhausted outside.

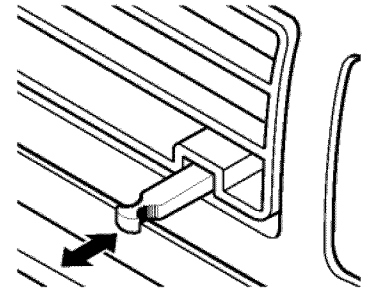

**PULL OPEN / PUSH CLOSE**

## **Air Direction**

The direction of air can be controlled wherever you want by adjusting the horizontal louver and the vertical louver.

### **• HORIZONTAL AIR-DIRECTION CONTROL**

The horizontal air direction is adjusted by moving vertical louver.  
The lever of vertical louver is located in the right and left side of the air discharge.

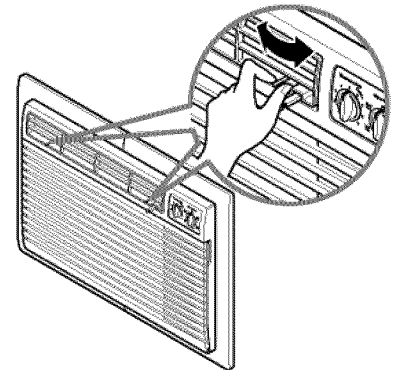

### **• VERTICAL AIR-DIRECTION CONTROL**

The vertical air direction is adjusted by moving the horizontal louver.

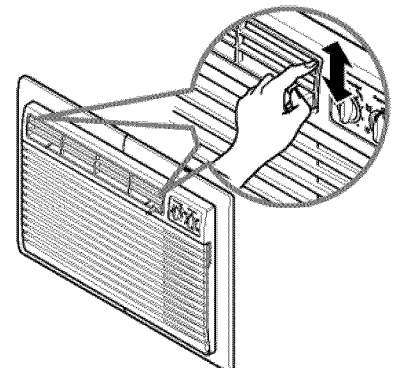



# Care and Maintenance

TURN THE AIR CONDITIONER OFF AND REMOVE THE PLUG FROM THE POWER OUTLET.

## Air Filter Cleaning

The air filter should be checked at least twice a month to see if cleaning is necessary. Trapped particles in the filter will build up and block the airflow. This reduces the cooling capacity and also causes an accumulation of frost on the cooling coils.

If the filter becomes torn or damaged you should replace immediately. Replacement filters are available from your salesperson, dealer, and the authorized customer service centers.

1. Open the inlet grille downward by pulling out the top of the inlet grille.
2. Remove the air filter from the front grille assembly by pulling the air filter up slightly.
3. Wash the filter using lukewarm water below 40°C (104°F).
4. Gently shake the excess water from the filter completely. Replace the filter.

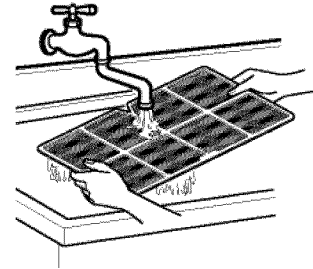
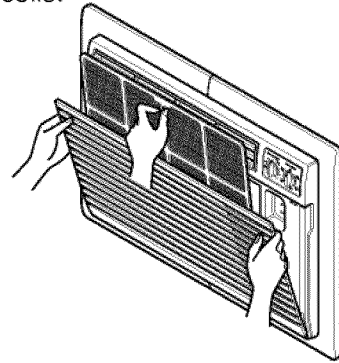

## How to Attach Front Grille to Cabinet

The front grille can be removed for cleaning or to check the model and serial numbers. For your safety, you should attach the front grille as the following procedures.

1. Pull down front grille from the cabinet top.
2. Push front grille's tips toward the cabinet in order to insert front grille's tabs into the cabinet.
3. Open the inlet grille.
4. Tighten the screw through the front grille into the plate of control box.
5. Close inlet grille.

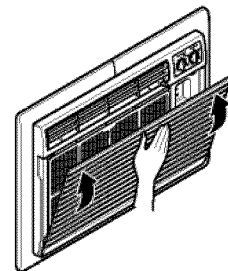
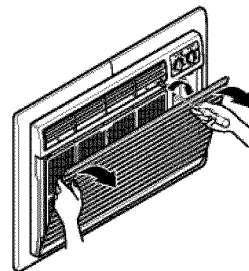
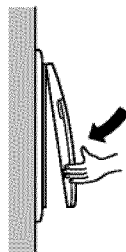
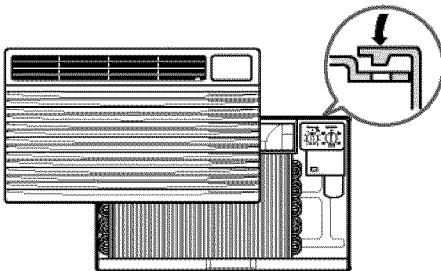

About the Controls on  
the Air Conditioner

# Features and Installation

Learning parts name prior to installation will help you understand the installation procedure.

## Features

### The Unit

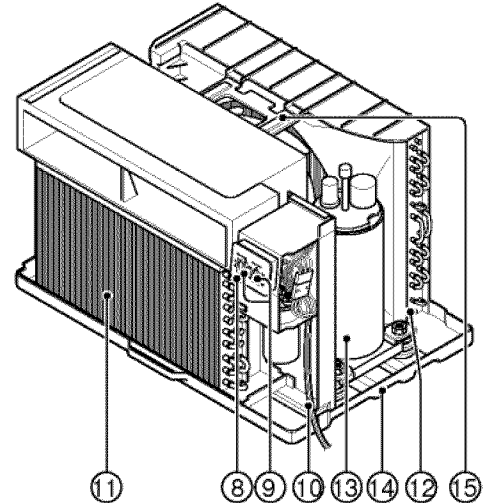
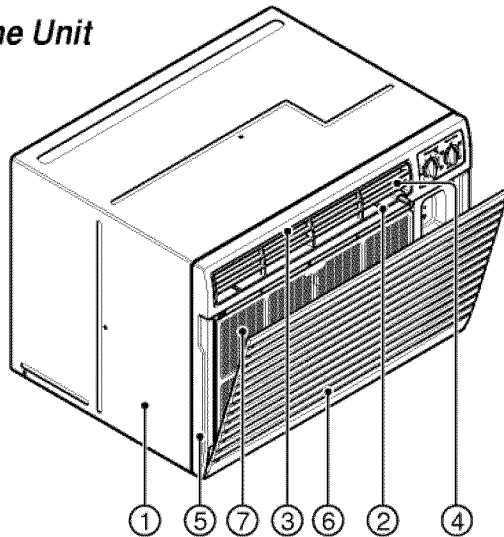

### The Sleeve and the Rear Grille (optional)

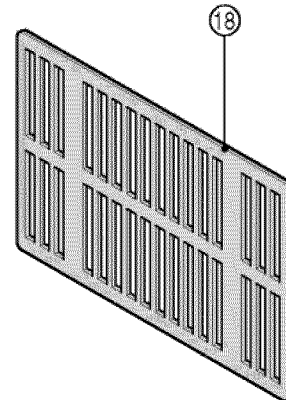
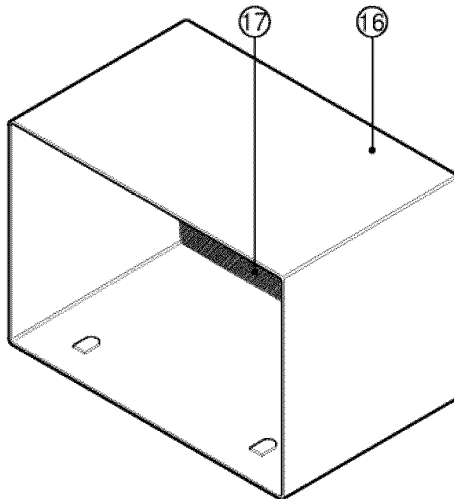

- |  |   |
|--|---|
| 1. CABINET                                       | 11. EVAPORATOR  |
| 2. HORIZONTAL AIR DEFLECTOR<br>(Vertical Louver) | 12. CONDENSER   |
| 3. VERTICAL AIR DEFLECTOR<br>(Horizontal Louver) | 13. COMPRESSOR  |
| 4. AIR DISCHARGE                                 | 14. BASE PAN  |
| 5. FRONT GRILLE                                  | 15. BRACE   |
| 6. INLET GRILLE (Air Intake)                     | 16. SLEEVE ASSEMBLY<br>(Including Expanded Aluminum Rear grille,<br>optional) |
| 7. AIR FILTER                                    | 17. REAR GRILLE<br>(Expanded Aluminum Rear grille, optional)                  |
| 8. CONTROL BOARD                                 | 18. REAR GRILLE<br>(Aluminum louvered Rear grille, optional)                  |
| 9. KNOBS   |   |
| 10. POWER CORD                                   |   |

## How to Install the Unit



**CAUTION** : There are sharp edges that can cause serious cuts.



**CAUTION** : When lifting the air conditioner, it is HEAVY. Use 2 people to lift.

For existing sleeve, you should measure the wall sleeve dimensions.

You can install the new air conditioner according to these installation instructions to achieve the best performance. All wall sleeves used to mount the new air conditioner must be in good structural condition and have the rear grille that securely attaches to the sleeve or the flange of the sleeve to secure the new air conditioner.

With the LG sleeve, you can maintain the best performance of the new air conditioner.

If you keep the existing sleeve, you run the risk of poor performance or product failure.

This is not covered under the LG warranty.

### Dimension of air conditioner

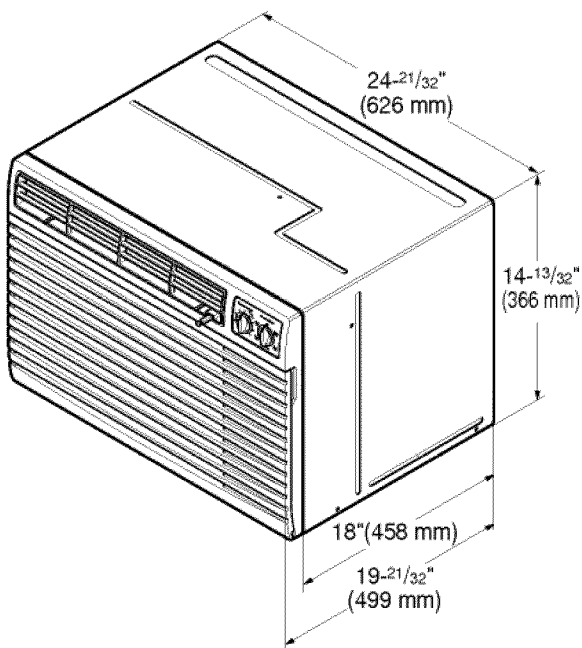

### Dimension of sleeve assembly (optional)

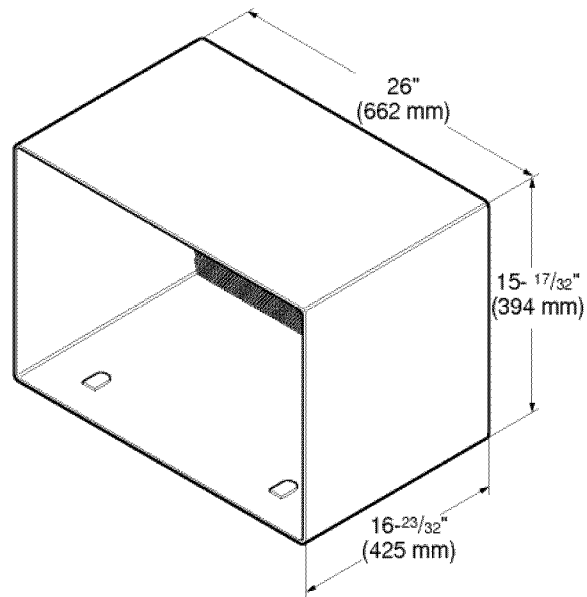

## How to Replace the Unit

**Note** : When you completed the installation, the new air conditioner unit should have a rearward slope, as shown below.

1. Remove the old air conditioner from the wall sleeve and prepare the wall sleeve.  
Clean the interior of the sleeve (do not disturb the insulation or seals).  
The wall sleeve must be fastened in the wall securely before installing the new air conditioner.

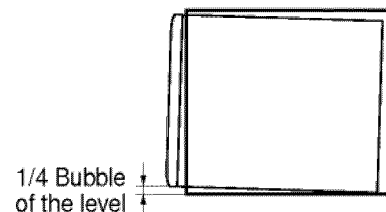

# Installation Kits Contents

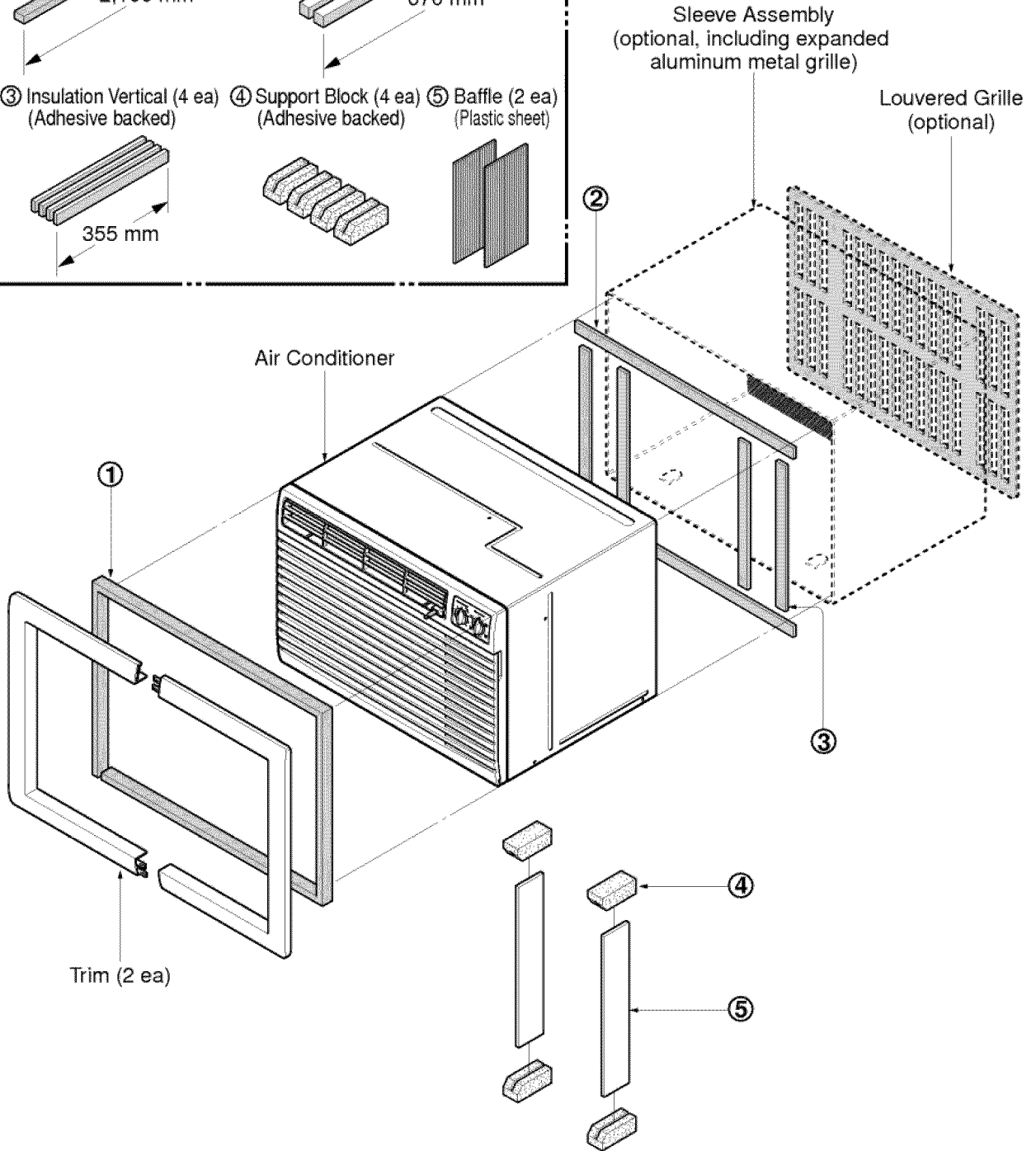
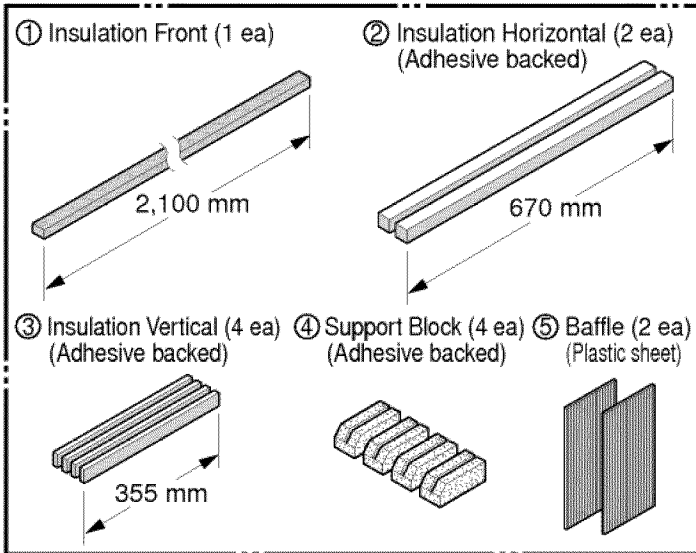

Features and Installation

- Prepare the wall sleeve for installation of the new unit according to the following installation procedures. Before you prepare the wall sleeve, you should check the wall sleeve dimensions.
- Redirect the louvers at the back of the wall sleeves as following **A** and **B** lengths in the below table.

Width of the existing wall sleeve	A	B
25-1/2" (648 mm)	2-3/4" (70 mm)	4-3/4" (120 mm)
25-3/4" (654 mm)	2-3/4" (70 mm)	5" (130 mm)
26" (660 mm)	3" (75 mm)	5" (130 mm)
26-3/4" (680 mm)	3-1/4" (80 mm)	5-1/2" (140 mm)
27" (686 mm)	3-1/2" (90 mm)	5-1/2" (140 mm)

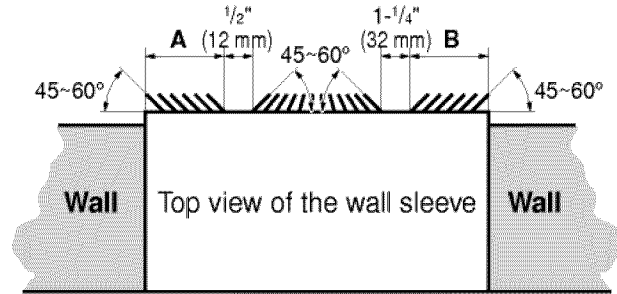

#### 4. Sleeve (up to 18 inches deep)

When the depth of your existing sleeve is deeper than 18", please skip to step 5. Remove the backing from horizontal insulation and attach them to the inside of the wall sleeve as shown below.

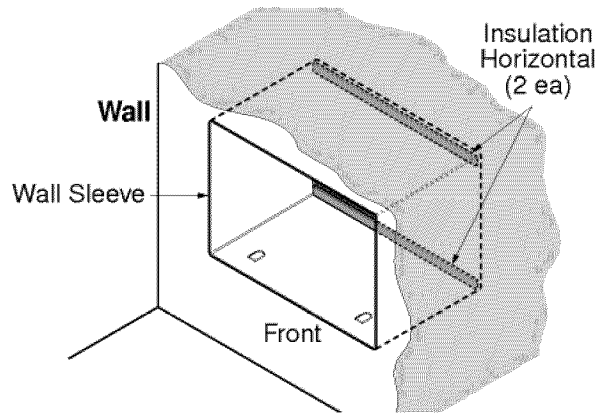

Remove the backing from insulation vertical and attach them to the inside of the wall sleeve, as shown below.

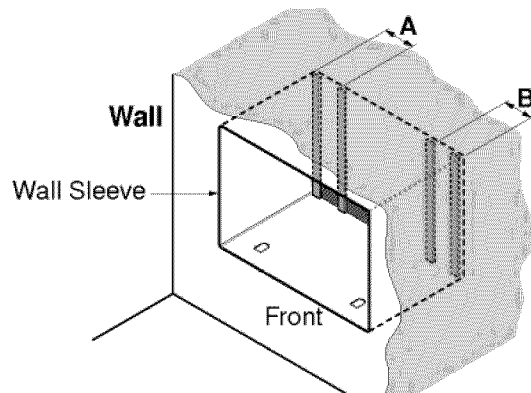

#### 5. Sleeve (18~22 inches deep)

When the depth of your existing sleeve is not deeper than 18", please skip to step 6. Cut the baffles and the support blocks as following **C** length in the below table.

Depth of the existing wall sleeve	C
18-5/8" (473 mm)	3/4" (20 mm)
19-3/4" (502 mm)	1-3/4" (45 mm)
22" (559 mm)	4" (100 mm)

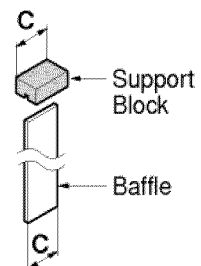

Remove the backing from vertical and horizontal insulation and attach them to the inside of the wall sleeve as shown below.

Remove the backing from the support blocks and attach them to the inside of the wall sleeve as shown below. Slide the baffles in the slots of the support blocks.

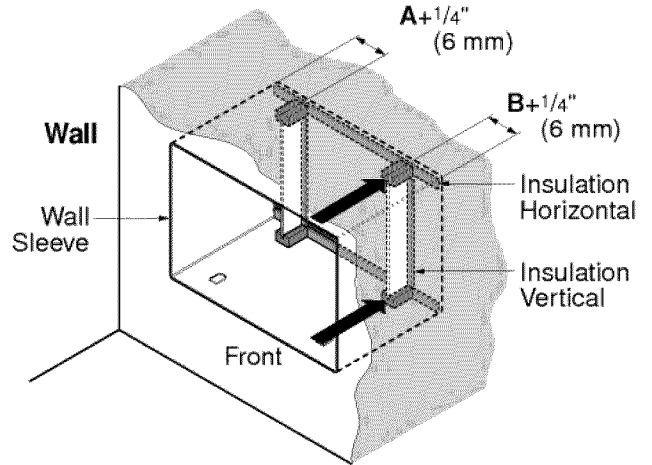

Remove the backing from vertical insulation and attach them to the back of the unit as shown below.

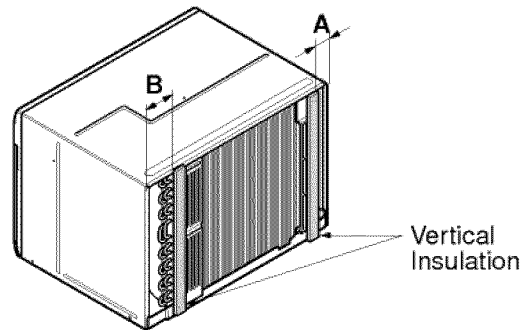

6. Install the new unit into the wall sleeve.
7. Insert front insulation between the wall sleeve and the unit. A flat-bladed screwdriver or putty knife is recommended.

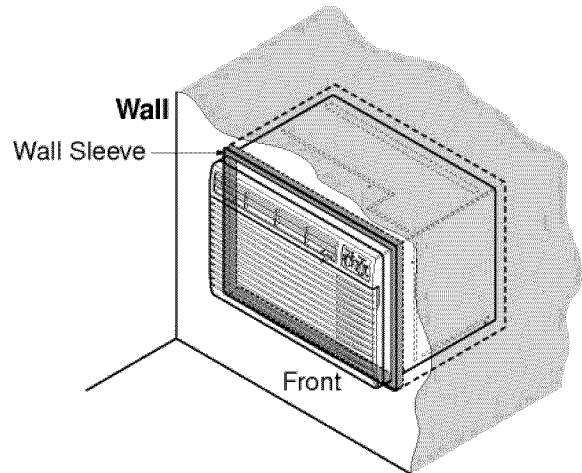

8. To assemble trim, insert the snaps into the slots of others. To install trim to the sleeve, slide the trim through the unit until it is flush with the wall sleeve.

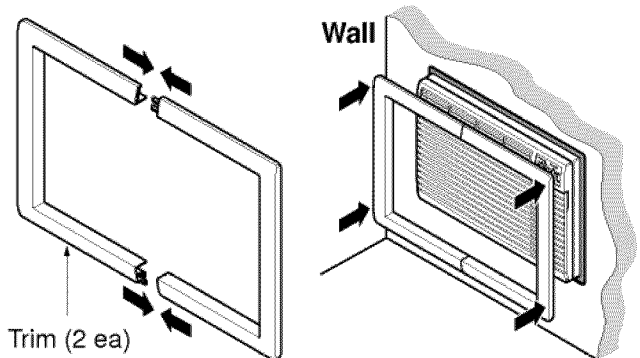

# Before you call for service...

*Troubleshooting Tips Save time and money!  
Review the chart below first and you may not need to call for service.*

## Normal Operation

- You may hear a pinging noise caused by water being picked up and thrown against the condenser on rainy days or when the humidity is high. This design feature helps remove moisture and improve efficiency.
- You may hear the thermostat click when the compressor cycles on and off.
- Water will collect in the base pan during high humidity or on rainy days. The water may overflow and drip from the outdoor side of the unit.
- The fan may run even when the compressor does not.

## Abnormal Operation

Problem	Possible Causes	What To Do
<b>Air conditioner does not start</b>	■ <i>The air conditioner is unplugged.</i>	• Make sure the air conditioner plug is pushed completely into the outlet.
	■ <i>The fuse is blown/circuit breaker is tripped.</i>	• Check the house fuse/circuit breaker box and replace the fuse or reset the breaker.
	■ <i>Power failure.</i>	• If power failure occurs, turn the mode control to <b>OFF</b> . When power is restored, wait 3 minutes to restart the air conditioner to prevent tripping of the compressor overload.
<b>Air conditioner does not cool as it should</b>	■ <i>Airflow is restricted.</i>	• Make sure there are no curtains, blinds, or furniture blocking the front of the air conditioner.
	■ <i>The THERMOSTAT may not be set high enough.</i>	• Turn the knob to a higher number. The highest setting provides maximum cooling.
	■ <i>The air filter is dirty.</i>	• Clean the filter at least every 2 weeks. See the operating instructions section.
	■ <i>The room may have been hot.</i>	• When the air conditioner is first turned on, you need to allow time for the room to cool down.
	■ <i>Cold air is escaping.</i>	• Check for open furnace floor registers and cold air returns. • Set the air conditioner's vent to the closed position.
<b>Air conditioner freezing up</b>	■ <i>Cooling coils have iced up.</i>	• See Air Conditioner Freezing Up below.
	■ <i>Ice blocks the air flow and stops the air conditioner from cooling the room.</i>	• Set the mode control at <b>Med Fan</b> or <b>High Cool</b> with the thermostat at <b>1</b> or <b>2</b> .