



Zoneline Series
Heat Pump Model 3200
Heat/Cool Model 2200

Zoneline[®]

Owner's Manual

	Important Safety Information	3
---	-------------------------------------	----------

	Operating Instructions <i>The Controls on Your Zoneline</i> <i>Care of Product</i>	4
---	---	----------

	Installation Instructions <i>Important Electrical Safety</i> <i>Adjustments and Auxiliary Controls</i>	10
--	---	-----------

	Helpful Information <i>Things That Are Normal</i>	19
---	---	-----------

	If Something Goes Wrong <i>Before You Call For Service</i> <i>GE Service Numbers</i> <i>Warranty</i>	20
---	--	-----------

GE Answer Center[®]
800.626.2000

GE Appliances

Welcome

Welcome to the GE family. We're proud of our quality products and we believe in dependable service. You'll see it in this easy-to-use manual and you'll hear it in the friendly voices of our customer service department.

Best of all, you'll experience these values each time you enjoy the comfort of your Zoneline. That's important, because your new Zoneline will be part of your family for a long time.

Start Here!

*Before using
your
Zoneline*

Staple your receipt to the inside back cover of this manual. You will need it to obtain service under warranty.

Write down the model and serial numbers here. They are on a label behind the room cabinet on the base pan.

Model number

Serial number

Date of purchase

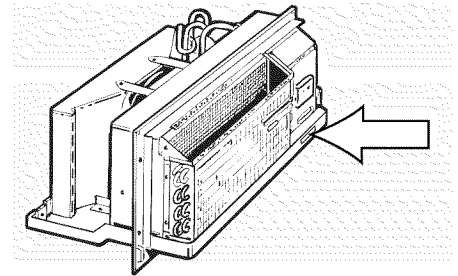

Need Help?

*Help us
help you*

800.626.2000

Before you call for service, there are a few things you can do to help us serve you better.

Read this manual. It contains instructions to help you use and maintain your Zoneline properly.

Save time and money. Check the section titled ***If Something Goes Wrong*** before calling. This section was designed to solve common problems that might occur.

If you do need service, you can relax knowing help is only a phone call away. Toll-free customer service numbers are included in the back of this manual. Or call the GE Answer Center[®] at 800.626.2000, 24 hours a day, 7 days a week.

IMPORTANT SAFETY INFORMATION



READ ALL SAFETY INFORMATION BEFORE USING

- This Zoneline must be properly installed in accordance with the Installation Instructions before it is used. See pages 10-12.
 - Repair or replace immediately all electric service cords that have become frayed or otherwise damaged.
 - Unplug or disconnect the Zoneline at the fuse box or circuit breaker before making any repairs.
- NOTE:** We strongly recommend that any servicing be performed by a qualified individual.

SAVE THESE INSTRUCTIONS

Replacing an existing unit?

For details see the **Installation Instructions** in the back of this manual.

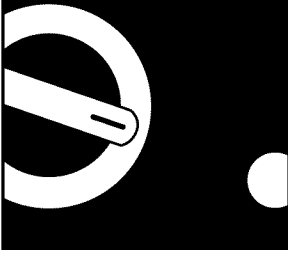

The
controls
on your
Zoneline

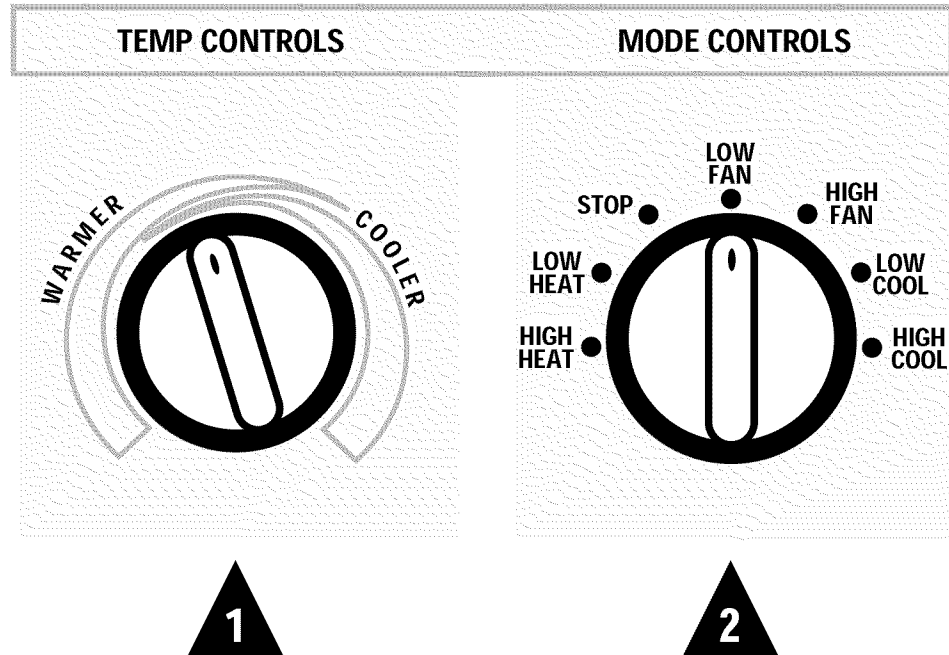

1 Temp Control

The temp control is used to maintain the room temperature. The compressor will cycle on and off to keep the room at the same level of comfort. When you turn the knob to **COOLER** (blue) the indoor air will become cooler. Turn the knob to **WARMER** (red) and the indoor air will become warmer.

3200 Series only

When the outdoor temperature is lower than 25°F., heat is provided by the electric heater in the air conditioner instead of by the heat pump.

2 Mode Control

HIGH COOL and **LOW COOL** provide cooling with different fan speeds.

HIGH HEAT and **LOW HEAT** provide heating with different fan speeds.

LOW FAN or **HIGH FAN** provides air circulation and filtering without cooling or heating.

NOTE:

If you move the switch from a cool or heat setting to STOP or to a fan setting, the unit has an automatic 3-minute delay before allowing the compressor to restart in the cool or heat mode.

Energy Tip



Keep the vent control at **CLOSE**. The room air will be filtered and circulated.

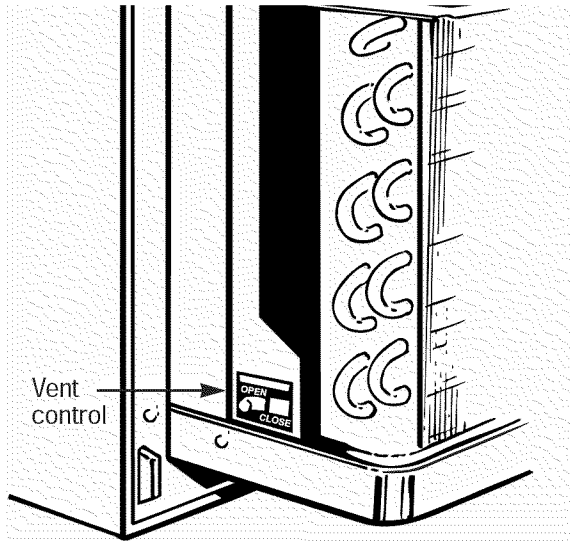

3

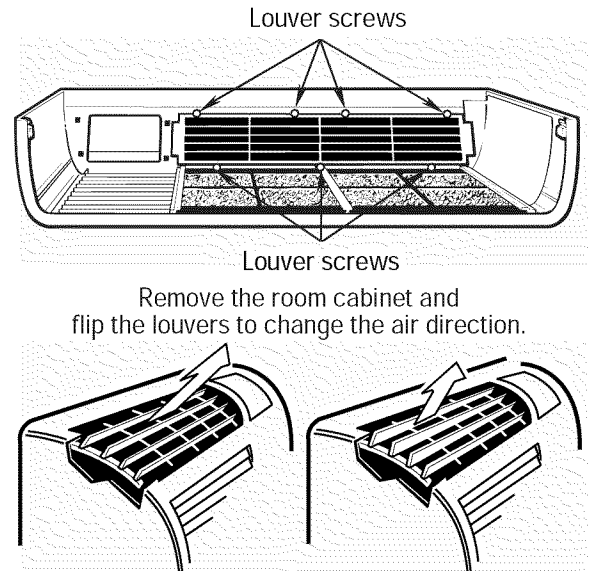

4

3 Ventilation Control

The ventilation control lever is located at the lower left side of the Zoneline unit, behind the room cabinet.

When set at **CLOSE**, only the air inside the room is circulated and filtered.

When set at **OPEN**, some outdoor air will be drawn into the room. This will reduce the heating or cooling efficiency.

4 Air Direction

To adjust the air direction, remove the room cabinet. Remove the 7 louver screws that hold the louvers in place. Flip the louver section 180°, replace the screws and the room cabinet.



Operating Instructions

Other Zoneline features

About Your Heat Pump 3200 Series only

Heat pumps can save money by removing heat from the outside air—even when the outside temperature is below freezing—and releasing that heat indoors.

To get the best performance from your heat pump, don't change the room thermostat very often.

Raising the heat setting 2–3 degrees will cause the Zoneline to use its electric heating elements in order to reach the new temperature setting quickly.

There is a three minute minimum compressor run time at any setting to prevent short cycling.

The indoor fan motor starts before the compressor and stops after the compressor cycles off.

The electric heating elements use much more electricity than heat pumps and cost more to operate.

To Remove the Room Cabinet

Additional controls are located behind the room cabinet.

To remove: Pull out at the bottom to release it from the tabs. Then lift up.

To replace: Place the tabs over the top rail. Push inward at the bottom until it snaps into place.

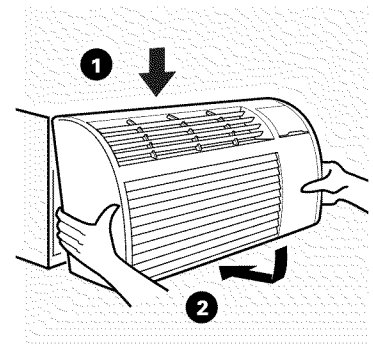
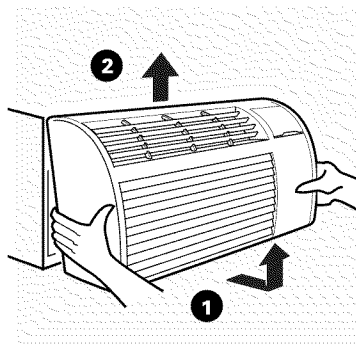



Auxiliary Controls

The auxiliary controls are located behind the room cabinet on the front of the unit control box. The factory settings will be in the **DOWN** position. The owner is responsible for checking switches and ensuring they are in the desired position.

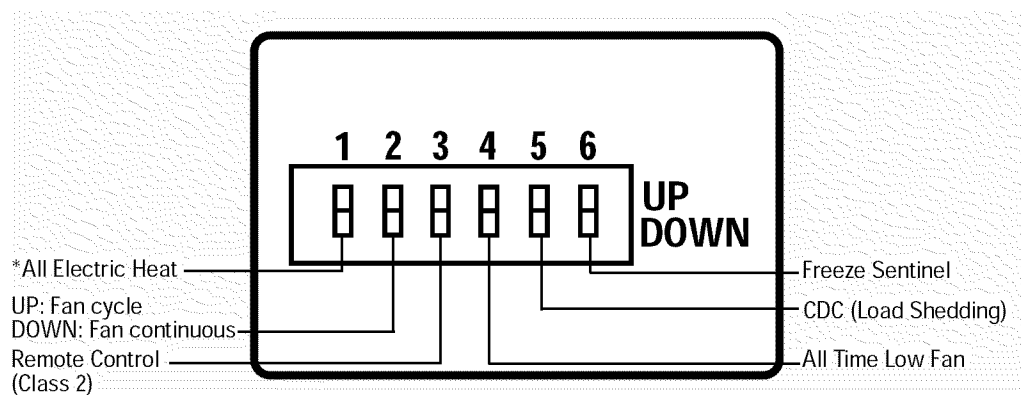

*Not on Model 2200 Series

Fan Switch

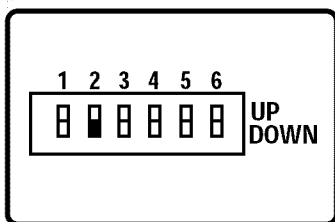

Auxiliary Controls

Down—Continuous Fan
Up—Cycle Fan

The fan switch #2 is located behind the room cabinet.

This switch is set at continuous fan (**DOWN**) at the factory to provide continuous fan operation in cool or heat modes. Leaving the switch in the continuous fan setting allows continuous circulation of room air and will result in a more balanced temperature throughout the room.

If you want the fan to cycle on and off with the compressor or with the heater, move the switch to cycle fan (**UP**).

Freeze Sentinel™

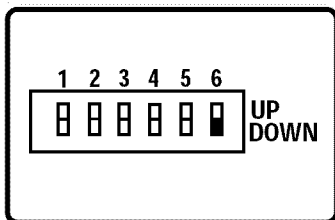

Switch #6 controls the Freeze Sentinel. When the switch is **DOWN**, the Freeze Sentinel automatically turns on the resistance heater and fan if the room temperature (sensed at the unit) drops to approximately 40° F. It will turn the heater off when the temperature reaches about 45° F.

The unit leaves the factory with the Freeze Sentinel in the **DOWN** (on) position.

The Freeze Sentinel helps prevent plumbing damage in the room due to sub-freezing temperatures.

If the Freeze Sentinel is set, it is active as long as power to the unit is on.

NOTE: The owner is responsible for checking the Freeze Sentinel switch and ensuring it is in the desired setting.



Operating Instructions

Care & Cleaning

Room Cabinet and Case

Turn the Zoneline off and disconnect the power supply.

To clean, use water and a mild detergent. Do not use bleach or abrasives. Some commercial cleaners may damage the plastic parts.

Outdoor Coils

The coils on the outdoor side of the Zoneline should be checked regularly. If they are clogged with dirt or soot they may be professionally steam cleaned, a service available through your GE service outlet. You will need to remove the chassis to inspect the coils because the dirt build-up occurs on the inside.

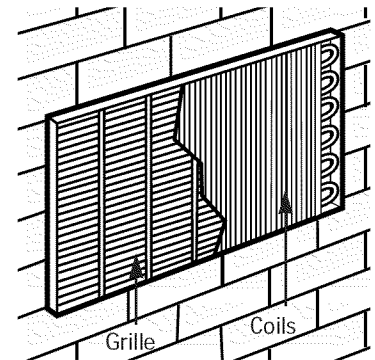

Clean the outside coils regularly.

Base Pan

In some installations, dirt or other debris may be blown into the unit from the outside and settle in the base pan (the bottom of the unit).

In some areas of the United States a “jell-like” substance may be seen in the base pan.

Check it periodically and clean it out, if necessary.



Air Filters

Operating Tip:
To maintain optimum performance, clean the filters at least every 30 days.

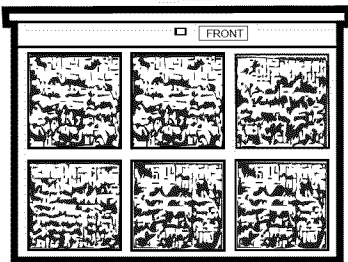

Dirty filter—Needs cleaning

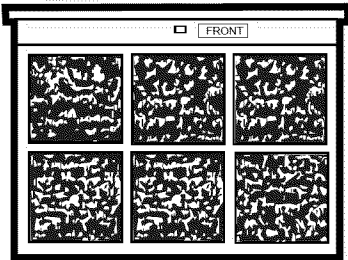

Clogged filter—Greatly reduces cooling, heating and airflow.

Turn the Zoneline off before cleaning.

The most important thing you can do to maintain the Zoneline is to clean the filter at least every 30 days. Clogged filters reduce cooling, heating and air flow.

Keeping these filters clean will:

- Decrease cost of operation.
- Save energy.
- Prevent clogged heat exchanger coils.
- Reduce the risk of premature component failure.

To clean the air filters:

- Vacuum off the heavy soil.
- Run water through the filters.
- Dry thoroughly before replacing.

To remove the air filters:

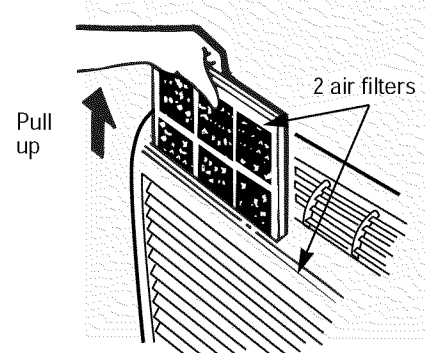

To replace the air filters:

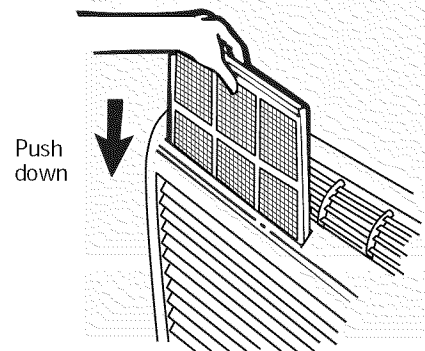

⚠ CAUTION:

DO NOT operate the Zoneline without the filters in place. If a filter becomes torn or damaged it should be replaced immediately.

Operating without the filters in place or with damaged filters will allow dirt and dust to reach the indoor coil and reduce the cooling, heating, airflow and efficiency of the unit.

Replacement filters are available from your salesperson, GE dealer, GE Service and Parts Center or authorized Customer Care[®] servicers.



Installation Instructions

Read carefully

If you have any questions, call the GE Answer Center at 800.626.2000.

Replacing an Existing Unit?

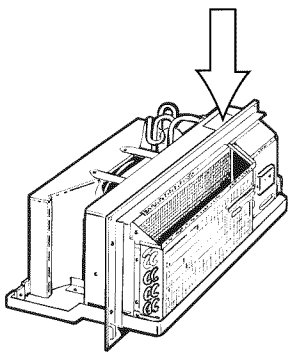

Check the "Essential Elements" label for important information.

- **Use the correct wall case.**

This chassis is designed to be installed in a GE plastic or insulated metal wall case. This minimizes condensation from forming on the room side of the case. If the current wall case is not insulated, you can reduce the possibility of condensation forming by installing insulation kit RAK901L, available where you purchased the chassis.

- **Use the correct outdoor grille.**

You should use the outdoor grilles shown on the "Essential Elements" label on the top of the chassis.

- If an existing grille is not replaced, capacity and efficiency will be reduced and the unit may fail to operate properly or fail prematurely. A deflector kit, RAK40, may be used with grilles that were not designed for your new GE Zonelines. The RAK40 contains air deflectors and gaskets that mount to the chassis to direct the hot exhaust air away from the air intake to allow the unit to function properly. The grille must have a 65% minimum free area.

- Any vertical deflectors in the existing rear grille should be removed to decrease condenser air recirculation which can cause the unit to "short-cycle" and lead to premature component failure.

- **Replacing a ducted chassis.**

New ducted installation—If this unit is to be installed in a new ducted application using a duct adaptor kit, the kit must be installed before the chassis is placed in the wall case. The installation instructions are packed with the kit.

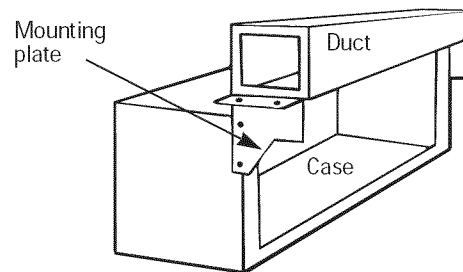

Existing ducted installation—Replacement of an existing ducted unit may require different components. Request this information from your sales representative.

- **Replacing 230/208 volt units.**

See page 12.

- **Replacing 265 volt units.**

See page 13.



Important Electrical Safety—Read Carefully

Installer: Leave these instructions with the Zonline.

Owner: Keep these instructions for future use.

Important Notes

- Follow the National Electrical Code (NEC) or local codes and ordinances.
- For personal safety, this Zonline must be properly grounded.
- Protective devices (fuses or circuit breakers) acceptable for Zonline installations are specified on the nameplate of each unit.

⚠ CAUTION:

- **Do not use an extension cord with this unit.**
- **Aluminum building wiring may present special problems—consult a qualified electrician.**
- **When the unit is in the STOP position there is still voltage to the electrical controls.**
- **Disconnect the power to the unit before servicing by:**
 - 1 **Removing the power cord (if it has one) from the wall receptacle.**
 - or—
 - 2 **Removing the branch circuit fuses or turning the circuit breakers off at the panel.**

Zonline Components

YOU WILL NEED: • *Phillips screwdriver*

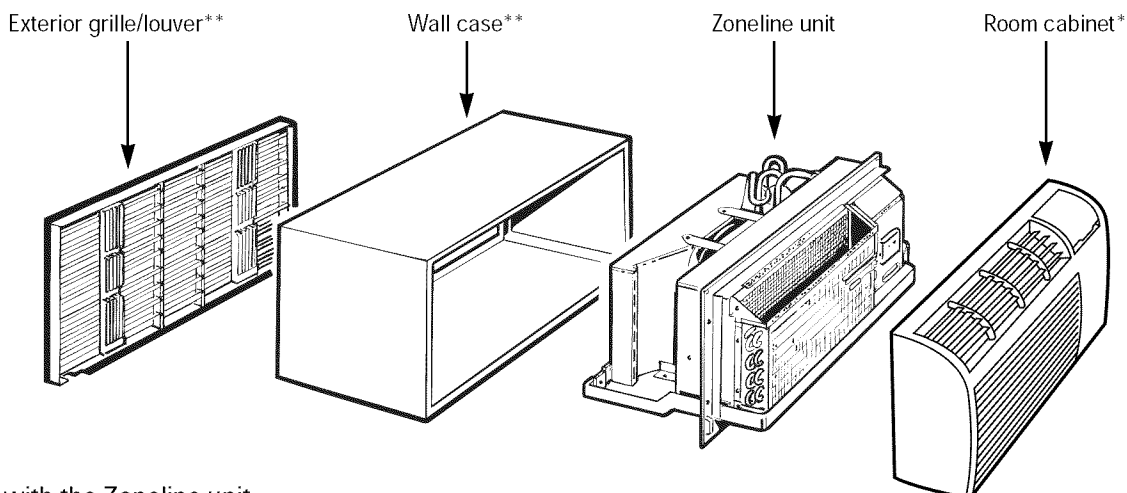

*Shipped with the Zonline unit

**Check the "Essential Elements" list on the unit



Installation Instructions

How to Connect

- 1 Remove the room cabinet.
- 2 Connect to electrical power.
- 3 See the special instructions below for applicable supply voltages.
- 4 Reinstall the room cabinet.

230/208 Volt Electrical Supply

All wiring, including installation of the receptacle, must be in accordance with the NEC and local codes, ordinances and regulations.

This unit is equipped with a line cord for appropriate amperage wall receptacle. See below.



Tandem
15 Amp.



Perpendicular
20 Amp.



Large Tandem
30 Amp.

Electrical wiring wall outlets 230/208 volts.



265 Volt Electrical Supply

⚠ WARNING

Connection of this 265V product to a branch circuit **MUST** be done by direct connection to be in compliance with the National Electric Code. Plugging of this unit directly into a building mounted exposed receptacle is not permitted by code.

These models must be installed using one of the following methods:

A Electrical subbase kits are available to provide a flexible enclosure for direct connection.

Branch Circuit and Chassis Amperage Rating	Proper GE Subbase Kit
15	RAK204E15
20	RAK204E20
30	RAK204E30

The instructions provided with the selected subbase kit must be carefully followed. It is the responsibility of the installer to ensure that connection of components is done in accordance with these instructions and all electrical codes.

B For direct connection to branch circuit wiring inside the provided junction box without using a subbase kit, the cord is to be cut and the wire ends stripped and connected as follows.

Steps for preparing cordset for direct connection:

- 1 Remove the junction box cover by taking out the front four screws.
- 2 Remove the junction box by taking out the top rear screw. Note how the tab at the lower right corner of the junction box serves to hold the corner in place. This will help when the box is being reinstalled. The cord will be coiled up inside the junction box.

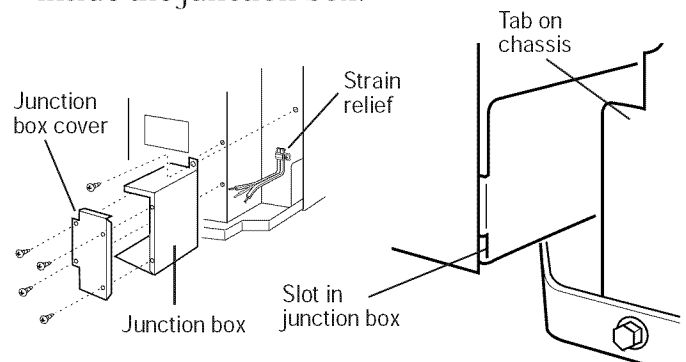

- 3 Measure 6" down the cord from the strain relief securing the cord to the chassis and cut the cord through at this point.
- 4 Carefully split the cord insulation at the center for 2" so as to separate into three insulated wires. Be careful not to cut through the center green ground wire insulation.
- 5 Strip 3/4" of the insulation away at the end of each of the three wires (L1, Neutral and Ground). The Neutral wire is identified by molded rib along its entire length. The L1 (Hot) wire insulation is smooth.

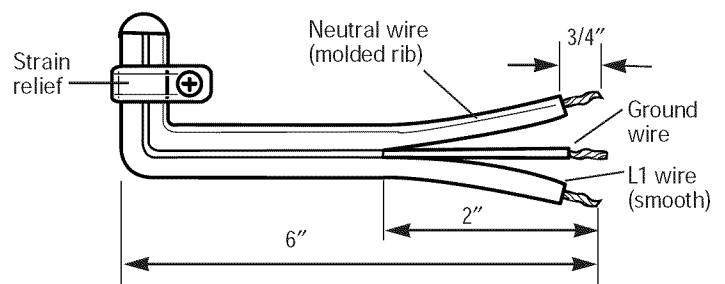



Installation Instructions

- 6** Use the round knockout at the bottom of the junction box to attach conduit coming from the branch circuit. Remove the knockout, attach the conduit and bring wires into the junction box. Leave 6" of wire free at the end of the conduit to allow connections to be made.

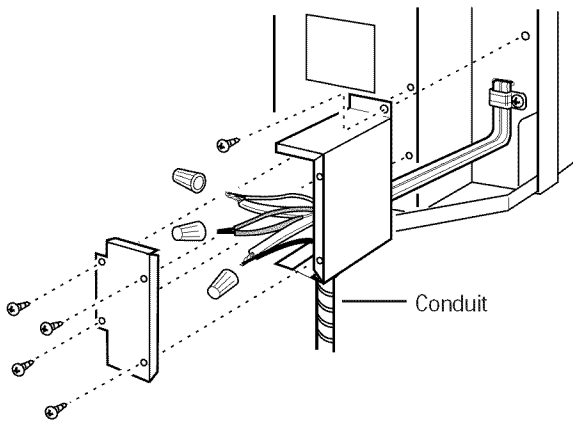

- 7** If a fuse and fuseholder are to be used, the knockout at the top of the box is for mounting a Buss Fuseholder. Be sure the fuse and fuseholder are of the same rating as the branch circuit. Leadwires at the fuse can be either soldered in place or attached using UL-listed 1/4" female (receptacle) crimp connectors.

- 8** Reinstall the junction box by engaging the tab at the lower rear, aligning the screw hole at the top and driving the one screw until secure. Be sure that all wire leads are inside the box and not pinched between the box and the chassis. The identified (ribbed) Neutral wire of the cordset **MUST** be connected to the white Neutral wire of the branch circuit. The green insulated ground wire from the chassis **MUST** be connected to the branch circuit ground wire.
- 9** Make all wire connections by using appropriate UL-listed electrical connectors and techniques (black to black, white to white and green to green).
- 10** Carefully tuck all wires and connections back inside the junction box. Be sure there are no loose connections or stray uninsulated wires exposed.
- 11** Place the junction box cover in place. Replace the four screws removed earlier and tighten securely.
- 12** Discard the unused portion of the plug and the cordset.



1 Install the Wall Case and the Exterior Grille

- 1 The RAB71 or RAB77 wall case must be properly installed per instructions packed with the case.
- 2 Remove the corrugated stiffener and the outdoor protective panel. Use the slit in the outdoor panel as a handhold and push out.

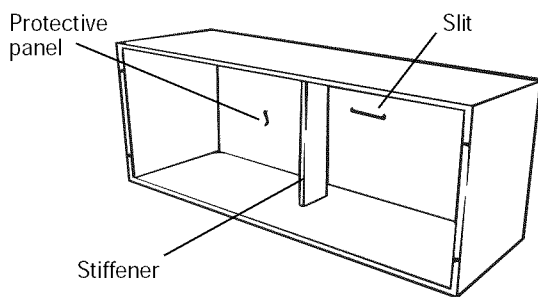

- 3 Install the exterior grille from the room side following instructions packed with the grille.

Insulated Wall Case

This chassis is designed to be installed in a GE plastic or an insulated steel wall case. This minimizes condensation from forming on the room side of the case.

The RAB71 wall case is insulated. Insulation kit RAK901L is available for use with RAB77 or existing uninsulated wall cases when needed.

NOTE: For installation with a subbase or duct adapter, see the instructions packed with those kits.

2 Remove the Shipping Tape from the Room Cabinet

- 1 Carefully remove shipping tape, if there is any, from the room cabinet and vent door.

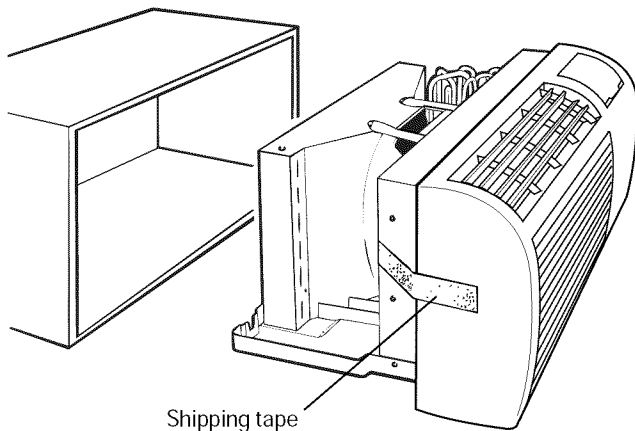

- 2 Remove the room cabinet by pulling it out at the bottom to release it, then lift it up to clear the rail along the unit top.

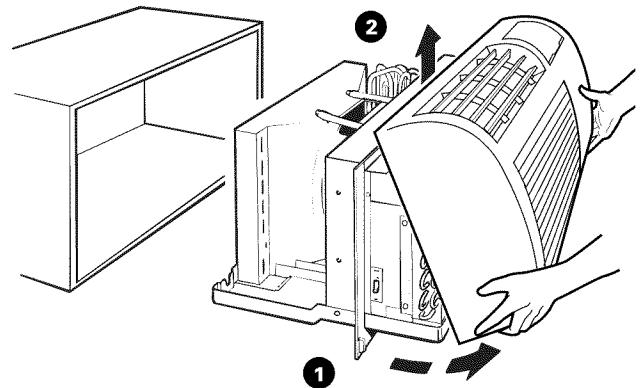



Installation Instructions

3 Install the Unit into the Wall Case

Slide the unit into the wall case and secure with four screws through the unit flange holes.

If an insulated wall case is needed, see **Install the Wall Case and Exterior Grille** section on the previous page.

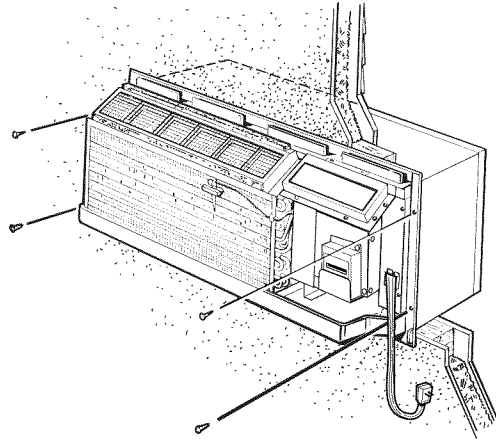

4 Replace the Room Cabinet

Reinstall the room cabinet by hooking the top over the rail along the unit top, then pushing it in at the bottom.

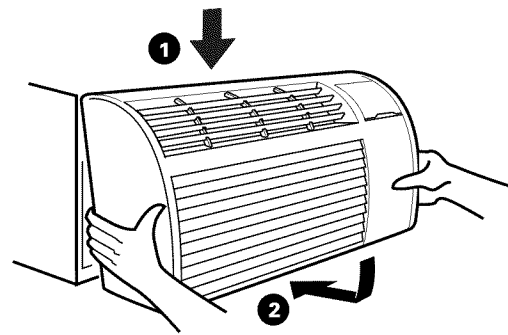



Low Voltage Connectors & Auxiliary Controls

NOTE: The owner is responsible for checking all switches and ensuring they are set in the desired setting.

Electric Heat Option—Model 3200 Series only

The Electric Heat Option switch #1 increases the Zoneline air temperature by using electric heat only. The heat pump is not used to produce any heat.

Using the Electric Heat Option is much more expensive than heating with the heat pump only.

To set the Electric Heat Option, move switch to the **ON** (up) position.

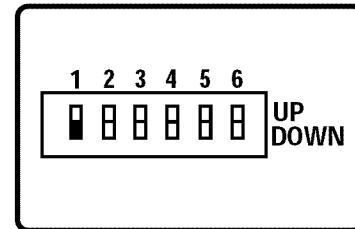

Auxiliary controls

Temperature Limiting

Temperature limiting can reduce energy costs by limiting the lowest temperature that can be set for cooling and the highest temperature that can be set for heating.

Limiting the maximum and minimum settings prevents users from turning the control to the extreme heat or cool positions.

The normal full range of the temp control is approximately 62° F to 85° F. The control range may be narrowed by the use of the temperature limiting screws located behind the control panel.

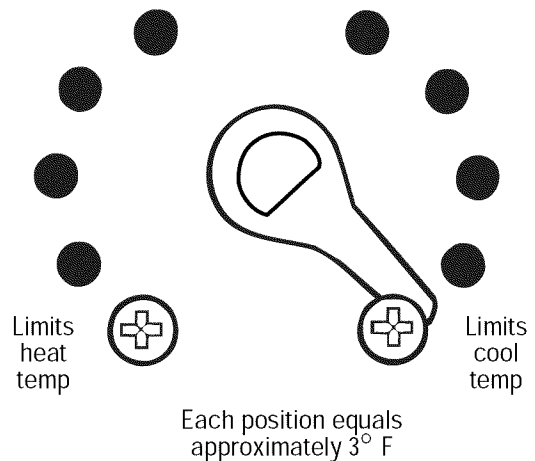



Installation Instructions

Remote Control/Wall Thermostat (Class 2)

To operate the Remote Control/Wall Thermostat (Class 2) switch #3, you must use an Optional Interface Module kit. See the Installation Instructions with accessory kit RAK0IM.

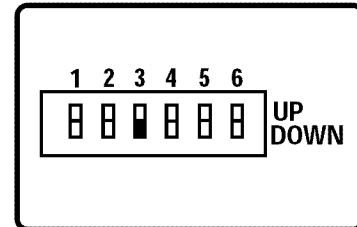

Auxiliary Controls

Central Desk Control (Load Shedding)

To operate Central Desk Control (CDC), switch #5, you must have an Optional Interface Module kit. See the Installation Instructions with accessory kit RAK0IM.

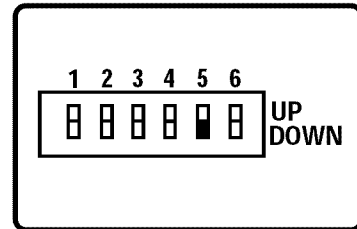

All-Time Low Fan



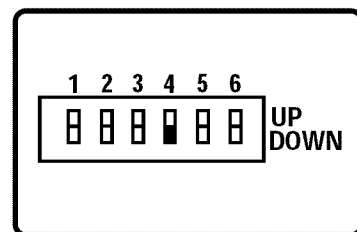

Switch #4 controls the All-Time Low Fan and is only effective with a Remote Control Thermostat. This function causes the indoor fan to operate at low speed. If the switch is **DOWN** (off) the fan will run in high speed. If the switch is **UP** (on) the fan will run in low speed.



Helpful Information

Things That Are Normal

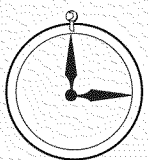

Noise	Explanation
PING!  POP! 	You may hear a pinging or popping noise caused by water being picked up and thrown against the condenser on rainy days or when the humidity is high. This design feature helps remove moisture and improve efficiency.
“CLICK”	You may hear relays click when the controls cycle on and off or are adjusted to change the room temperature.
DRIP 	Water will collect in the base pan during high humidity or on rainy days. The water may overflow and drip from the outdoor side of the unit.
WHIR! 	The indoor fan runs continuously when the unit is operating in the cooling mode, unless the fan switch behind the room cabinet is set at fan cycle (up). This will cause the fan to cycle on and off with the compressor. You may also hear a fan noise stop and start.
3-Minute Delay 	You may notice a few minutes delay in starting if you try to restart the Zonline too soon after turning it off or if you adjust the thermostat right after the compressor has shut off. This is due to a built-in restart protector for the compressor that causes a 3-minute delay.
SILENCE	The compressor shuts off during the defrost cycle. Full resistance heat comes on during the defrost cycle to maintain room comfort.
COMPRESSOR PROTECT	To protect the compressor and prevent short cycling, the unit is designed to run for a minimum of 3 minutes, after the compressor starts at any thermostat setting.



If Something Goes Wrong

Before You Call For Service

Problem	Possible Causes	What to Do
Zoneline Doesn't Start	The unit is unplugged	<ul style="list-style-type: none">• Make sure the Zoneline plug is pushed completely into the outlet.
	The fuse is blown/circuit breaker is tripped	<ul style="list-style-type: none">• Check the house fuse/circuit breaker box and replace fuse or reset the breaker.
	The unit is waiting for the compressor overload protector to reset	<ul style="list-style-type: none">• This is normal. The Zoneline will start again after it resets.
	Power failure	<ul style="list-style-type: none">• If power failure occurs, set the mode control to STOP. When power is restored set the mode control to the desired setting. <p>There is a protective time delay (up to 3 minutes) to prevent tripping of the compressor overload. For this reason, the unit may not start normal heating or cooling for 3 minutes after it is turned back on.</p>
Zoneline Does Not Cool or Heat as it Should	Indoor airflow is restricted	<ul style="list-style-type: none">• Make sure there are no curtains, blinds or furniture blocking the front of the Zoneline.
	Outdoor airflow is restricted or recirculated	<ul style="list-style-type: none">• Make sure the rear grille is not restricted. This can cause the unit to cycle off due to the compressor overload.
	The temp control may not be set high or low enough	<ul style="list-style-type: none">• Turn the control to a lower or higher setting. NOTE: The temperature limiter may be limiting the temperature range.
	The air filter is dirty	<ul style="list-style-type: none">• Clean the filter at least every 30 days.
	The room may have been hot or cold	<ul style="list-style-type: none">• When the Zoneline is first turned on you need to allow time for the room to cool down or warm up.
	Outdoor air is entering the room	<ul style="list-style-type: none">• Set the vent control to the CLOSE position.



If Something Goes Wrong

Before You Call For Service

Problem	Possible Causes	What to Do
Burning Odor at the Start of Heating Operation	Dust is on the surface of the heating element	<ul style="list-style-type: none">• This can cause a “burning” odor at the beginning of the heating operation. This odor should quickly fade.
The Air is Not Always Cool or Hot During Operation	The heat pump is not producing hot air	<ul style="list-style-type: none">• This is normal. The heat pump will produce warm air but not as hot as air produced when the higher-cost electric heat is used.
	The fan switch may be set at continuous fan (down)	<ul style="list-style-type: none">• This causes the fan to blow room temperature air even when the compressor or heater cycles off. The continuous air movement provides better overall temperature control.
The Air Does Not Feel Warm Enough During Heating Operation	The heat pump alone produces air that feels cooler than desired	<ul style="list-style-type: none">• Use the Electric Heat Option. This turns off the heat pump and warms with electric heat only. <p>NOTE: Use of this option will result in increased energy consumption.</p>

GE Service Numbers

We'll be there!



GE Answer Center®

800.626.2000

**TDD
800-833-4322**

Open 24 hours a day,
7 days a week.

On-Site Repair Service

**800-GE-CARES
(800-432-2737)**

We provide expert repair service,
scheduled at a time that's
convenient for you.

Our factory-trained technicians
know your air conditioner inside and
out—so most repairs can be handled
in just one visit.

Parts and Accessories

800-626-2002

Individuals qualified to service
their own air conditioner can have
parts or accessories sent directly
to their home.

VISA, MasterCard and Discover
cards are accepted.

**Care and cleaning instructions con-
tained in this manual cover proce-
dures to be performed by any user.
Other servicing generally should be
referred to qualified service person-
nel. Caution must be exercised,
since improper servicing may cause
unsafe operation.**

Further Service

If for some reason you
are not happy with the
service you receive, here
are three steps to follow
for further help.

First, contact the people who ser-
viced your air conditioner. Explain
why you are not pleased.

Next, if you are still not pleased,
write all the details—including
your phone number—to:

Consumer Relations
GE Appliances,
Louisville, KY 40225

Finally, if your problem is still
not resolved, write:

Major Appliance
Consumer Action Program
20 North Wacker Drive
Chicago, IL 60606

ZONELINE WARRANTY

Staple sales slip or cancelled check here.
Proof of original purchase date is needed
to obtain service under warranty.

All warranty service will be provided
by our Factory Service Centers, or an
authorized Customer Care® technician.

For service in the U.S., call
800-GE-CARES.

For service in Canada, call
1-800-361-3400.

What Is Covered

FULL ONE-YEAR WARRANTY

For one year from date of original purchase, we will provide, free of charge, parts and service labor on site to repair or replace *any part of the Zoneline* that fails because of a manufacturing defect.

FULL FIVE-YEAR WARRANTY

For five years from the date of original purchase, we will provide, free of charge, parts and on-site service labor to repair or replace *any part of the sealed refrigerating system* (the compressor, condenser, evaporator and all connecting tubing) that fails because of a manufacturing defect.

LIMITED 2ND THROUGH 5TH YEAR PARTS WARRANTY

For the second through the fifth year from date of original purchase, General Electric will provide, free of charge, parts that fail as a result of a manufacturing defect. Parts covered are fan motors, switches, thermostat, heater, heater protectors, compressor overload, solenoids, circuit boards, auxiliary controls, thermistors, Freeze Sentinel, frost controls, ICR pump, capacitors, varistors, and indoor blower bearing. This is a limited parts-only warranty, and does not include labor or transportation to and from the service shop.

What Is Not Covered

- Service trips to your site to teach you how to use the product.
- Improper installation.
If you have an installation problem, or if the air conditioner is of improper cooling capacity for the intended use, contact your dealer or installer. You are responsible for providing adequate electrical connecting facilities.
- Replacement of fuses or resetting of circuit breakers.
- In commercial locations, labor necessary to move the unit to a location where it is accessible for service by an individual technician.
- Failure of the product resulting from modifications to the product or due to unreasonable use including failure to provide reasonable and necessary maintenance.
- Failure or damage resulting from corrosion due to installation in an environment containing corrosive chemicals.
- Failure or damage resulting from corrosion due to installation in a coastal environment, except for models treated with special factory-applied anti-corrosion protection as designated in the model number.
- Damage to product caused by improper power supply voltage, accident, fire, floods or acts of God.
- Incidental or consequential damage to personal property caused by possible defects with this air conditioner.

Warrantor: General Electric Company, Louisville, KY 40225

This warranty is extended to the original purchaser and any succeeding owner for products purchased for use within the USA and Canada. In Alaska, the warranty excludes the cost of shipping or service calls to your site.

Some states do not allow the exclusion or limitation of incidental or consequential damages. This warranty gives you specific legal rights, and you may also have other rights which vary from state to state. To know what your legal rights are in your state, consult your local or state consumer affairs office or your state's Attorney General.