

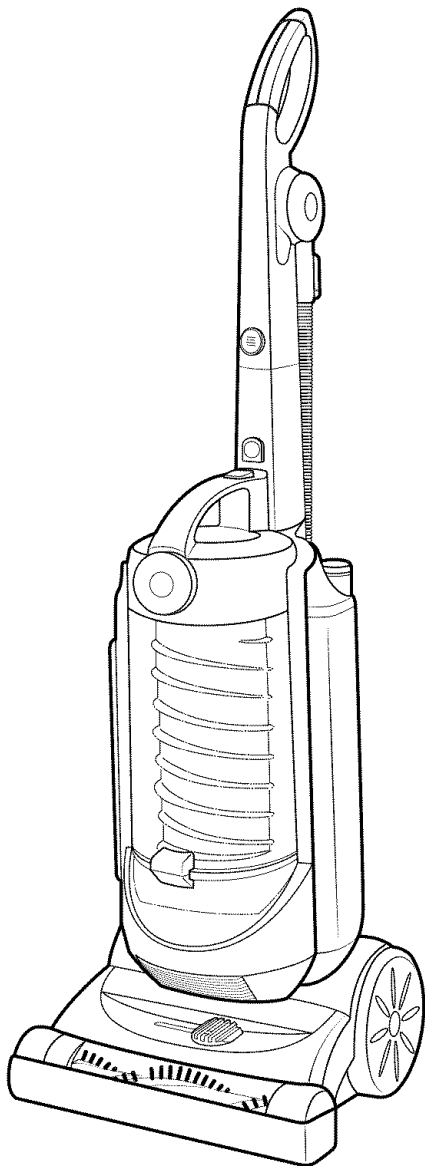

INSTRUCTION MANUAL
VACUUM CLEANER

FM760



Contents

IMPORTANT SAFETY INSTRUCTIONS1
NAME OF EACH PART3
PREPARATION BEFORE USE4
USING THE VACUUM CLEANER6
USING THE ATTACHMENTS8
EMPTYING THE DUST COMPARTMENT9
CLEANING THE FILTERS10
CLEARING BLOCKAGES IN THE
SUCTION HOSE AND CLEANING THE11
AGITATOR ASSEMBLY
REPLACEMENT INSTRUCTIONS12
TROUBLESHOOTING16
REPLACEMENT PARTS16
LIMITED WARRANTY17

HOUSEHOLD USE ONLY

IMPORTANT SAFETY INSTRUCTIONS

When using an electrical appliance, basic precautions should always be followed, including the following.

READ ALL INSTRUCTIONS BEFORE USING THIS VACUUM CLEANER

WARNING - To reduce the risk of fire, electric shock or injury:

1. Do not leave the vacuum cleaner when plugged in. Unplug it from the outlet when not in use and before servicing.
2. Do not use outdoors or on wet surfaces.
3. Do not allow it to be used as a toy. Close attention is necessary when used by or near children or infirmed persons.
4. Use only as described in this manual. Use only the manufacturer's recommended attachments.
5. Do not use with a damaged cord or plug. If the vacuum cleaner is not working as it should, or if it has been dropped, damaged, left outdoors or dropped into water, return to FANTOM at 94 Main Mill street, Door 16, Plattsburgh, NY 12901.
6. Do not pull or carry by the cord, use the cord as a handle, close a door on the cord, or pull the cord around sharp edges or corners. Do not run the vacuum cleaner over the cord. Keep the cord away from heated surfaces.
7. Do not unplug by pulling on the cord. To unplug, grasp the plug, not the cord.
8. Do not handle the plug or the vacuum cleaner with wet hands.
9. Do not put any objects into the openings. Do not use with any opening blocked: keep free of dust, lint, hair and anything that may reduce air flow.
10. Keep hair, loose clothing, fingers and all the parts of your body away from openings and moving parts.
11. Do not pick up anything that is burning or smoking, such as cigarettes, matches or hot ashes.
12. Do not use without dust compartment and filters in place.
13. Turn off all controls before unplugging.
14. Use extra care when cleaning on stairs.
15. Do not use to pick up flammable or combustibile liquids such as gasoline, or use in areas where they may be present.

16. Do not touch the agitator while it is spinning.
17. Do not place any heavy items on top of the vacuum cleaner.
18. Do not step on the hose or pull it too strongly.
19. Do not pick up items such as pieces of waste paper or cloth which look as though they may cause the hose to become blocked.
20. Do not clean or store the vacuum cleaner in places where there are high temperatures.
21. Store the vacuum cleaner away from excessive humidity.
22. When carrying the vacuum cleaner, hold it by the carrying handle.
23. Before servicing the vacuum cleaner, allow all metal parts to cool first.
24. Always place foot on handle release when adjusting the handle position of the vacuum cleaner.
25. If the supply cord of this appliance is damaged, it must only be replaced by FANTOM , because special purpose tools are required.

SAVE THESE INSTRUCTIONS

This vacuum cleaner is intended for household use only.

Note to user concerning attachment plug:

To reduce the risk of electric shock, this appliance has a polarized plug (one blade is wider than the other). This plug will fit in a polarized outlet only one way. If the plug does not fit fully in the outlet, reverse the plug. If it still does not fit, contact a qualified electrician to install the proper outlet. Do not change the plug in any way.

NAME OF EACH PART

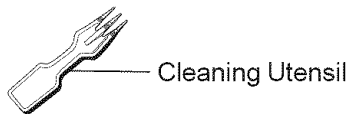
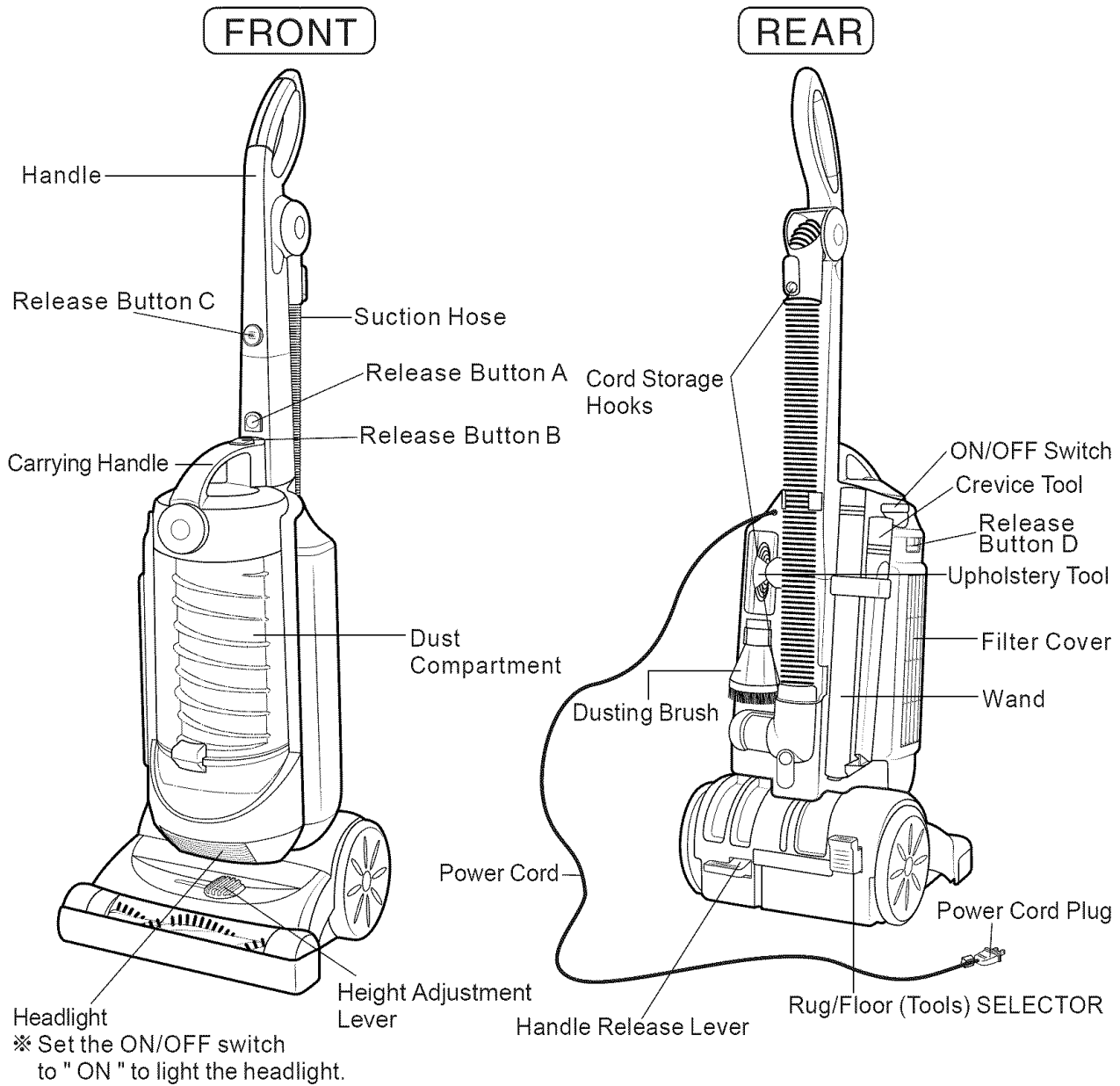

WARNING:

Operate vacuum cleaner only at the voltage specified on name plate.

PREPARATION BEFORE USE

Caution: Do not connect the power cord plug to the wall outlet until assembly is completed.

Attaching the handle

1 Set the vacuum cleaner to the upright position.

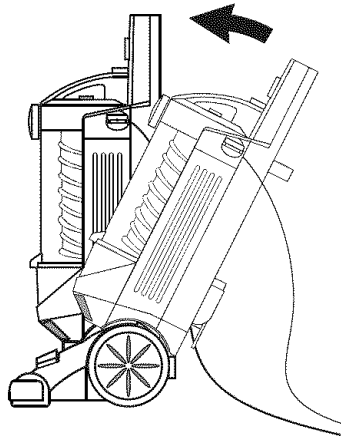

2 Insert the handle as shown in the illustration.

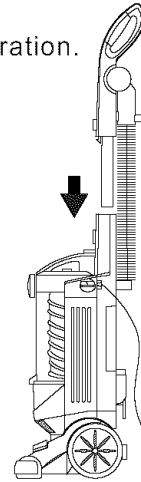

Attaching the suction hose & attachments

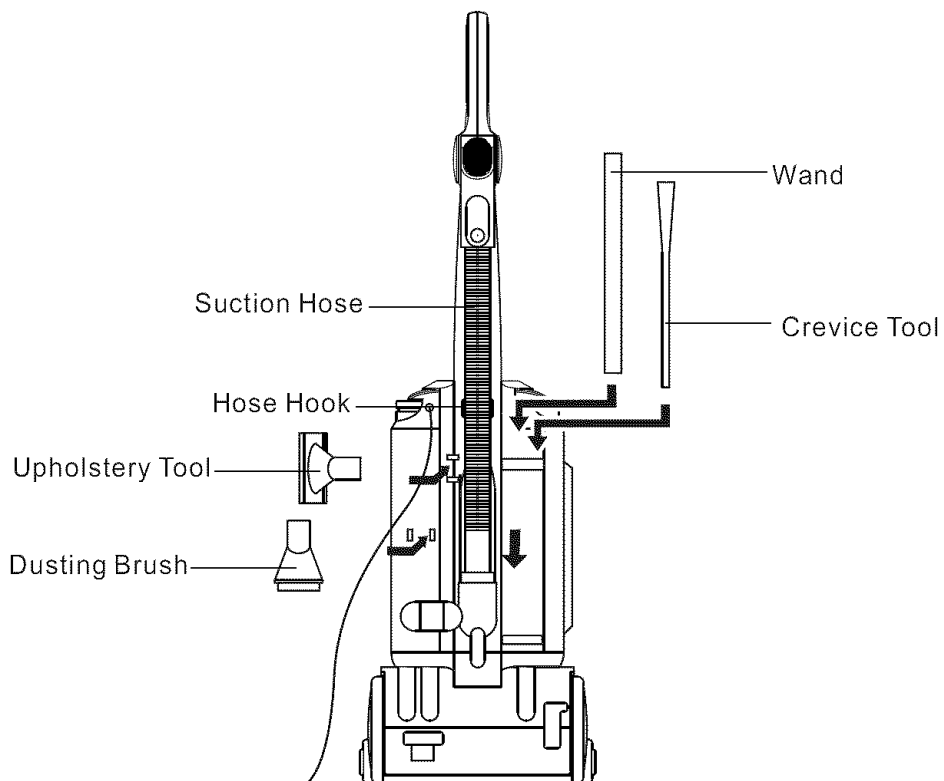

PREPARATION BEFORE USE

WINDING THE POWER CORD

- 1 Hook the power cord over the clip which is located on the upper cord storage hook as shown.

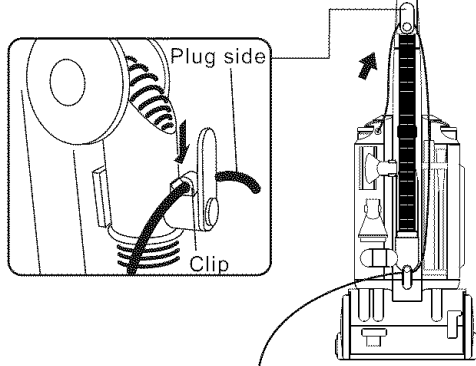

- 2 Wind the power cord around the cord storage hooks.

- Secure the power cord plug on the power cord.

Cord Storage Hooks

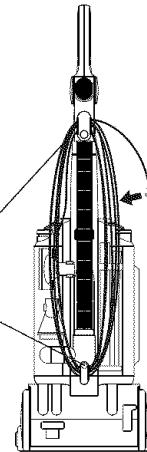

RELEASING THE POWER CORD

- 1 Rotate the upper cord storage hook downward.

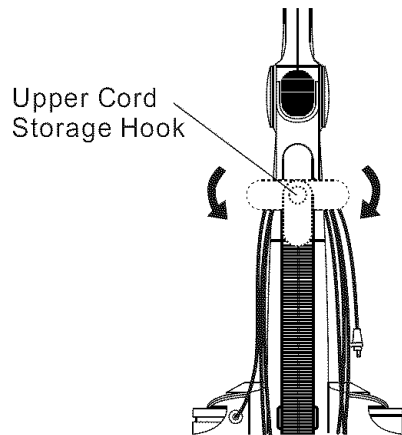

- 2 Return the hook to the upright position before attempting to rewind the power cord.

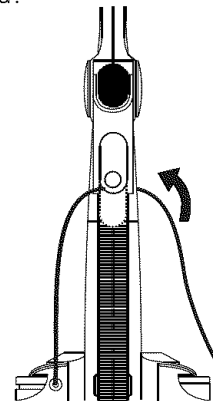

INSERTING THE POWER CORD PLUG

WARNING: To reduce the risk of electric shock, this appliance has a polarized plug (one blade is wider than the other). This plug will fit in a polarized outlet only one way. If the plug does not fit fully in the outlet, reverse the plug. If it still does not fit, contact a qualified electrician to install the proper outlet. Do not modify the plug in any way.

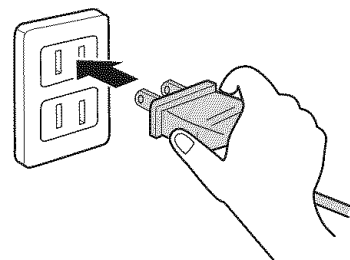

USING THE VACUUM CLEANER

ON/OFF SWITCH

- Start or stop vacuum cleaner by pushing on the switch.

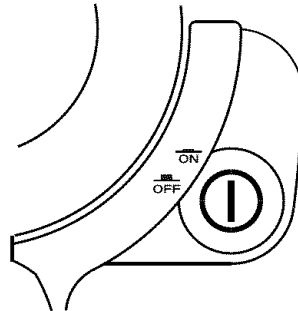

ADJUSTING THE HANDLE

The handle of this vacuum cleaner can be set to one of three positions - Upright, Normal or Parallel. Place your foot on handle release lever as shown and pull back on the handle until it releases from its upright position.

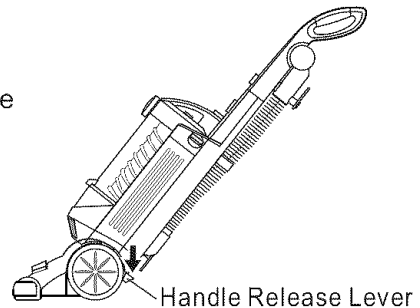

Upright position

The handle is normally locked in this position for storage or when using the attachments. Push the handle forward until it locks.

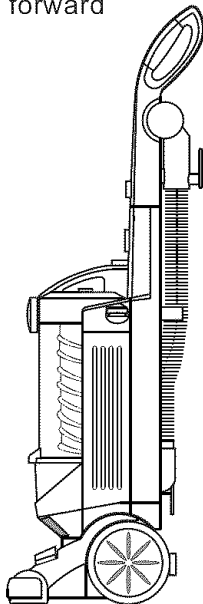

Normal position

This position is used for normal cleaning.

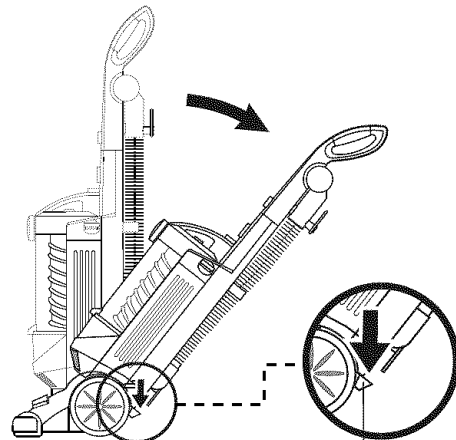

Parallel position

Handle Release Lever

This position is used for cleaning under furniture.

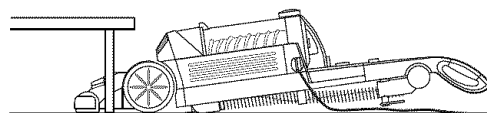

USING THE VACUUM CLEANER

HEIGHT ADJUSTMENT LEVER

Height Adjustment Lever

● The nozzle head can be adjusted to four different height settings.

Caution: Before using the height adjustment lever, please make sure the nozzle head is tilted backward from the floor.

Nozzle Head

CARPET Set the height adjustment to the appropriate carpet length.

HARD FLOOR Use the 3rd () height setting.

ATTACHMENTS Use the 4th () height setting.

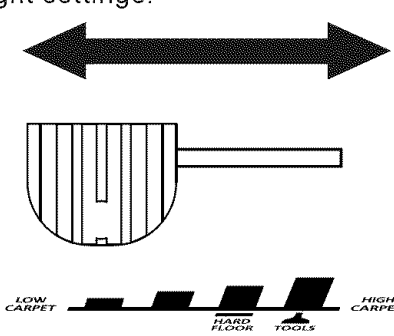

RUG/FLOOR (TOOLS) SELECTOR

The RUG/FLOOR(TOOLS) selector should only be adjusted while the vacuum cleaner is turned on and in the upright position.

1 When cleaning a rug or carpet, first turn the ON/OFF switch to the ON position, and then set the RUG/FLOOR(TOOLS) selector to the RUG position.

2 When cleaning a bare floor or when using one of the attachments, set the RUG/FLOOR (TOOLS) selector to the FLOOR position.

Caution: Do not change the setting of the RUG/FLOOR(TOOLS) selector while the vacuum cleaner is turned off.

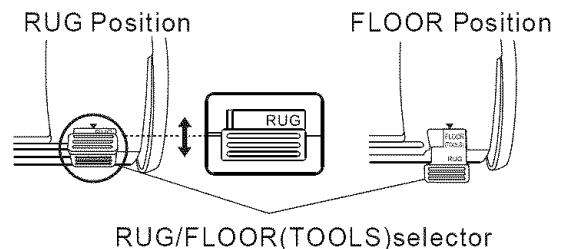

EDGE CLEANING

This vacuum cleaner is equipped with an "edge cleaning" function for cleaning carpet edges near baseboards and stationary furniture.

USING THE ATTACHMENTS

Caution: When using one of the attachments during cleaning, set the vacuum cleaner to the upright position.

- 1 Remove the attachments from the vacuum cleaner.
- 2 Press the release button C to disconnect the handle from the vacuum cleaner.

Caution:

When removing the attachments, pull them in the directions shown in the illustration. Pulling them in the wrong direction or pulling them forcefully may cause damage to the attachment clamp.

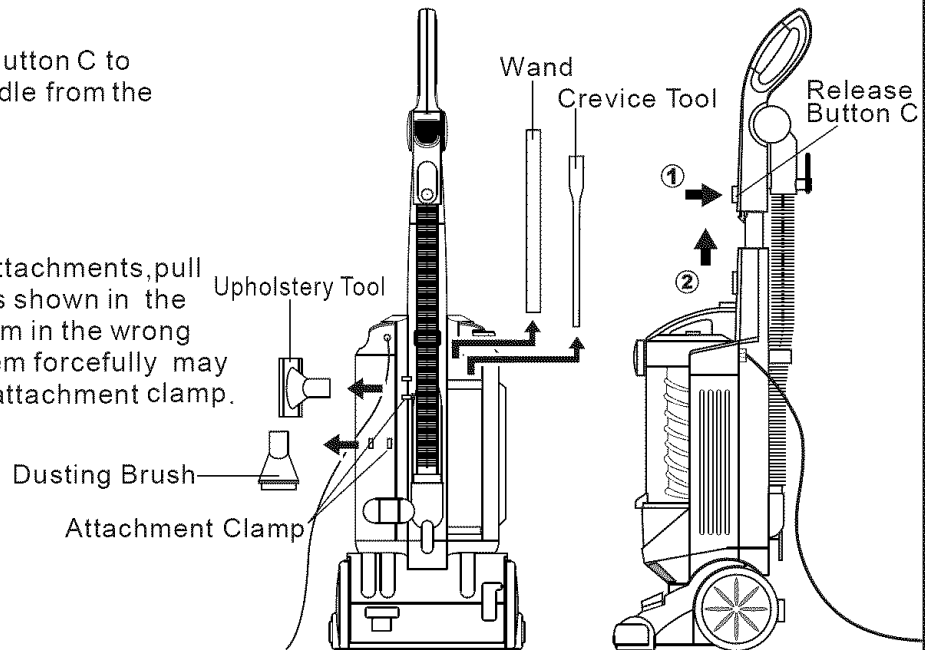

- 3 Attach the attachments on the handle.

• Attach the attachments as shown below.

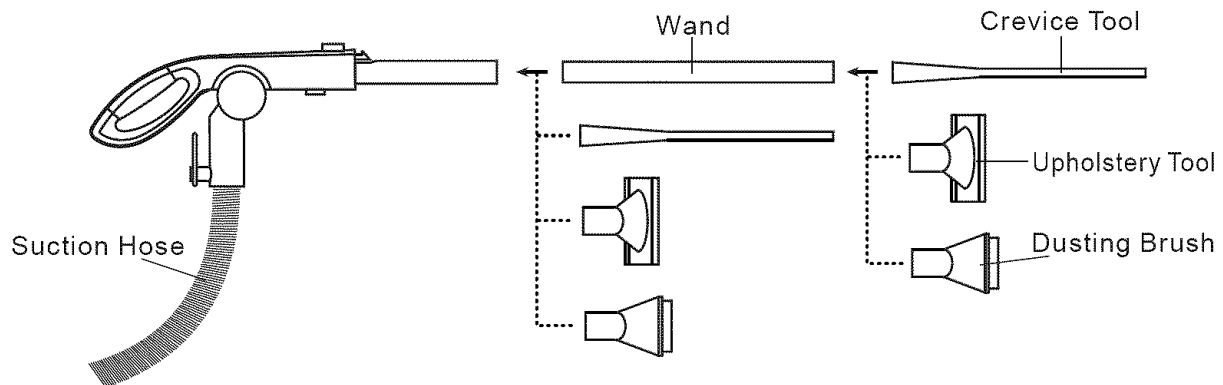

When you have finished using the attachments, replace them in their original positions as shown on page 4.

EMPTYING THE DUST COMPARTMENT

Caution: Be sure to turn the ON/OFF switch to the "OFF" position and disconnect the power cord from the wall outlet before cleaning.

- 1** Empty the dust compartment when contents reach the MAX mark.

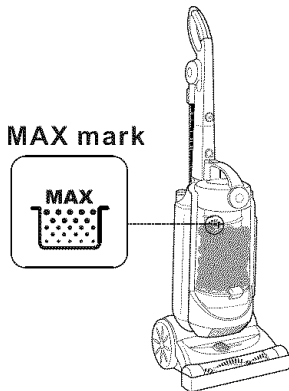

- 2** Press the release button A meanwhile press the release button B to remove the dust compartment.

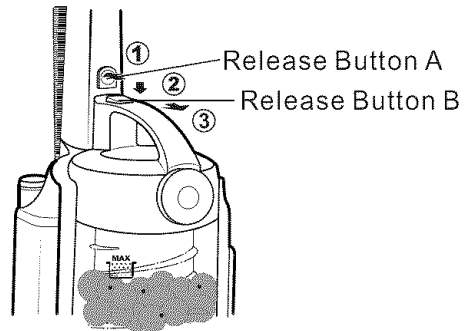

- 3** Press the release lever to open the trapdoor.

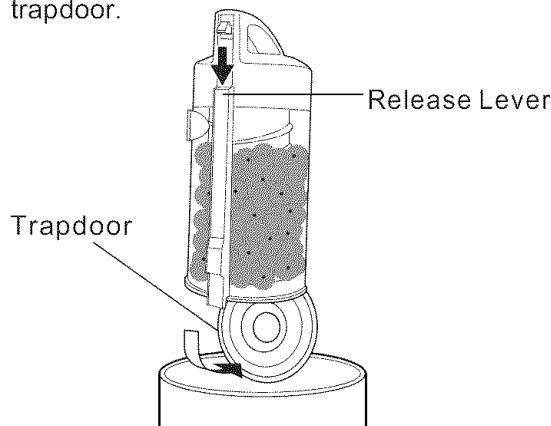

- 4** Turn the spinner handle several times in the direction shown to empty the dust compartment.

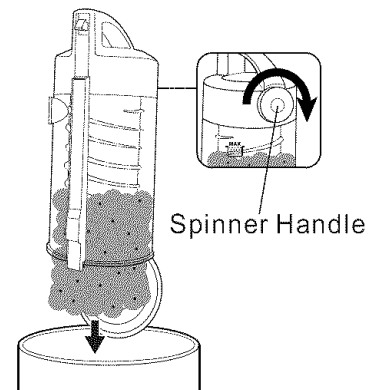

Reattaching the Dust Compartment

- 1** Close the trapdoor and insert the projection on the dust compartment into the groove on the main body.

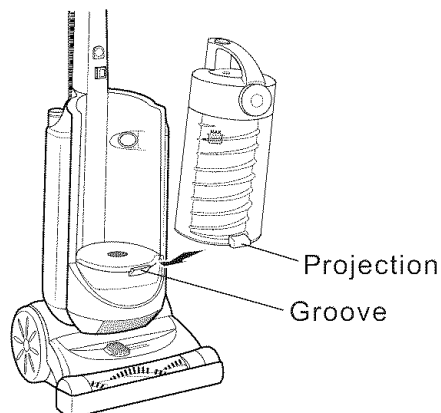

- 2** Push the dust compartment into the main body as shown to reattach.

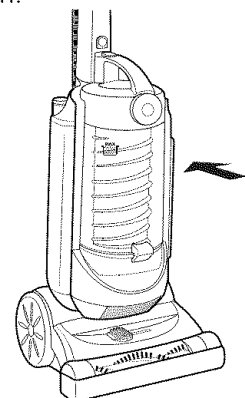

CLEANING THE FILTERS

1 Remove the dust compartment. (refer to page 9)

2 Set the dust compartment to the parallel position. Open the trapdoor, then push the release button E and pull out the main filter.

- The main filter and prefilter will be removed at the same time.

Caution: Do not push the release button E at the upright position. As this may drop or damage the main filter and prefilter.

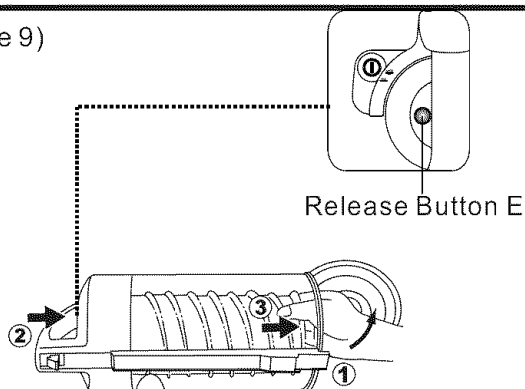

3 Clean the main filter and prefilter with a soft-bristled brush and rinse with cold water. Allow both items to dry completely.

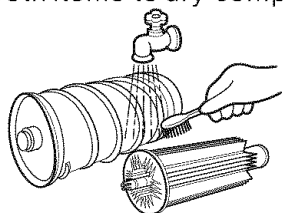

Caution:

- Do not use a hard-bristled brush to clean filters. This may result in damage to the filters.
- Do not attempt to dry with a hair dryer or by placing in a clothes dryer. Hot air may cause the filters to warp.

Cleaning Utensil

To maintain optimum suction power, the dust filter fins should be kept clean of dirt.

- Clean the filter fins free of dirt with the forked end of cleaning utensil as shown.

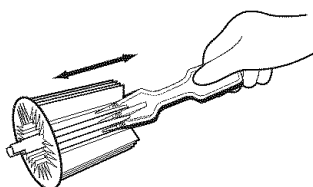

Reattaching the filters

1 Insert the main filter into the prefilter as shown.

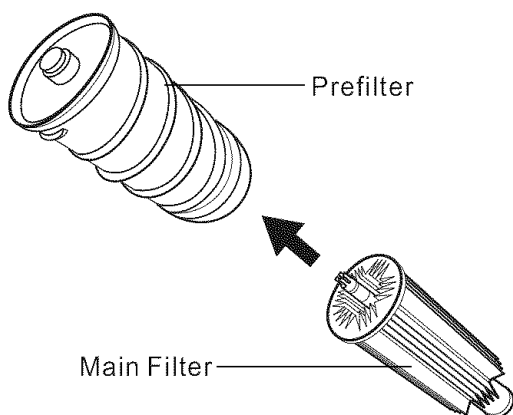

2 Hold onto the main filter and insert into the dust compartment.

- Align the ribs of the main filter to match the shape of the opening in the dust compartment and press firmly to insert.

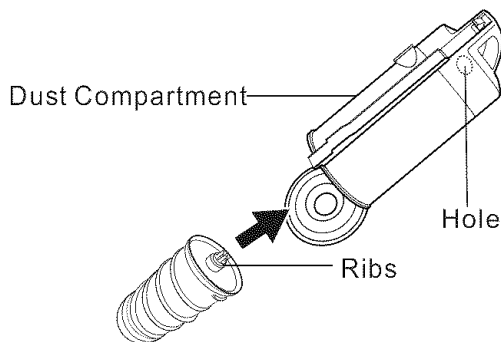

3 Close the trapdoor.

CLEARING BLOCKAGES IN THE SUCTION HOSE AND CLEANING THE AGITATOR ASSEMBLY

Caution: Be sure to turn the ON/OFF switch to the "OFF" position and disconnect the power cord from the wall outlet before clearing any blockages in the suction hose and cleaning the agitator assembly.

Clearing blockages in the suction hose

- 1 Set the vacuum cleaner to the upright position.
- 2 Remove the hose cuff from the suction inlet and then remove any blockages from the hose.
- 3 Pull the dust inspection cover away from body and push out the dust clogging the bypass tube assembly.
- 4 Reattach the hose cuff to the suction inlet, and the dust inspection cover to the bypass tube assembly. Now switch on the vacuum cleaner to check that the blockage has been properly cleared. If the hose is still blocked, the suction force will be weak.

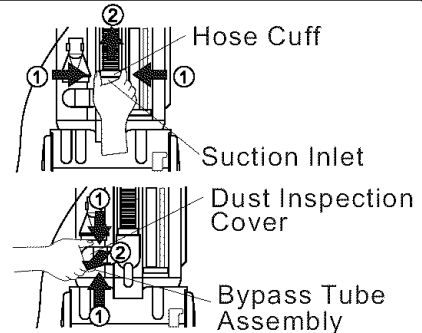

Clearing blockages in the nozzle head

- 1 Remove the bottom plate (refer to page 14)
- 2 Remove any blockages from the nozzle head.
- 3 Reattach the bottom plate to the nozzle head, and then operate the vacuum cleaner to check that the blockage has been properly cleared. If the nozzle head is still blocked, the suction force will be weak.

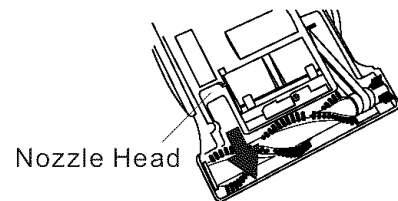

Cleaning the blockage in the nozzle air inlet pipe

If the nozzle head still appears to be blocked, please clear the blockage in the nozzle air inlet pipe.

- 1 Press release button F to remove the upper case.
- 2 Remove the blockage in the nozzle air inlet pipe.
- 3 Reattach the vacuum cleaner.

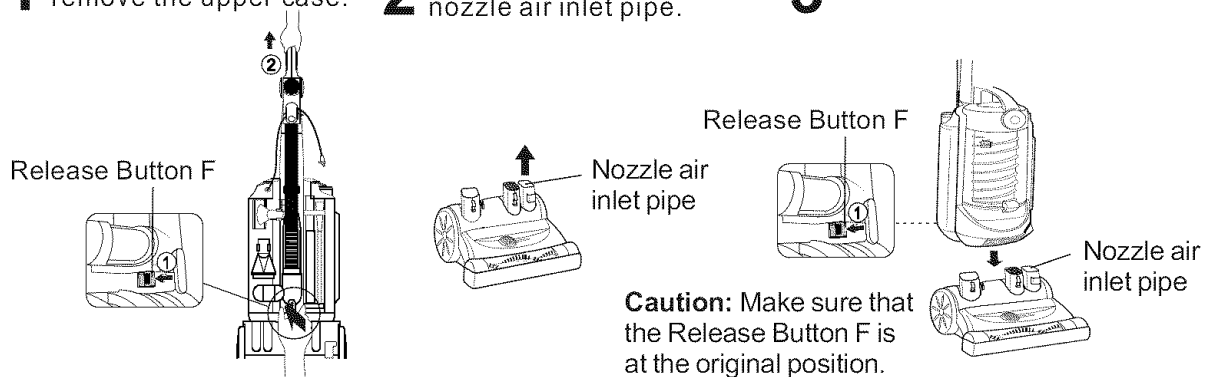

Cleaning the agitator assembly

When threads get caught in the agitator assembly, clean the assembly.

- Remove the bottom plate (refer to page 14). Remove threads caught in the assembly by cutting them with scissors.

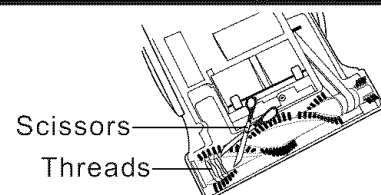

REPLACEMENT INSTRUCTIONS

Caution: Be sure to turn the ON/OFF switch to the "OFF" position and disconnect the power cord from the wall outlet before replacing any of the parts below.

REPLACING THE HEADLIGHT LAMP

- 1 Set the vacuum cleaner to the parallel position.

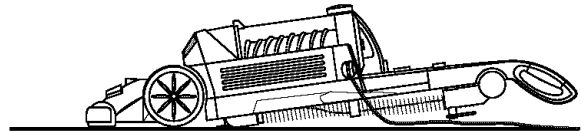

- 2 Loosen the screws to remove the lens.

- 3 When removing the headlight lamp, be careful not to pull on the headlight lamp wiring.

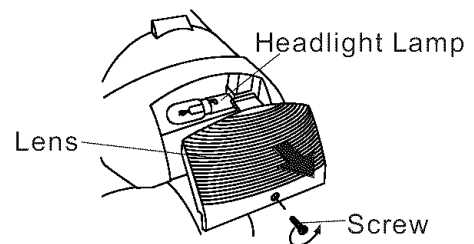

- 4 Remove the lamp by pushing it gently in the direction of the arrow and then turning it counterclockwise.

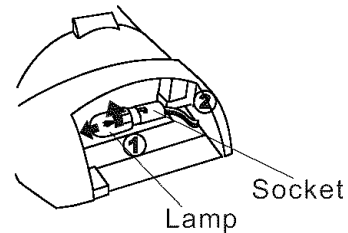

- 5 Push a new lamp gently into the socket and turn it clockwise to tighten it. Use a standard bayonet base appliance lamp rated at 120V and 15W (LAMP MAX.15W).

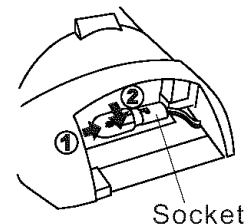

Caution: Be careful not to clamp the headlight lamp wiring.

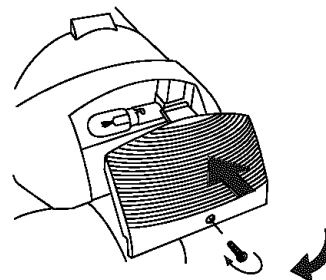

- 6 Reattach the lens and fasten the screws.

REPLACEMENT INSTRUCTIONS

Caution: Be sure to turn the ON/OFF switch to the "OFF" position and disconnect the power cord from the wall outlet before replacing any of the parts below.

REPLACING THE FLAT BELT

- 1** Remove the bottom plate.
(refer to page 14)
- 2** Lift out the agitator assembly, and then remove the flat belt from the motor shaft and the agitator pulley.

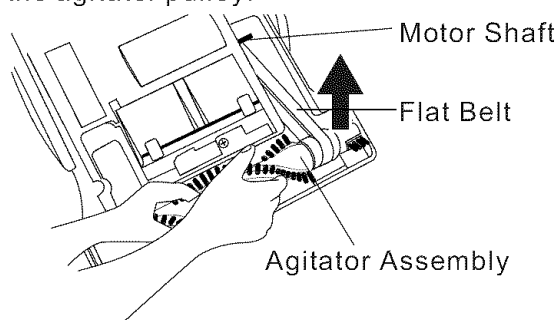

- 3** Place a new flat belt onto the motor shaft and pulley.

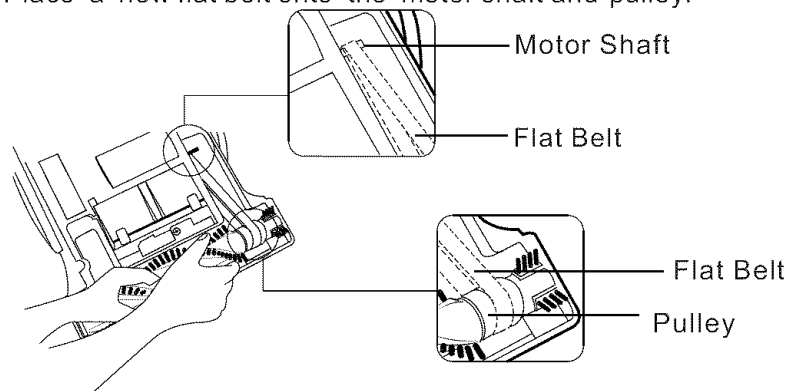

- 4** Place the agitator assembly into the grooves in the nozzle head, making sure that the new flat belt slides securely into the guide.

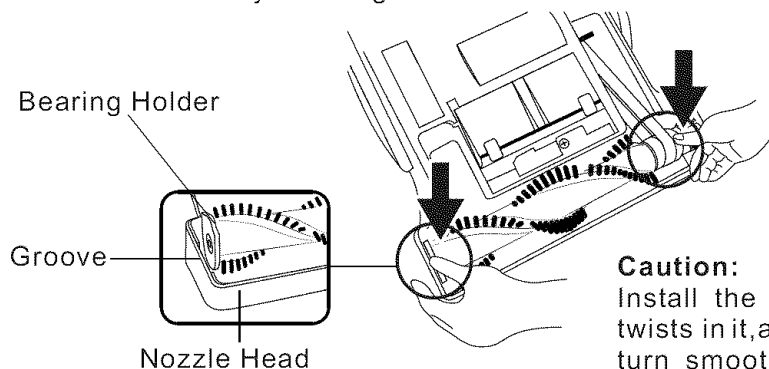

Caution:
Install the flat belt so that it has no twists in it, and so that all components turn smoothly.

- 5** Reattach the bottom plate
(refer to page 14)

REPLACEMENT INSTRUCTIONS

REMOVING THE BOTTOM PLATE

- 1 Set the vacuum cleaner to the parallel position and turn it over.
- 2 Slide the latch in the direction of the arrow.
- 3 Remove the bottom plate by pulling the tabs as illustrated.

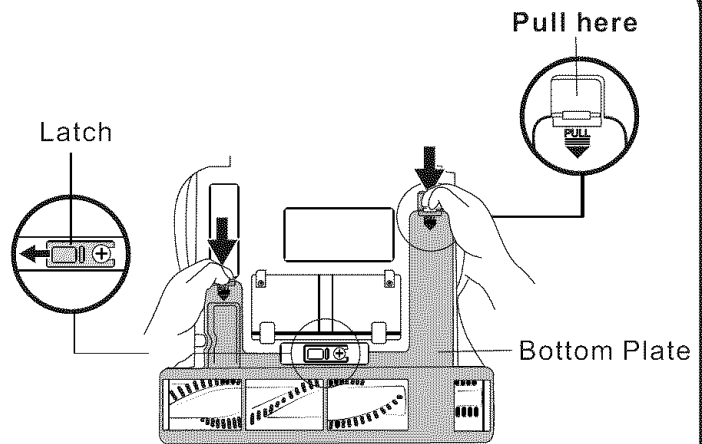

REATTACHING THE BOTTOM PLATE

- 1 Insert the projection on the bottom plate into the groove on the nozzle head and set the bottom plate in place.
- 2 Push the bottom plate as shown.
- 3 Slide the latch in the direction shown.
- 4 Turn the vacuum over and place in the upright position.

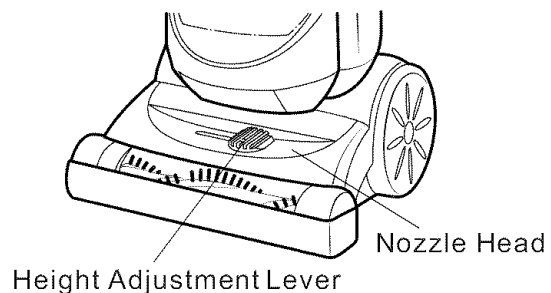
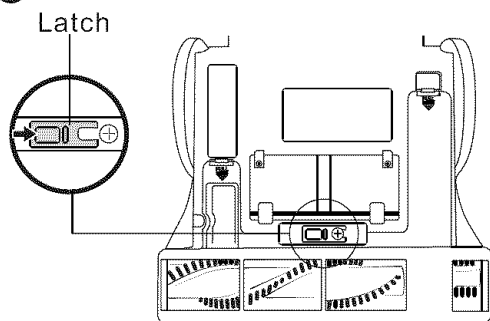
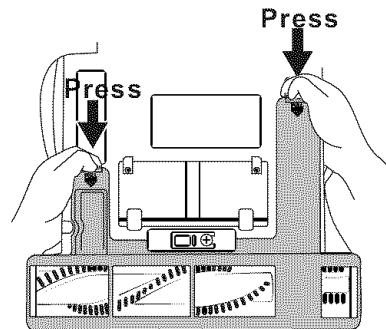
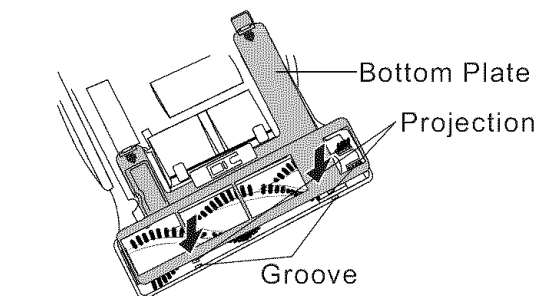

REPLACEMENT INSTRUCTIONS

REPLACING THE HEPA FILTER

Under normal usage, the HEPA Filter will not require replacement; however, vacuuming large amounts of extremely fine dust, powder or similar material over a long period of time may decrease airflow performance through the filter. If this occurs, it may become necessary to replace the HEPA Filter. Only use genuine FANTOM replacement filters.

- 1** Press the release button D at points ① and pull the filter cover away from the vacuum cleaner.

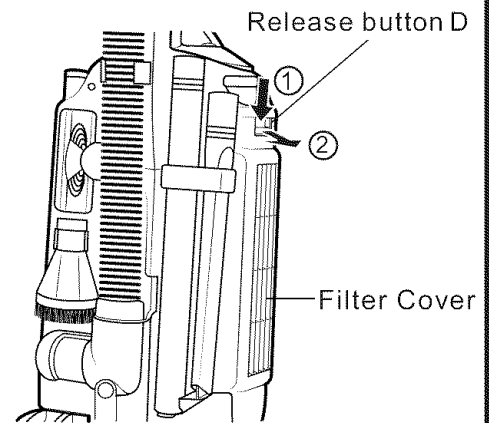

- 2** Remove the HEPA filter.

Caution:

- Do not attempt to wash the HEPA filter. Always replace the old filter with a new one.

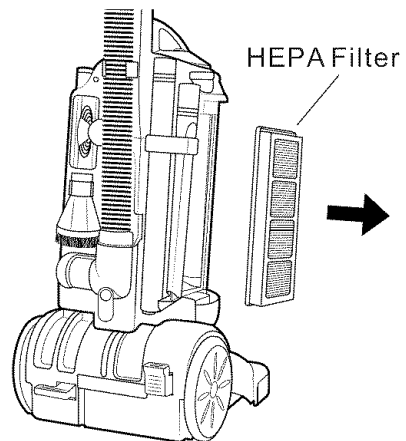

- 3** Insert a new HEPA filter with the seal to the inside of the vacuum cleaner. Reattach the filter cover.

Caution:

- Be sure that seal on the HEPA filter is inserted towards the inside of the vacuum cleaner.
- The filter cover should be correctly oriented when it is reattached. Do not reattach it upside down.

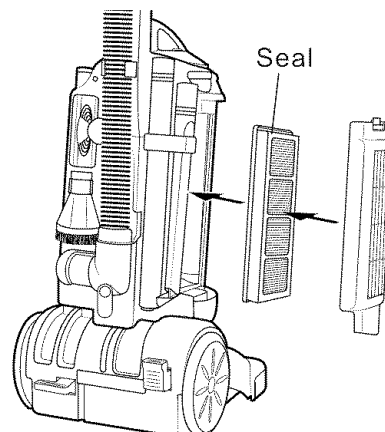

TROUBLESHOOTING

If there is a problem with the vacuum cleaner, carry out the following checks to find the cause. If the problem still persists after the checks have been made, do not use the vacuum cleaner to prevent the possibility of an accident occurring. Turn the ON/OFF switch to the "OFF" position, disconnect the power cord from the wall outlet, and contact FANTOM Customer Service at 1-800-275-9251. Or visit our website at www.fantom.com

Problem	Cause	Remedy
The motor does not operate when the ON/OFF switch is set to the "ON" position.	<ul style="list-style-type: none"> • The power cord plug is not securely inserted into the wall outlet. 	<ul style="list-style-type: none"> • Insert the power cord plug securely into the wall outlet.(refer to page 5)
Suction force is weak.	<ul style="list-style-type: none"> • The dust compartment is full. • The suction hose is blocked. • The nozzle head is blocked. • The filters are dirty. • The nozzle air inlet pipe is blocked. 	<ul style="list-style-type: none"> • Empty the dust compartment. (refer to page 9) • Remove the blockage. (refer to page 11) • Remove the blockage. (refer to page 11) • Clean the filters. (refer to page 10) • Remove the blockage. (refer to page 11)
The agitator does not operate.	<ul style="list-style-type: none"> • The flat belt is worn or broken. 	<ul style="list-style-type: none"> • Replace the flat belt. (refer to page 12)

TO ORDER REPLACEMENT FILTERS CALL 1-800-275-9251



ONE (1) YEAR LIMITED WARRANTY

FANTOM warrants this product to be free from defects in material and workmanship for a period of one (1) year from the date of the original purchase, when utilized for normal household use, subject to the following conditions, exclusions and exceptions.

If your appliance fails to operate properly while in use under normal household conditions within the warranty period, return the complete appliance and accessories, freight prepaid to

In US: FANTOM, 94 Main Mill Street, Door 16, Plattsburgh N.Y. 12901

If the appliance is found by FANTOM to be defective in material or workmanship, FANTOM will repair or replace it free of charge. Proof of purchase date and \$19.95 to cover the cost of return shipping and handling must be included. *

Non-durable parts including, without limitation, dust cup filters, filters, belts, brushes and electrical parts which normally require replacement are specifically excluded from warranty.

The liability of FANTOM is limited solely to the cost of the repair or replacement of the unit at our option. This warranty does not cover normal wear of parts and does not apply to any unit that has been tampered with or used for commercial purposes. This limited warranty does not cover damage caused by misuse, abuse, negligent handling or damage due to faulty packaging or mishandling in transit. This warranty does not cover damage or defects caused by or resulting from damages from shipping or repairs, service or alterations to the product or any of its parts, which have been performed by a repair person not authorized by **FANTOM**.

This warranty is extended to the original purchaser of the unit and excludes all other legal and/or conventional warranties. The responsibility of FANTOM if any, is limited to the specific obligations expressly assumed by it under the terms of the limited warranty. **In no event** is FANTOM liable for incidental or consequential damages of any nature whatsoever. Some states do not permit the exclusion or limitation of incidental or consequential damages, so the above may not apply to you.

This warranty gives you specific legal rights, and you may also have other rights which vary from state to state.

***Important: Carefully pack item to avoid damage in shipping. Be sure to include proof of purchase date and to attach tag to item before packing with your name, complete address and phone number with a note giving purchase information, model number and what you believe is the problem with item. We recommend you insure the package (as damage in shipping is not covered by your warranty). Mark the outside of your package "ATTENTION CUSTOMER SERVICE".**

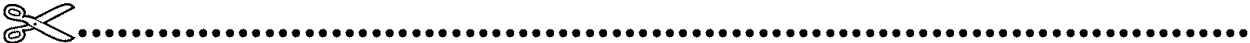

OWNERSHIP REGISTRATION CARD

Please fill out and mail the product registration card within ten (10) days of purchase. The registration will enable us to contact you in the unlikely event of a product safety notification. By returning this card you acknowledge to have read and understood the instructions for use, and warnings set forth in the accompanying instructions.

RETURN TO **FANTOM**, 94 Main Mill Street, Door 16, Plattsburgh, N.Y. 12901

Model FM760
Appliance model

Date purchased Name of store

Owner's name

Address City State Zip Code