



Installation Instructions

NOTE: Read the entire instruction manual before starting the installation.

TABLE OF CONTENTS

	PAGE
SAFETY CONSIDERATIONS	1
INTRODUCTION	1
HEATER PACKAGES	1
INSTALLATION	1
Check Equipment	1
Mount Unit	1
Air Ducts	4
Electrical Connections	6
Refrigerant Tubing	8
Refrigerant Flow-Control Device	9
Condensate Drains	9
Accessories	10
Sequence of Operation	10
START-UP PROCEDURES	10
CARE AND MAINTENANCE	10

SAFETY CONSIDERATIONS

Improper installation, adjustment, alteration, service, maintenance, or use can cause explosion, fire, electrical shock, or other conditions which may cause personal injury or property damage. Consult a qualified installer, service agency, or your distributor or branch for information or assistance. The qualified installer or agency must use factory-authorized kits or accessories when modifying this product. Refer to the individual instructions packaged with kits or accessories when installing.

Follow all safety codes. Wear safety glasses and work gloves. Use quenching cloth for brazing operations. Have fire extinguisher available. Read these instructions thoroughly and follow all warnings or cautions attached to the unit. Consult local building codes and National Electrical Code (NEC) for special requirements.

Recognize safety information. This is the safety-alert symbol . When you see this symbol on the unit and in instruction manuals, be alert to the potential for personal injury.

Understand the signal words DANGER, WARNING, CAUTION, and NOTE. These words are used with the safety-alert symbol. DANGER identifies the most serious hazards which **will** result in severe personal injury or death. WARNING signifies hazards which **could** result in personal injury or death. CAUTION is used to identify unsafe practices which **may** result in minor personal injury or product and property damage. NOTE is used to highlight suggestions which **will** result in enhanced installation, reliability, or operation.

WARNING

ELECTRICAL SHOCK HAZARD

Failure to follow this warning could result in personal injury or death.

Before installing or servicing unit, always turn off all power to unit. There may be more than one disconnect switch. Turn off accessory heater power, if applicable.

INTRODUCTION

Model PF1MNC Fan Coil units are designed for flexibility and can be used for upflow, horizontal, or downflow applications. These units are designed to meet the new low air leak requirements. For water management, special attention is paid to the condensate pan and drain connection area. These units are available for systems of 18,000 through 60,000 Btuh nominal cooling capacity. Factory-authorized electric heater packages are available in sizes 3 through 30 kW. See Product Data literature for available accessory kits.

HEATER PACKAGES

This unit may or may not be equipped with an electric heater package. For units not equipped with factory installed heat, a factory-approved, field-installed, UL-listed heater package is available from your equipment supplier. See unit rating plate for a list of factory-approved heaters. Heaters that are not factory approved could cause damage which would not be covered under the equipment warranty. If fan coil contains a factory-installed heater package, minimum circuit ampacity (MCA) and maximum fuse/breaker may be different than units with the same size field-installed accessory heater. The difference is not an error and is due to calculation differences per UL guidelines.

INSTALLATION

Step 1—Check Equipment

Unpack unit and move to final location. Remove carton taking care not to damage unit.

Inspect equipment for damage prior to installation. File claim with shipping company if shipment is damaged or incomplete. Locate unit rating plate which contains proper installation information. Check rating plate to be sure unit matches job specifications.

Step 2—Mount Unit

Unit can stand or lie on floor, or hang from ceiling or wall. Allow space for wiring, piping, and servicing unit.

IMPORTANT: When unit is installed over a finished ceiling and/or living area, building codes may require a field-supplied secondary condensate pan to be installed under the entire unit. Some localities may allow, as an alternative, the running of a

separate, secondary condensate line. Consult local codes for additional restrictions or precautions.

A. Upflow Installation

If return air is to be ducted through a floor, set unit on floor over opening and use 1/8- to 1/4-in. thick fireproof resilient gasket between duct, unit, and floor.

Side return is a field option on slope coil models. Cut opening per dimensions. (See Fig. 1.) A field-supplied bottom closure is required.

B. Downflow Installation

⚠ CAUTION

UNIT OR PROPERTY DAMAGE HAZARD

Failure to follow this caution may result in product or property damage.

The conversion of the fan coil to downflow requires special procedures for the condensate drains on both A-coil and slope units. The vertical drains have an overflow hole between the primary and secondary drain holes. This hole is plugged for all applications except downflow, but must be used for downflow. During the conversion process, remove the plastic cap covering the vertical drains only and discard. Remove the plug from the overflow hole and discard. At completion of the downflow installation, caulk around the vertical pan fitting to door joint to retain the low air leak performance of the unit.

In this application, field conversion of the evaporator is required using accessory downflow kit along with an accessory base kit. Use fireproof resilient gasket, 1/8- to 1/4-in. thick, between duct, unit, and floor.

NOTE: To convert units for downflow applications, refer to Installation Instructions supplied with kit for proper installation.

For slope fan coils, use kit Part No. KFADC0201SLP. For A-coils, use kit Part No. KFADC0401ACL. Use fireproof resilient gasket, 1/8- to 1/4-in. thick, between duct, unit, and floor.

NOTE: Gasket kit number KFAHD0101SLP is also required for all downflow applications to maintain low air leak/low sweat performance.

C. Horizontal Installation

Units must not be installed with access panels facing up or down. Units are factory built for horizontal left installation. (See Fig. 2 and 3.) When suspending unit from ceiling, dimples in casing indicate suitable location of screws for mounting metal support straps. (See Fig. 2.)

For horizontal applications having high return static and humid return air, the Water Management Kit (KFAHC0125AAA) may need to be used to assist in the water management.

⚠ CAUTION

PROPERTY DAMAGE HAZARD

Failure to follow this caution may result in product or property damage.

For optimum condensate drainage performance in horizontal installations, unit should be leveled along its length and width.

NOTE: Modular units (sizes 060 and 061) can be disassembled and components moved separately to installation area for reassembly. This process accommodates small scuttle holes and limiting entrances to installation sites. (See Fig. 4.)

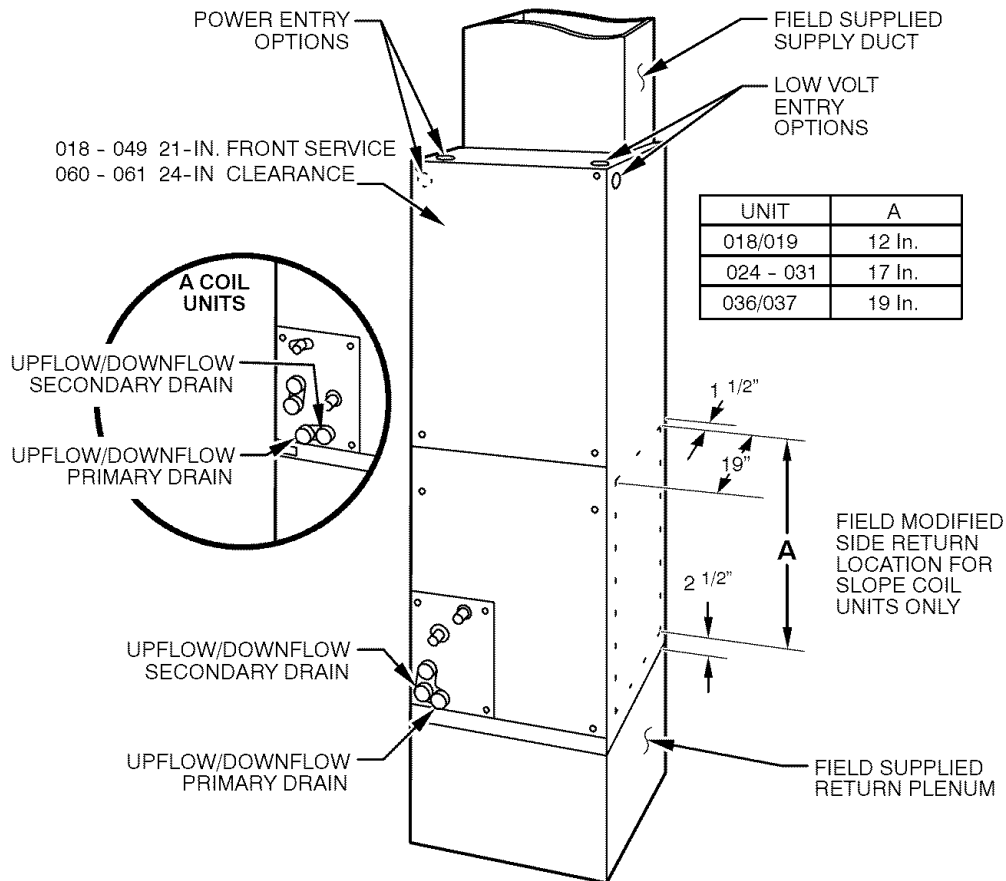

Fig. 1 - Slope Coil Unit in Upflow Application

PF1MNC

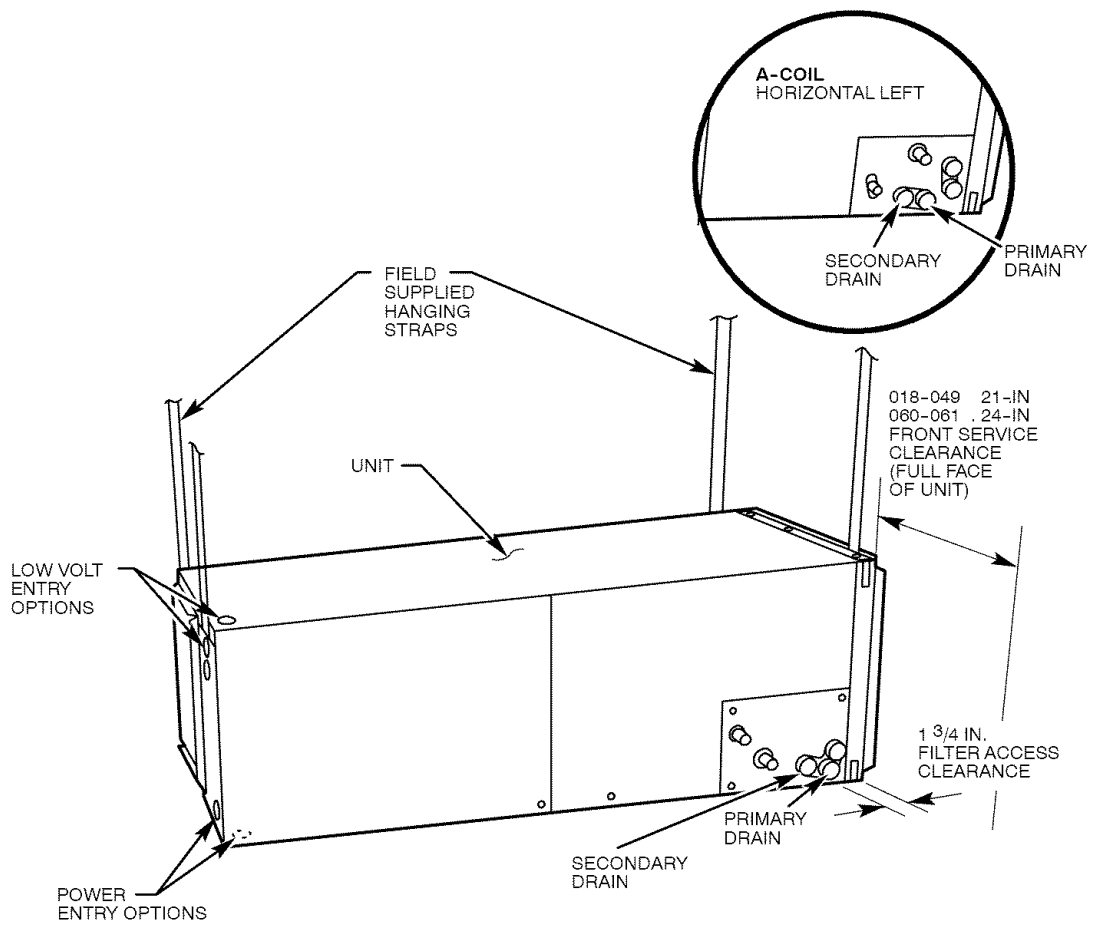

Fig. 2 - Slope Coil Unit in Horizontal Left Application

A05185

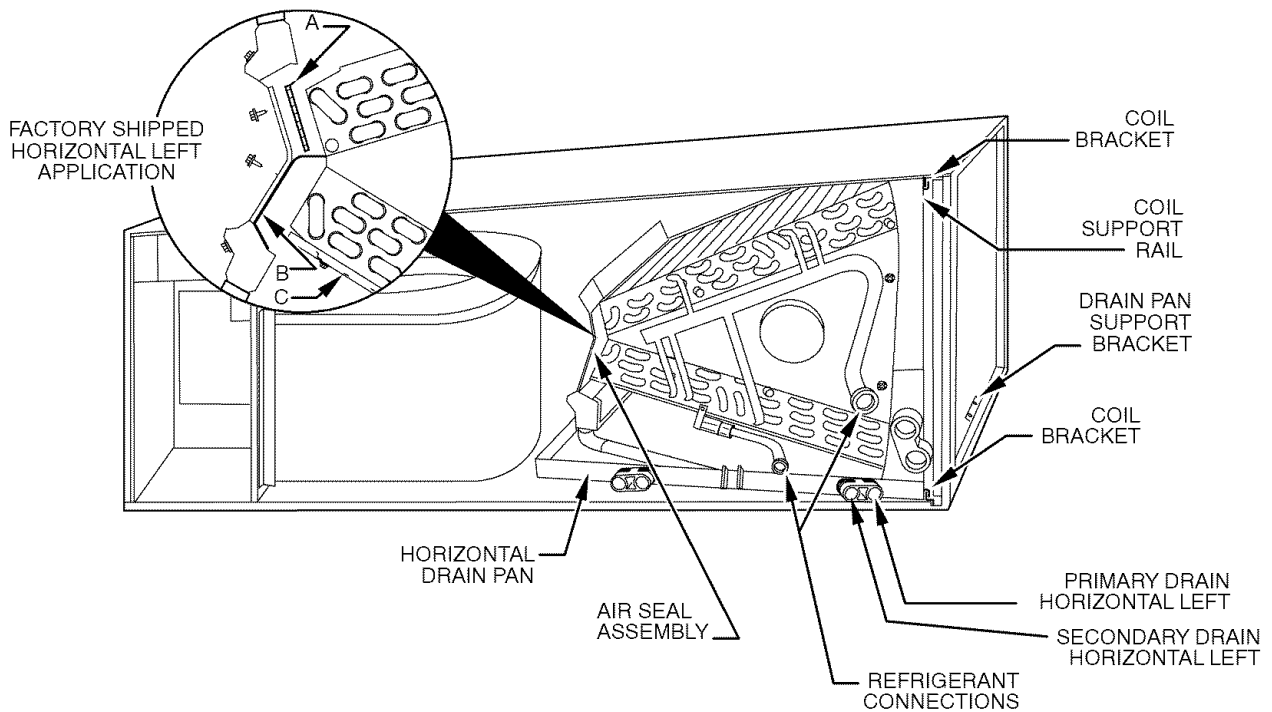
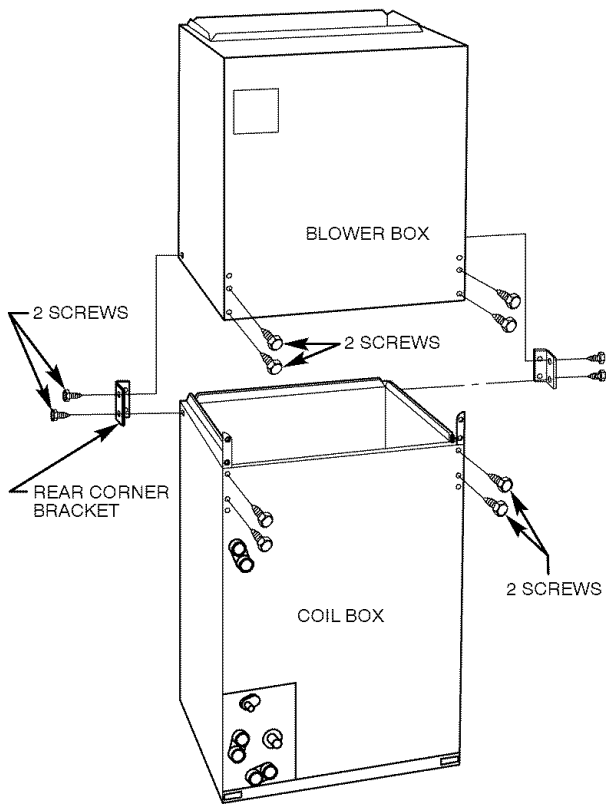

Fig. 3 - A-Coil in Horizontal Left Application (Factory Ready)

A00072



A95293

Fig. 4 - Removal of Brackets on Modular Units

Horizontal Right Conversion of Units With Slope Coils

NOTE: Gasket kit number KFAHD0101SLP is required for horizontal slope coil conversion to maintain low air leak/low sweat performance.

1. Remove blower and coil access panel and fitting panel. (See Fig. 5.)
2. Remove coil mounting screw securing coil assembly to right side casing flange.
3. Remove coil assembly.
4. Lay fan coil unit on its right side and reinstall coil assembly with condensate pan down. (See Fig. 5.)
5. Attach coil to casing flange using coil mounting screw previously removed.
6. Make sure the pan cap in the fitting door is properly seated on the fitting door to retain the low air leak rating of the unit.
7. Add gaskets from kit KFAHD per kit instructions.
8. Align holes with tubing connections and condensate pan connections, and reinstall access panels and fitting panel.

Make sure liquid and suction tube grommets are in place to prevent air leaks and cabinet sweating. Install after brazing.

Horizontal Right Conversion of Units With A-Coils

1. Remove blower and coil access panels. (See Fig. 6.)
2. Remove metal clip securing fitting panel to condensate pan. Remove fitting panel.
3. Remove 2 snap-in clips securing A-coil in unit.
4. Slide coil and pan assembly out of unit.

5. Remove horizontal drain pan support bracket from coil support rail on left side of unit and reinstall on coil support rail on right side of unit.
6. Convert air seal assembly for horizontal right application.
 - a. Remove air seal assembly from coil by removing 4 screws. (See Fig. 6.)
 - b. Remove air splitter (B) from coil seal assembly by removing 3 screws. (See Fig. 3-factory shipped inset.)
 - c. Remove filter plate (A) and install air splitter (B) in place of filter plate.
 - d. Install filter plate (A) as shown in horizontal right application.
 - e. Remove condensate troughs (C) and install on opposite tube sheets.
 - f. Install hose onto plastic spout.
7. Install horizontal pan on right side of coil assembly.
8. Slide coil assembly into casing. Be sure coil bracket on each corner of vertical pan engages coil support rails.
9. Remove two oval fitting caps from left side of the coil, access panel, and fitting panel.
10. Remove insulation knockouts on right side of coil access panel.
11. Install condensate pan fitting caps from item 10 in the right side of the coil door .
12. Install condensate pan fitting caps (from item 10) in the right side of the coil door making sure that the cap snaps and seats cleanly on the back side of the coil door. Make sure no insulation interferes with seating of the cap.
13. Reinstall access and fitting panels, aligning holes with tubing connections and condensate pan connections. Be sure to reinstall metal clip between fitting panel and vertical condensate pan.

Make sure liquid and suction tube grommets are in place to prevent air leaks and cabinet sweating.

Step 3—Air Ducts

Connect supply-air duct over the outside of 3/4-in. flanges provided on supply-air opening. Secure duct to flange, using proper fasteners for type of duct used, and seal duct-to-unit joint. If return-air flanges are required, install factory-authorized accessory kit.

Use flexible connectors between ductwork and unit to prevent transmission of vibration. When electric heater is installed, use heat-resistant material for flexible connector between ductwork and unit at discharge connection. Ductwork passing through unconditioned space must be insulated and covered with vapor barrier.

Units equipped with 20-30kW electric heaters require a 1-in. clearance to combustible materials for the first 36 in. of supply duct.

Ductwork Acoustical Treatment

Metal duct systems that do not have a 90° elbow and 10 ft of main duct to first branch takeoff may require internal acoustical insulation lining. As an alternative, fibrous ductwork may be used if constructed and installed in accordance with the latest edition of SMACNA construction standard on fibrous glass ducts. Both acoustical lining and fibrous ductwork shall comply with National Fire Protection Association as tested by UL Standard 181 for Class 1 air ducts.

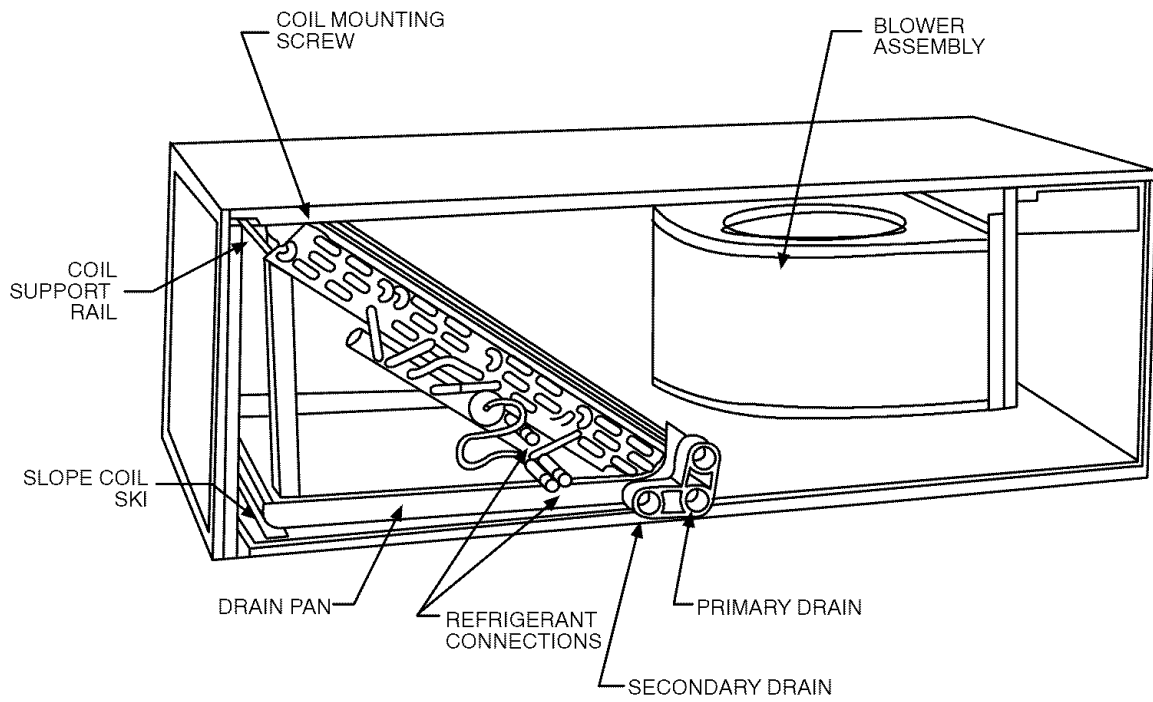

PF1MNC

Fig. 5 - Conversion for Horizontal Right Applications Using a Slope Coil

A03001

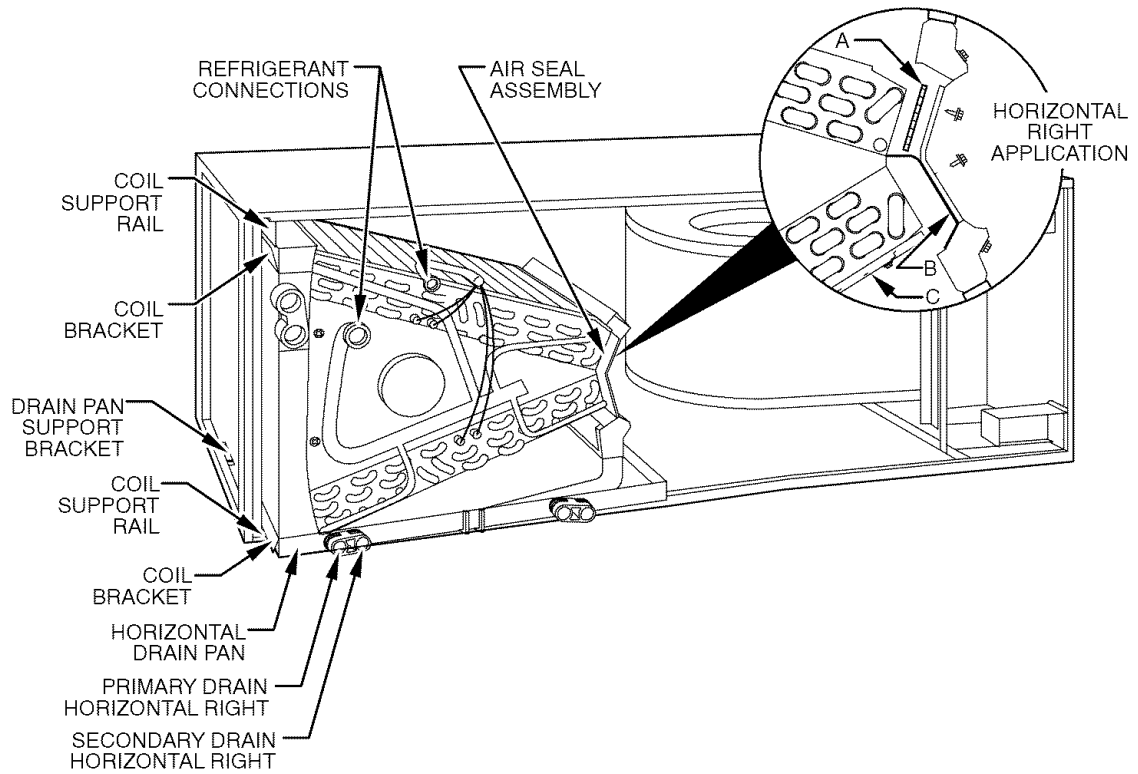

Fig. 6 - Conversion for Horizontal Right Applications Using A-Coil

A00071

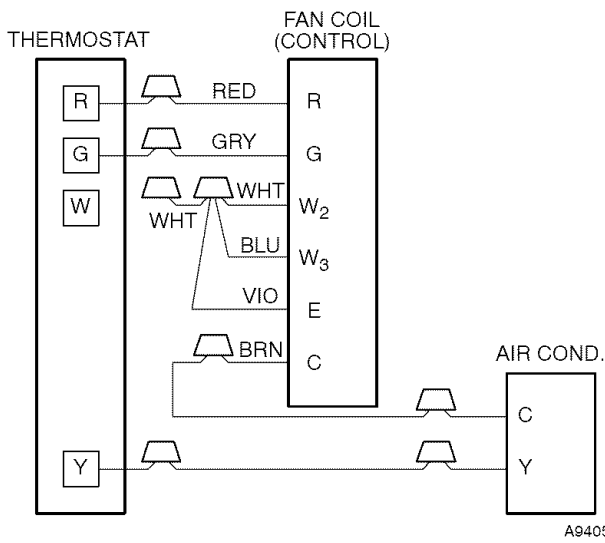

Fig. 9 - Wiring Layout Air Conditioning Unit (Cooling Only)

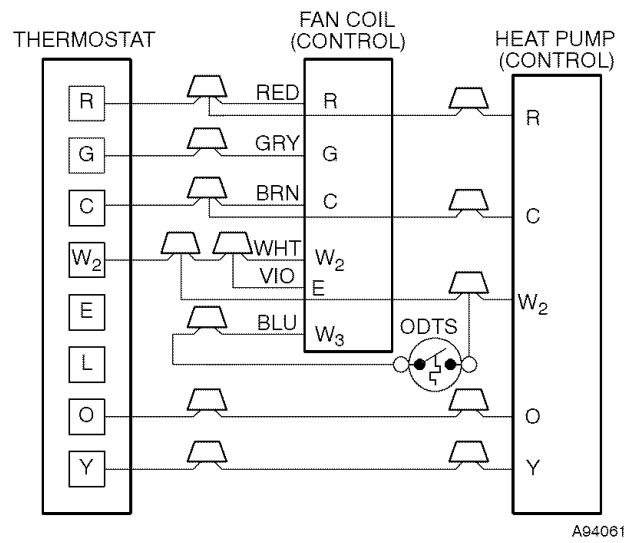

Fig. 12 - Wiring Layout Heat Pump Unit (Cooling & 2-Stage Heat with 1 Outdoor Thermostat)

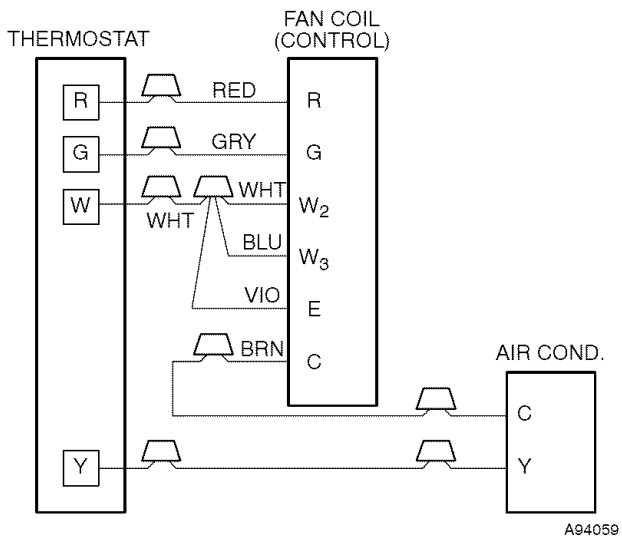

Fig. 10 - Wiring Layout Air Conditioning Unit (Cooling & 1-Stage Heat)

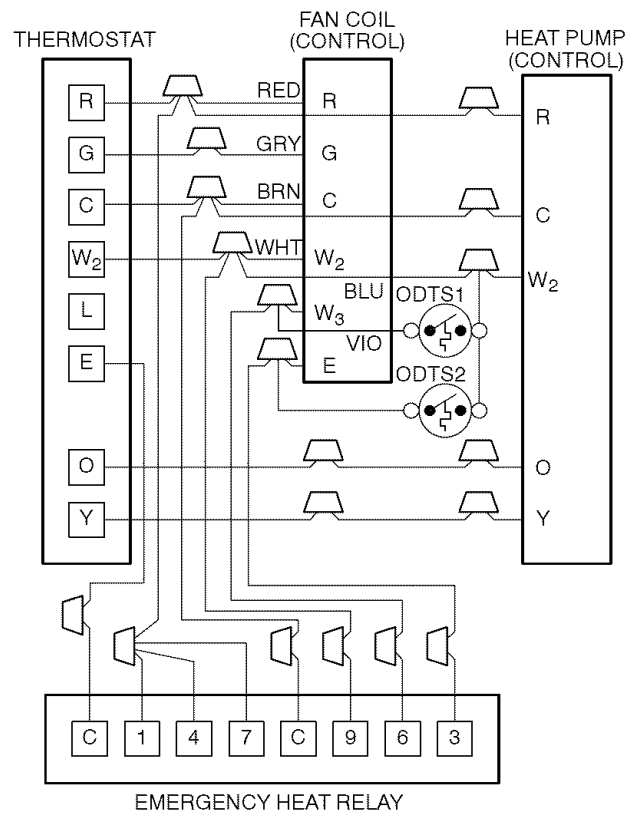

Fig. 13 - Wiring Layout Heat Pump Unit (Cooling & 2-Stage Heat with 2 Outdoor Thermostats)

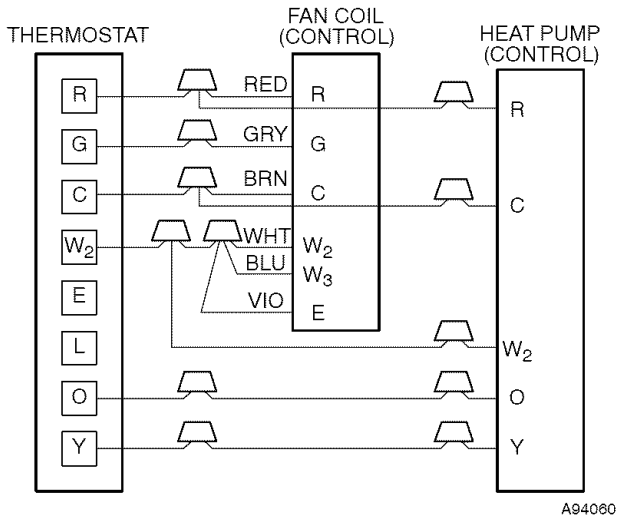
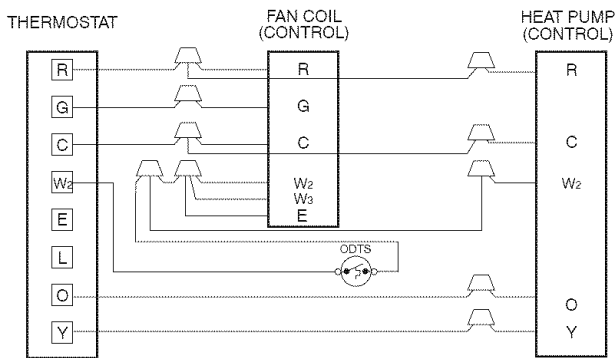

Fig. 11 - Wiring Layout Heat Pump Unit (Cooling & 2-Stage Heat with No Outdoor Thermostat)

PF1MNC



A03088

**Fig. 14 - Wiring Layout Heat Pump Unit
(Cooling and 2-Stage Heat for Manufactured Housing)**

Transformer Information

Transformer is factory-wired for 230v operation. For 208v applications, disconnect the black wire from the 230v terminal on transformer and connect it to the 208v terminal. (See Fig. 15.)

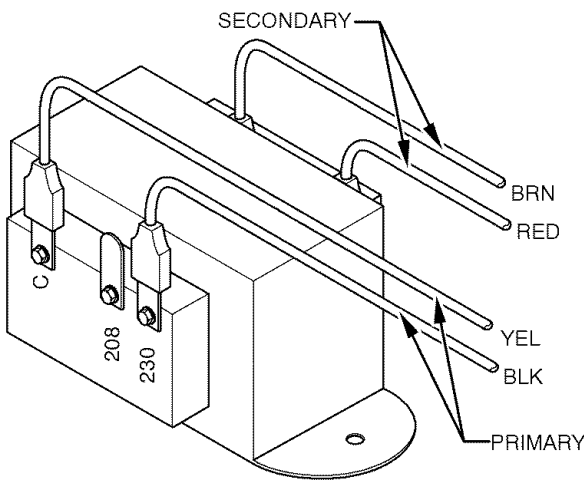

A05182

Fig. 15 - Transformer Connections

Heater Staging

The controls are factory circuited for single-stage operation. For 2-stage operation, use outdoor thermostat kit Part No. KHAOT0301FST, and for 3-stage use both kits Part No. KHAOT0201SEC and KHAOT0301FST. When 2 stages are desired, cut W3 at the W2 wire nut, strip and reconnect per the thermostat kit instruction. (See Fig. 12.) When 3 stages are desired, cut the W2 wire nut off and discard. Strip W2, W3, and E and reconnect per thermostat kit instructions (see Fig. 14).

CAUTION

PROPERTY DAMAGE HAZARD

Failure to follow this caution may result in product or property damage.

If W2, W3, and E on any 3 stage heater (18, 20, 24, or 30kW), are individually connected as with outdoor thermostats or any other situation, emergency heat relay must be used. This relay is in kit Part No. KHAOT0201SEC and is normally used with kit Part No. KHAOT0301FST for 2 outdoor thermostat system.

NOTE: When 3 stages are used or any time the E terminal is not tied to W2, the emergency heat relay, part of outdoor kit Part No. KHAOT0201SEC, must be used.

C. Manufactured Housing

In manufactured housing applications, the Code of Federal Regulations, Title 24, Chapter XX, Part 3280.714 requires that supplemental electric heat be locked out at outdoor temperatures above 40° F except for a heat pump defrost cycle. Refer to Fig. 14 for typical low voltage wiring with outdoor thermostat.

D. Ground Connections

WARNING

ELECTRICAL SHOCK HAZARD

Failure to follow this warning could result in personal injury or death.

According to NEC, ANSI/NFPA 70, and local codes, the cabinet must have an uninterrupted or unbroken ground to minimize personal injury if an electrical fault should occur. The ground may consist of electrical wire or metal conduit when installed in accordance with existing electrical codes. If conduit connection uses reducing washers, a separate ground wire must be used. (See Ground/Conduit Note below.)

NOTE: Use UL-listed conduit and conduit connector for connecting supply wire(s) to unit to obtain proper grounding. Grounding may also be accomplished by using grounding lugs provided in control box.

E. Minimum CFM and Motor Speed Selection

Units with or without electric heaters require a minimum CFM. Refer to the unit wiring label to ensure that the fan speed selected is not lower than the minimum fan speed indicated. Fan speed selection for sizes 018, 024, 030, 036, 042, 048 and 060 is done at the fan relay printed-circuit board. To change motor speeds, disconnect fan lead used on relay terminal (SPT) and replace with motor speed tap desired. (See Fig. 16.) Save insulating cap and place on motor lead removed from relay.

NOTE: In low static applications, lower motor speed tap should be used to reduce possibility of water being blown off coil. Sizes 018 through 036 have 2 motor speed taps. Sizes 042, 048 and 060 have 3 motor speed taps. Low speed (red) is designed for mismatched outdoor unit applications. Medium speed (blue) is designed for straight matched operations. High speed (black) is used with high external static duct systems of straight matched systems.

The fan speed selection on the 019, 025, 031, 037, 043, 049, and 061 models is done at the motor. To change motor speeds, disconnect fan lead from terminal 2 and move to desired speed tap; low speed (one), medium (two), and high (three).

Step 5—Refrigerant Tubing

Use accessory tubing package or field-supplied tubing of refrigerant grade. Suction tube must be insulated. Do not use damaged, dirty, or contaminated tubing because it may plug refrigerant flow-control device. ALWAYS evacuate the coil and field-supplied tubing to 500 microns before opening outdoor unit service valves.

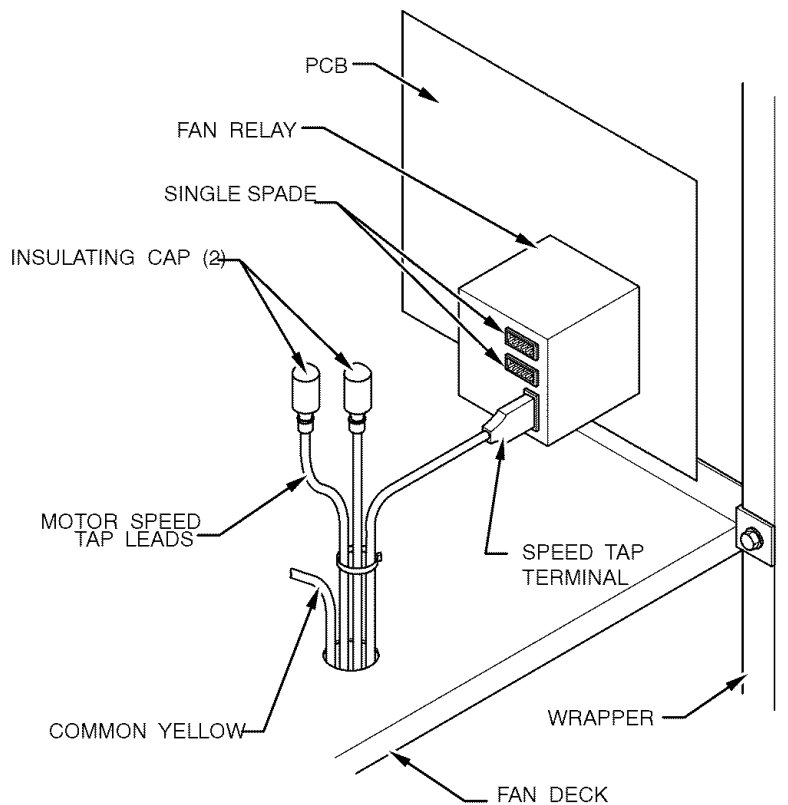

Fig. 16 - Fan Coil Relay and Speed Tap Terminal
For Sizes 018, 024, 030, 036, 042, 048 & 060

A97529

⚠ CAUTION

PRODUCT DAMAGE HAZARD

Failure to follow this caution may result in product or property damage.

A brazing shield **MUST** be used when tubing sets are being brazed to the unit connections to prevent damage to the unit surface and condensate pan fitting caps.

Units have sweat suction and liquid tube connections. Make suction tube connection first.

1. Cut tubing to correct length.
2. Insert tube into sweat connection on unit until it bottoms.
3. Braze connection using silver-bearing or non-silver-bearing brazing materials. Do not use solder (materials which melt below 800°F). Consult local code requirements.

⚠ CAUTION

PRODUCT DAMAGE HAZARD

Failure to follow this caution may result in product or property damage.

Wrap a wet cloth around rear of fitting to prevent damage to TXV and factory-made joints.

Step 6—Refrigerant Flow-Control Device

⚠ CAUTION

PRODUCT OPERATION HAZARD

Failure to follow this caution may result in improper product operation.

If using a TXV in conjunction with a single-phase reciprocating compressor, a compressor start capacitor and relay are required. Consult outdoor unit pre-sale literature for start assist kit part number.

Step 7—Condensate Drains

To connect drains, the cap openings must be removed. Use a knife to start the opening near the tab and, using pliers, pull the tab to remove the disk. Clean the edge of the opening, if necessary, and install the condensate line. Finally, caulk around the lines where they exit the fitting to retain the low leak rating of the unit.

⚠ CAUTION

UNIT OR PROPERTY DAMAGE HAZARD

Failure to follow this caution may result in product or property damage.

The conversion of the fan coil to downflow requires special procedures for the condensate drains on both A-coil and slope units. The vertical drains have an overflow hole between the primary and secondary drain holes. This hole is plugged for all applications except downflow, but must be used for downflow. During the conversion process, remove the plastic cap covering the vertical drains only and discard. Remove the plug from the overflow hole and discard. At completion of the downflow installation, caulk around the vertical pan fitting to door joint to retain the low air leak performance of the unit.

Units are equipped with primary and secondary 3/4-in. FPT drain connections. For proper condensate line installations see Fig. 1, 2, 3, 5, and 6. To prevent property damage and achieve optimum drainage performance, BOTH primary and secondary drain lines should be installed and include properly-sized condensate traps (see Fig. 17 and 19). Factory-approved condensate traps are available. It is recommended that PVC fittings be used on the plastic condensate pan; finger-tighten plus 1-1/2 turns. Do not over-tighten. Use pipe dope.

⚠ CAUTION

PROPERTY DAMAGE HAZARD

Failure to follow this caution may result in product or property damage.

Shallow running traps are inadequate and DO NOT allow proper condensate drainage. (See Fig. 18.)

NOTE: When connecting condensate drain lines, avoid blocking filter access panel, thus preventing filter removal. After connection, prime both primary and secondary condensate traps.

NOTE: If unit is located in or above a living space where damage may result from condensate overflow, a field-supplied, external condensate pan should be installed underneath the entire unit, and a secondary condensate line (with appropriate trap) should be run from the unit into the pan. Any condensate in this external condensate pan should be drained to a noticeable place. As an alternative to using an external condensate pan, some localities may allow the use of a separate 3/4-in. condensate line (with appropriate trap) to a place where the condensate will be noticeable. The owner of the structure must be informed that when condensate flows from the secondary drain or external condensate pan, the unit requires servicing or water damage will occur.

Install traps in the condensate lines as close to the coil as possible. (See Fig. 19.) Make sure that the outlet of each trap is below its connection to the condensate pan to prevent condensate from overflowing the drain pan. Prime all traps, test for leaks, and insulate traps if located above a living area.

Condensate drain lines should be pitched downward at a minimum slope of 1 in. for every 10 ft of length.

Consult local codes for additional restrictions or precautions.

Step 8—Accessories

A. Electric Heaters

See unit rating plate for factory-approved electric heater kits. Follow installation instructions provided with kit.

B. Electronic Air Cleaner

The Electronic Air Cleaner may be connected to fan coil as shown in Fig. 20. This method requires a field-supplied transformer. See Electronic Air Cleaner literature for kit requirements.

C. Humidifier

Connect humidifier and humidistat to fan coil unit as shown in Fig. 21 and 22. The cooling lockout relay is optional. (See Fig. 21.)

Step 9—Sequence of Operation

A. Continuous Fan

Thermostat closes R to G. G energizes fan relay on PCB which completes circuit to indoor blower motor. When G is de-energized, there is a 90-sec delay before relay opens.

B. Cooling Mode

Thermostat energizes R to G, R to Y, and R to O (heat pump only). G energizes fan relay on PCB which completes circuit to indoor blower motor. When G is de-energized, there is a 90-sec delay before fan relay opens.

C. Heat Pump Heating Mode

Thermostat energizes R to G and R to Y. G energizes fan relay on PCB which completes circuit to indoor blower motor. When G is de-energized, there is a 90-sec delay before fan relay opens.

D. Heat Pump Heating with Auxiliary Electric Heat

Thermostat energizes R to G, R to Y, and R to W. G energizes fan relay on PCB which completes circuit to indoor blower motor. W energizes electric heat relay(s) which completes circuit to heater element(s). When W is de-energized, electric heat relay(s) open, turning off heater elements. When G is de-energized there is a 90-sec delay before fan relay opens.

E. Electric Heat or Emergency Heat Mode

Thermostat closes R to W. W energizes electric heat relay(s) which completes circuit to heater element(s). Blower motor is energized through normally closed contacts on fan relay. When W is de-energized, electric heat relay(s) opens.

START-UP PROCEDURES

Refer to outdoor unit Installation Instructions for system start-up instructions and refrigerant charging method details.

⚠ CAUTION

UNIT COMPONENT HAZARD

Failure to follow this caution may result in product damage.

Never operate unit without a filter. Damage to blower motor or coil may result. Factory authorized filter kits must be used when locating the filter inside the unit. For those applications where access to an internal filter is impractical, a field-supplied filter must be installed in the return duct system.

CARE AND MAINTENANCE

To continue high performance and minimize possible equipment failure, it is essential that periodic maintenance be performed on this equipment. Consult your local dealer as to the proper frequency of maintenance contract.

The ability to properly perform maintenance on this equipment requires certain mechanical skills and tools. If you do not possess these, contact your dealer for maintenance. The only consumer service recommended or required is filter replacement or cleaning on a monthly basis.

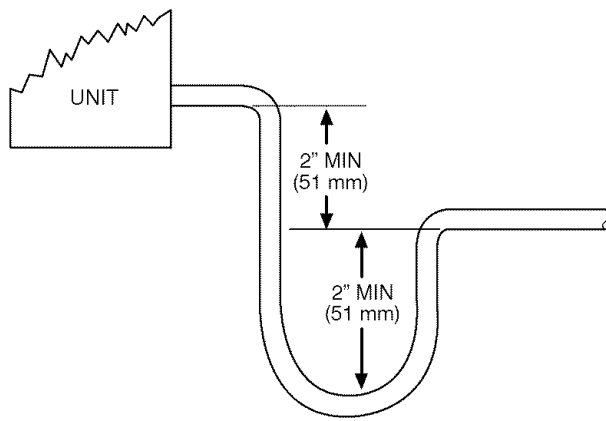
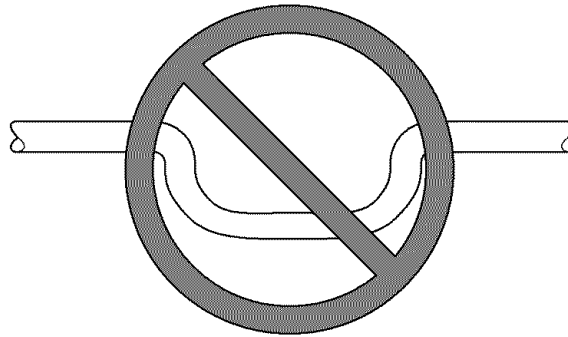

Fig. 17 - Recommended Condensate Trap

A03002

PF1MNC



DO NOT USE SHALLOW RUNNING TRAPS!

Fig. 18 - Insufficient Condensate Trap

A03013

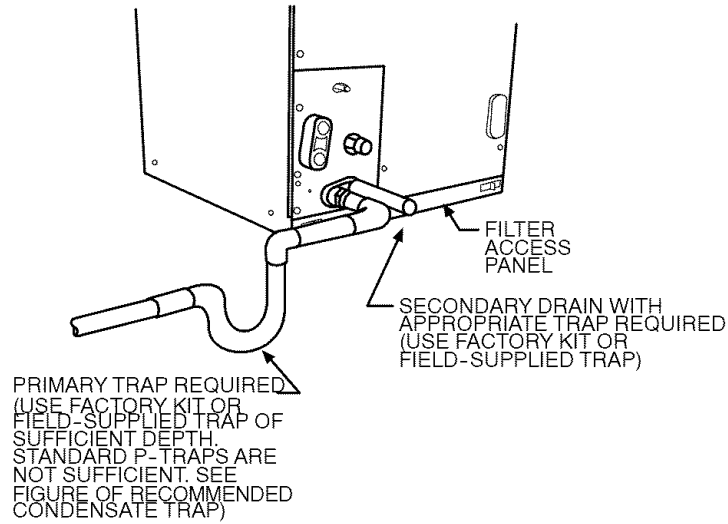

Fig. 19 - Condensate Trap and Unit

A03003

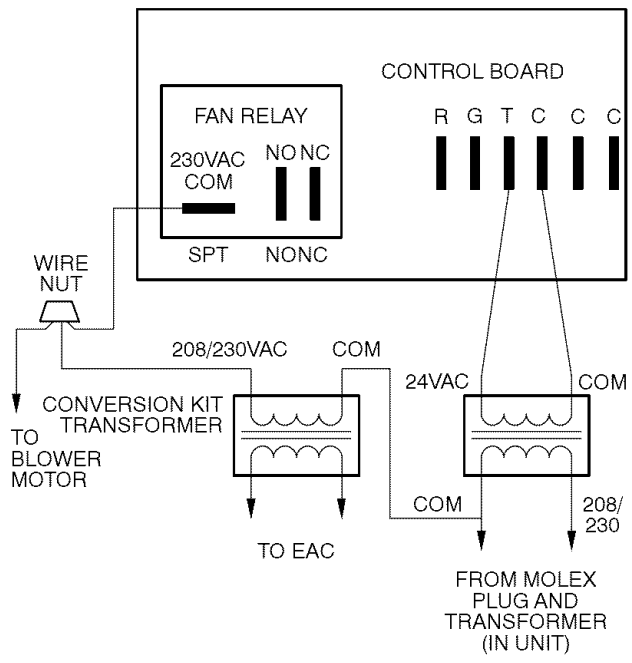

Fig. 20 - Wiring Layout of Electronic Air Cleaner to Fan Coil Sizes 018, 024, 030, 036, 042, 048 & 060

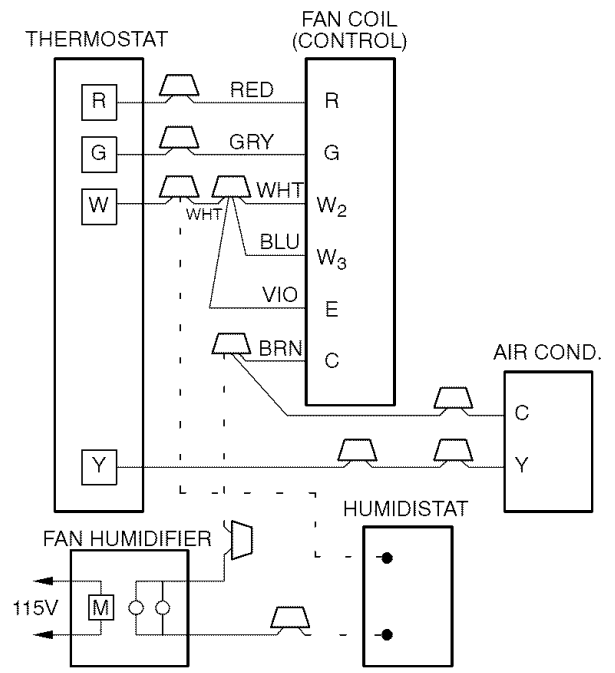

Fig. 22 - Wiring Layout of Humidifier to Fan Coil With Electric Heat

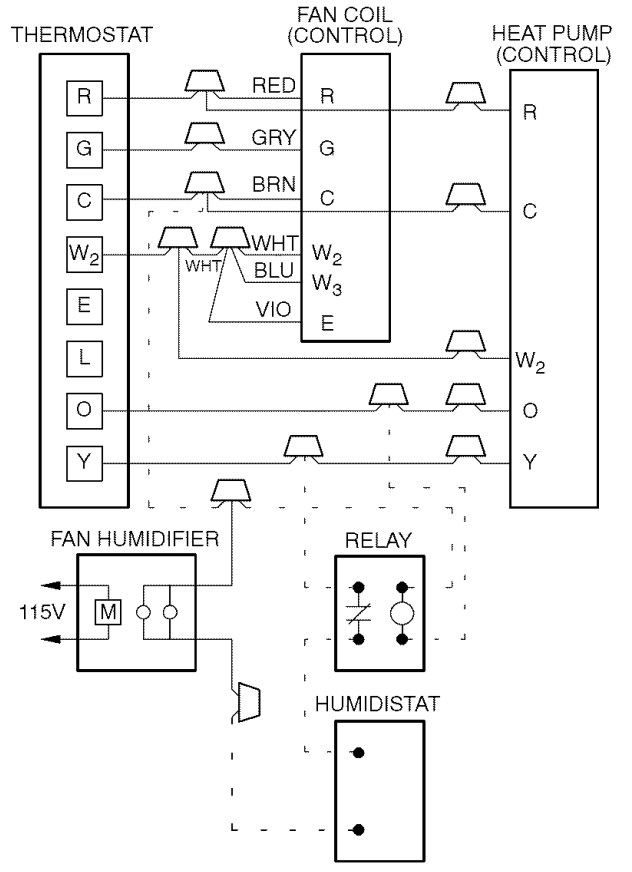

Fig. 21 - Wiring Layout of Humidifier to Heat Pump