

INSTALLATION INSTRUCTIONS

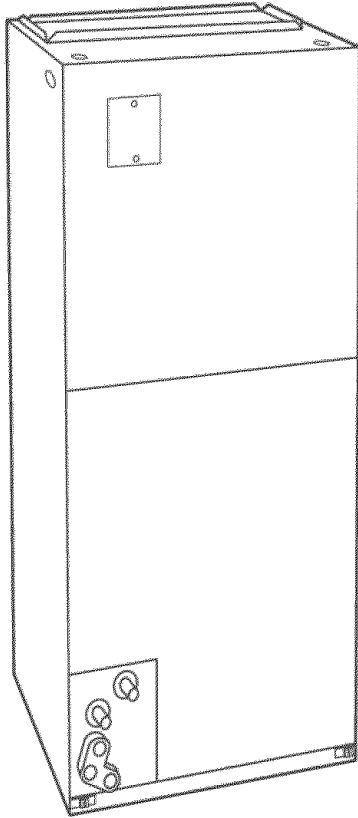

Models

EBP

EBX

Use **ONLY** factory listed electric heaters.

Fan Coils

General Information / Installation	2
Upflow Installations	3
Downflow Installations	3
Horizontal Installations	3
Ductwork Connections	4
Electrical Connections	5
Diagrams	6
Transformer Information	7
Refrigerant Tubing	8
Refrigerant Flow Control	8
Condensate Drains	9
Condensate Drain Diagrams	10
Start-Up Procedures	11

Safety Labeling and Signal Words

Danger, Warning and Caution

The signal words **DANGER**, **WARNING** and **CAUTION** are used to identify levels of hazard seriousness. The signal word **DANGER** is only used on product labels to signify an immediate hazard. The signal words **WARNING** and **CAUTION** will be used on product labels and throughout this manual and other manuals that may apply to the product.

DANGER - Immediate hazards which **WILL** result in severe personal injury or death.

WARNING - Hazards or unsafe practices which **COULD** result in severe personal injury or death.

CAUTION - Hazards or unsafe practices which **COULD** result in minor personal injury or product or property damage.

Signal Words in Manuals

The signal word **WARNING** is used throughout this manual in the following manner:

WARNING

The signal word **CAUTION** is used throughout this manual in the following manner:

CAUTION

Product Labeling

Signal words are used in combination with colors and/or pictures on product labels.

Figure 1

Clearances

WARNING

Fire Hazard

When heaters are installed maintain clearances from combustible materials as specified on unit rating plate. Do not use plastic lined or combustible flexible ducting within 36 inches of the supply end of the air handler.

Failure to do so can result in fire, property damage, personal injury or death.

CLEARANCES

NO HEATERS

All Sides 0"
 From Supply Duct 0"
 Recommended Service From Front 20"
 (Service for blower, filter if installed)

WITH HEATERS

All Sides 0"
 From First Three Feet of Supply Duct to Combustibles 1"
 From Duct after Three Feet 0"
 Recommended Service From Front 20"

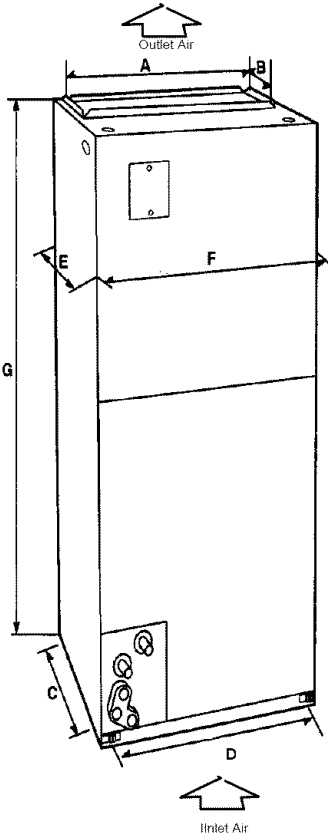

EBP							
Unit Sizes	A	B	C	D	E	F	G
1800	12-7/16"	11"	19-13/16"	12-5/16"	22-1/16"	14-5/16"	42-11/16"
2400	12-7/16"	11"	19-13/16"	12-5/16"	22-1/16"	14-5/16"	42-11/16"
3000	15-3/4"	11"	19-13/16"	15-5/8"	22-1/16"	17-5/8"	47-11/16"
3600	15-3/4"	11"	19-13/16"	15-5/8"	22-1/16"	17-5/8"	49-5/8"
4200	19-1/4"	11"	19-13/16"	19-1/8"	22-1/16"	21-1/8"	53-7/16"
4800	19-1/4"	11"	19-13/16"	19-1/8"	22-1/16"	21-1/8"	49-5/8"
6000	19-1/4"	11"	19-13/16"	19-1/8"	22-1/16"	21-1/8"	53-7/16"
EBX							
Unit Sizes	A	B	C	D	E	F	G
1800	15-3/4"	11"	19-13/16"	15-5/8"	22-1/16"	17-5/8"	47-11/16"
2400	15-3/4"	11"	19-13/16"	15-5/8"	22-1/16"	17-5/8"	47-11/16"
3600	19-1/4"	11"	19-13/16"	19-1/8"	22-1/16"	21-1/8"	53-7/16"
4800	19-1/4"	11"	19-13/16"	19-1/8"	22-1/16"	21-1/8"	53-7/16"
6000	22-3/4"	11"	19-13/16"	22-11/16"	22-1/16"	24-11/16"	59-3/16"

General Information

WARNING

Installation or repairs made by unqualified persons can result in hazards to you and others. Installation MUST conform with local building codes and with the National Electrical Code NFPA70 current edition.

The information contained in this manual is intended for use by a qualified service technician familiar with safety procedures and equipped with the proper tools and test instruments.

Failure to carefully read and follow all instructions in this manual can result in equipment malfunction, property damage, personal injury and/or death.

The blower cabinet may be used for cooling or heat pump operation with or without electric heat. Installations without electric heat, require a No Heat Kit. The cabinet can be installed in an upflow or horizontal position

(Figure 2, 3). Horizontal installations require a horizontal kit. Some models are shipped with the horizontal kit already installed. EBP units are not shipped with air filters installed. Filter must be field installed. Washable filters are available as an accessory.

Location

Select the best position which suits the installation site conditions. The location should provide adequate structural support, space in the front of the unit for service access, clearance for return air and supply duct connections, space for refrigerant piping connections and condensate drain line connections. If heaters are being installed make sure adequate clearance is maintained from supply ductwork, See Clearances and Warning in Figure 1.

NOTE: Internal filter can be accessed from separate filter door. If the filter can NOT be easily accessed, a remote filter is recommended. Refer to ACCA Manual D for remote filter sizing.

If the unit is located in an area of high humidity, nuisance sweating of casing may occur. On these installations a wrap of 2" fiberglass insulation with a vapor barrier is recommended.

INTRODUCTION

Models EBP and EBX are designed for flexibility and can be used for upflow, horizontal, or downflow (kit required) applications. These units are available for systems of 24,000 through 60,000 Btuh nominal cooling capacity. The EBP Series is also available for 18,000 Btuh nominal cooling capacity. Factory authorized electric heater packages are available in sizes 5 through 30kw. See Product Specification Literature for available accessory kits.

HEATER PACKAGES

A factory approved, field installed UL listed heater package is available from your equipment supplier. See unit rating plate for a list of factory approved heaters. Heaters that are not factory approved could cause damage which would not be covered under the equipment warranty.

INSTALLATION

PROCEDURE 1-MOUNT UNIT

Unit can stand or lie on floor, or hang from ceiling or wall. Allow space for wiring, piping, and servicing unit.

A. Upflow Installation

If return air is to be ducted through a floor, set unit on floor over opening and use 1/8- to 1/4-in. thick fireproof resilient gasket between duct, unit, and floor.

Side return is a field option on slope coil models. Cut opening per dimensions. (See Fig. 2) A field-supplied bottom closure is required.

B. Downflow Installation

In this application, field conversion of the evaporator coil is required using accessory downflow kit along with an accessory base kit. See installation instructions packaged with accessory kit. See Product Specification for kit part numbers.

C. Horizontal Installation

CAUTION

A field fabricated auxiliary drain pan, with a separate drain is REQUIRED for all installations over a finished living space or in any area that may be damaged by overflow from a restricted main drain pan. In some localities, local codes require an auxiliary drain pan for ANY horizontal installation.

Units must not be installed with access panels facing up or down. With the exception of EBP****A models, all units are factory built for horizontal left installation which can be field convertible. (See Fig. 3 and 7). When suspending unit from ceiling, dimples in casing indicate suitable location of screws for mounting metal support straps. (See Fig. 3).

Figure 2 Slope Coil Unit In Upflow Application

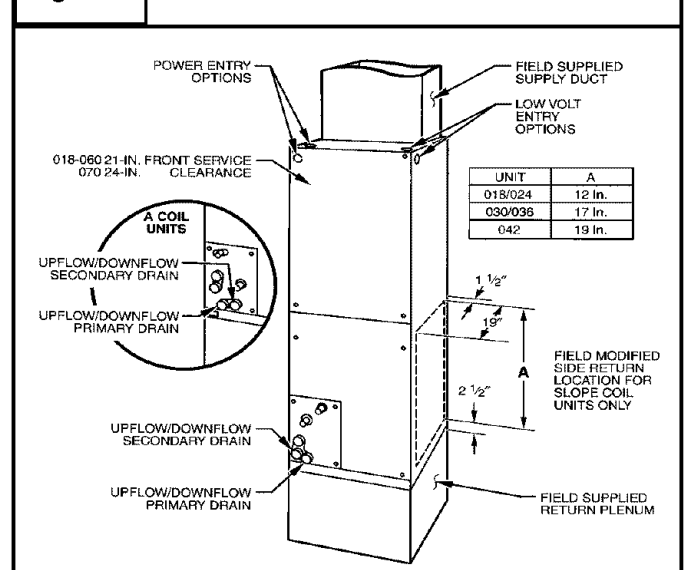

CAUTION: For optimum condensate drainage performance in horizontal installations, unit should be leveled along its length and width.

NOTE: Modular units can be disassembled and components moved separately to installation area for reassembly. This process accommodates small scuttle holes and limiting entrances to installation sites. (See Fig. 4).

HORIZONTAL RIGHT CONVERSION OF UNITS WITH SLOPE COILS

1. Remove blower and coil access panel and fitting panel. (See Fig. 5.)
2. Remove coil mounting screw securing coil assembly to right side casing flange.
3. Remove coil assembly.
4. Lay fan coil unit on its right side and reinstall coil assembly with condensate pan down. (See Fig. 5.)
5. Attach coil to casing flange using coil mounting screw previously removed.
6. Align holes with tubing connections and condensate pan connections, and reinstall access panels and fitting panel.
Make sure liquid and suction tube grommets are in place to prevent air leaks and cabinet sweating. Install after brazing.

HORIZONTAL RIGHT CONVERSION OF UNITS WITH A-COILS

1. Remove blower and coil access panel and fitting panel.
2. Remove coil mounting screw securing coil assembly to right side casing flange.
3. Remove coil assembly.
4. Lay fan coil unit on its right side and reinstall coil assembly with condensate pan down. (See Fig. 6).
5. Remove horizontal drain pan support bracket from coil support rail on left side of unit and reinstall on coil support rail on right side of unit.
6. Convert air-seal assembly for horizontal right. (See Fig. 6).
 - A. Remove air-seal assembly from coil by removing 4 screws.
 - B. Remove coil drip flanges from A-coil and reinstall on right side of coil (same side as horizontal drain pan).
 - C. Remove filler plate (A) and install air splitter (B) in place of filler plate.
 - D. Install filler plate (A) as shown in horizontal right application.
 - E. Remove condensate troughs (C) and install on opposite tube sheets.

- F. Install hose onto plastic spout.
- 7. Install horizontal pan on right side of coil assembly.
- 8. Slide coil assembly into casing. Be sure coil bracket on each corner of vertical pan engages coil support rails.
- 9. Reinstall 2 snap-in clips to correctly position and secure coil assembly in unit. Be sure clip with large offsets is used on right side of unit to secure horizontal pan.
- 10. Remove 2 oval coil access panel plugs and reinstall into holes on left side of coil access panel and fitting panel.
- 11. Remove insulation knockouts on right side of coil access panel
- 12. Reinstall access fitting panels, aligning holes with tubing connections and condensate pan connections. Be sure to reinstall metal clip between fitting panel and vertical condensate pan.

Make sure liquid and suction tube grommets are in place to prevent air leaks and cabinet sweating.

D. Manufactured and Mobile Home Housing Applications

- 1. Fan coil unit must be secured to the structure using field-supplied hardware.
- 2. Allow a minimum of 24" clearance from access panels.
- 3. Recommended method of securing for typical applications
 - a. If fan coil is away from wall, attach pipe strap to top of fan coil using No. 10 self tapping screws. Angle strap down and away from back of fan coil, remove all slack, and fasten to wall stud of

structure using 5/16-in. lag screws. Typically both sides of fan coil.

- b. If fan coil is against wall, secure fan coil to wall stud using 1/8-in. thick right-angle brackets. Attach brackets to fan coil using No. 10 self tapping screws and to wall stud using 5/16-in. lag screws. (See Fig. 9).

PROCEDURE 2-AIR DUCTS

Connect supply-air duct over the outside of 3/4-in. flanges provided on supply-air opening. Secure duct to flange, using proper fasteners for type of duct used, and seal duct-to-unit joint. If return-air flanges are required, install factory authorized accessory kit.

Use flexible connectors between ductwork and unit to prevent transmission of vibration. When electric heater is installed, use heat-resistant material for flexible connector between ductwork and unit at discharge connection. Ductwork passing through unconditioned space must be insulated and covered with vapor barrier.

Ductwork Acoustical Treatment

Metal duct systems that do not have a 90 degree elbow and 10 ft. of main duct to first branch takeoff may require internal acoustical insulation lining. As an alternative, fibrous ductwork may be used if constructed and installed in accordance with the latest edition of SMACNA construction standard on fibrous glass ducts. Both acoustical lining and fibrous ductwork shall comply with National Fire Protection Association as tested by UL Standard 181 for Class 1 air ducts.

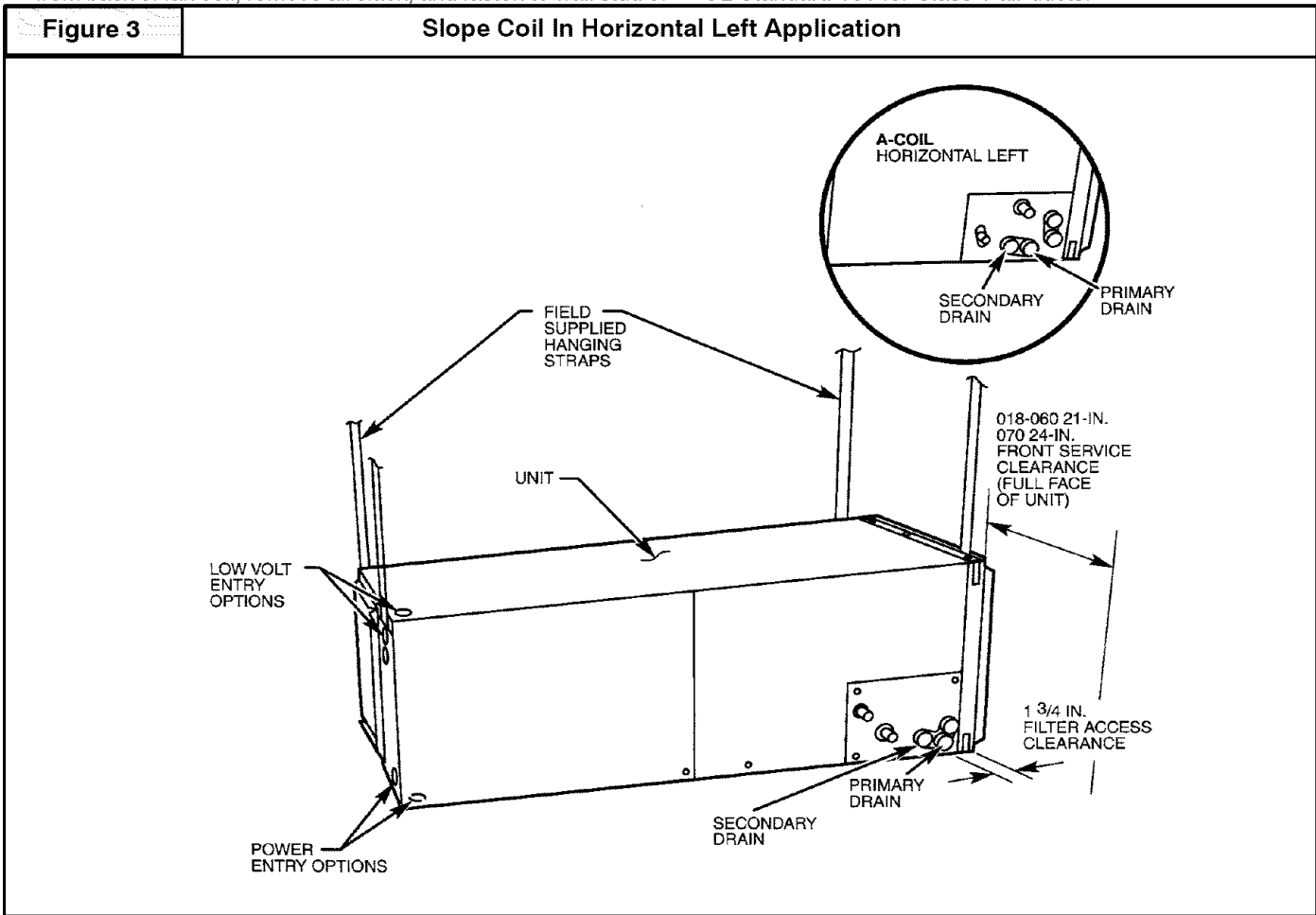
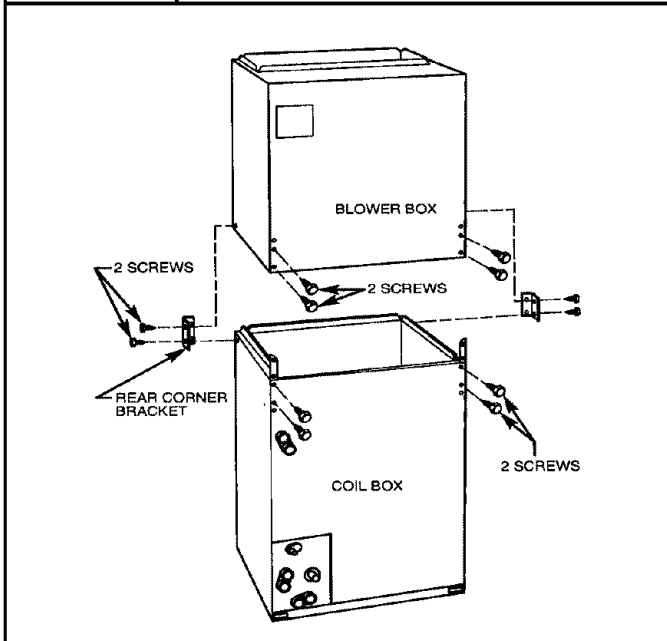

Figure 4 Removal of Brackets on Modular Units



PROCEDURE 3-ELECTRICAL CONNECTIONS

All products from the factory utilize an electronic fan board which has a low voltage circuit protective fuse (5 amp.), fan motor speed tapselection terminal (SPT), and time delay relay (TDR) jumper. To disable the TDR feature, sever the jumper wire JW1. (See Fig. 8.)

A restrictor orifice is located in a fitting at the distributor. The factory installed restrictor orifice is identified on the unit rating plate.

The restrictor orifice may require changing to obtain best performance. Refer to the restrictor charts furnished with the outdoor unit.

CAUTION: If a disconnect switch is to be mounted on unit, select a location where drill or fastener will not contact electrical or refrigerant components.

Before proceeding with electrical connections, make certain that supply voltage, frequency, phase, and ampacity are as specified on the unit rating plate. See unit wiring label for proper field high- and low-voltage wiring. Make all electrical connections in accordance with the NEC and any local codes or ordinances that may apply. Use copper wire only. The unit must have a separate branch electric circuit with a field-supplied disconnect switch located within sight from and readily accessible from the unit.

Figure 5 Conversion for Horizontal Right Applications Using a Slope Coil

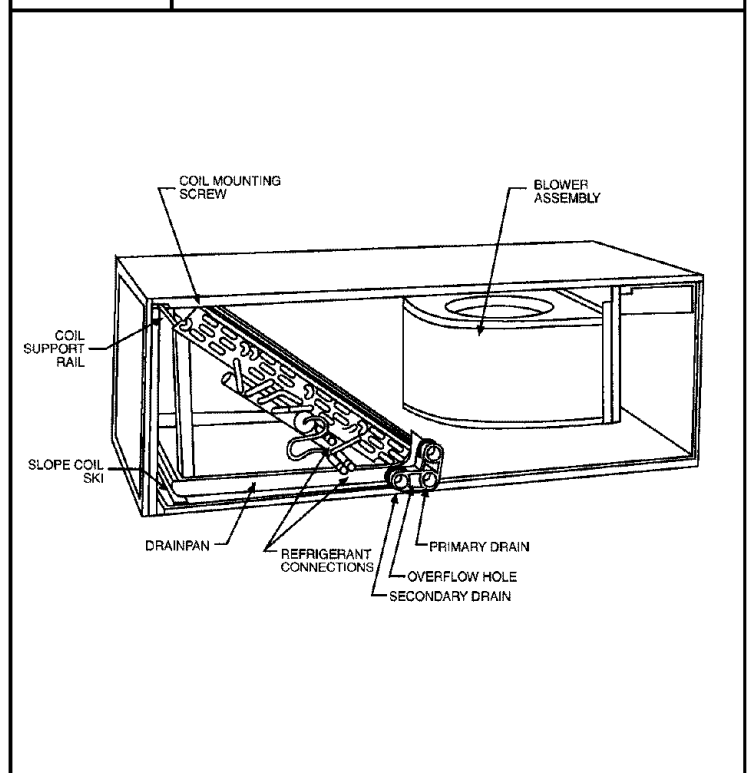

Figure 6 Conversion for Horizontal Right Applications Using A-Coil

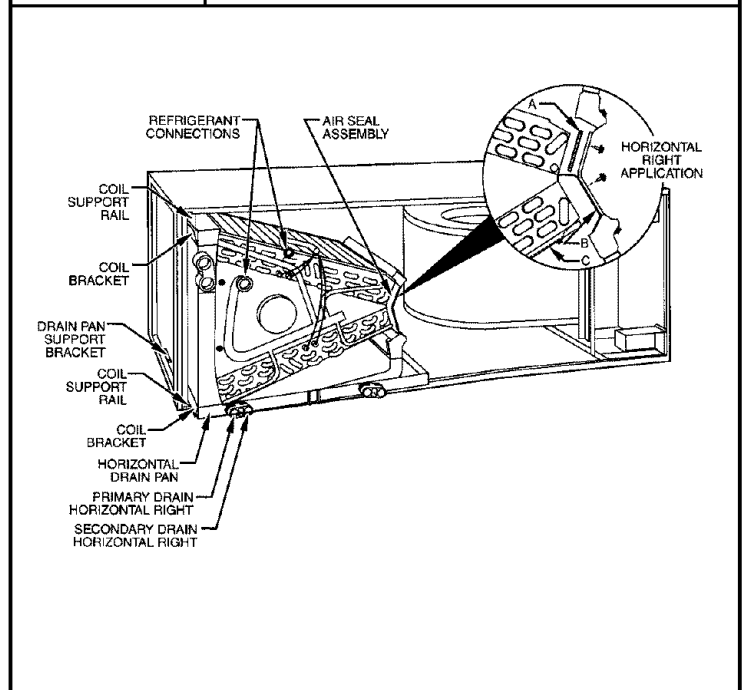

Figure 7 A-Coil in Horizontal Left Application

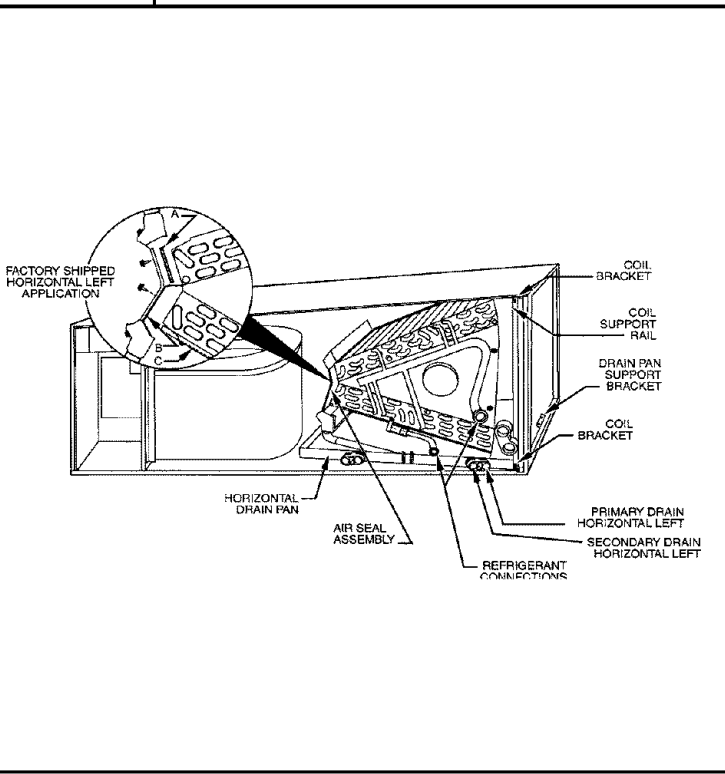

Figure 9 Mobile Home or Manufactured Housing Applications

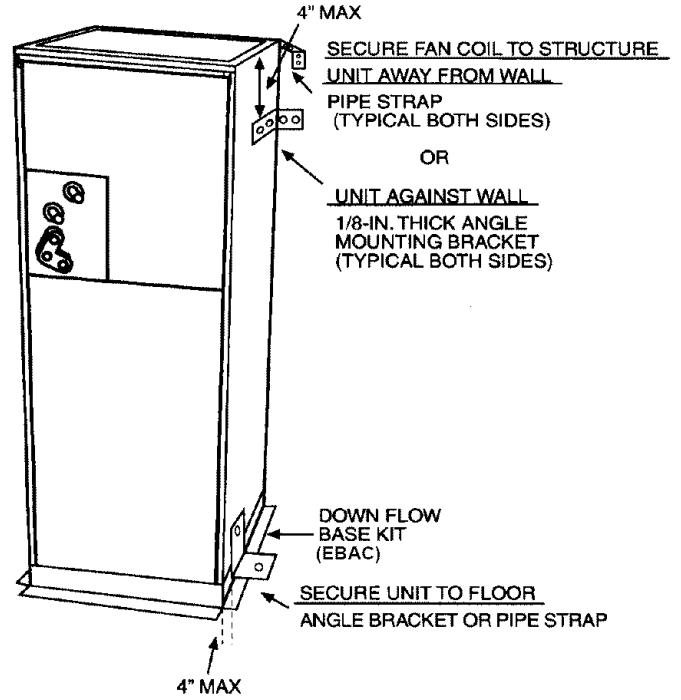
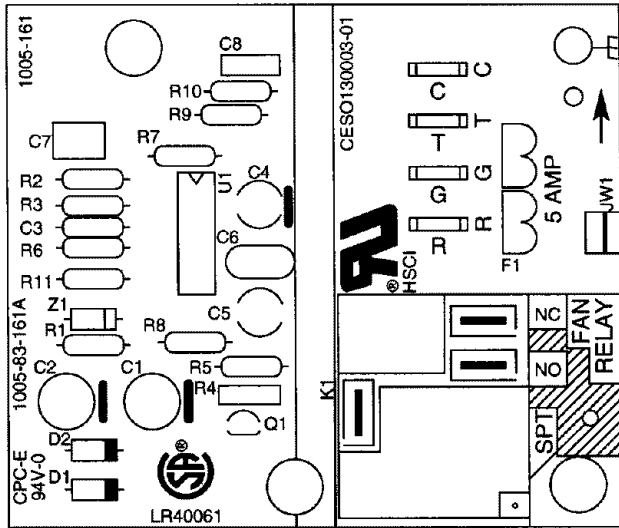

Figure 8 Fan Coil Printed Circuit Board



WARNING: Field wires on the line side of the disconnect found in the fan coil unit remain live, even when the pull-out is removed. Service and maintenance to incoming wiring can not be performed until the main disconnect switch (remote to the unit) is turned off. Failure to do so will result in electrical shock causing personal injury or death.

On units with a field installed disconnect with pull-out removed, service and maintenance can be safely performed on only the load side of the control package.

A. Line Voltage Connections

EBP / EBX units installed without electric heat require the use of a factory-authorized Power Plug Kit (EBAC01PLG1). This kit provides the electrical connections necessary to supply the EBP unit with 230-v power when electric heat is not present. This kit is required only on those EBP****A and EBX model applications which do not use electric heat. For units without electric heat:

1. Connect 208/230v power leads from field disconnect to yellow and black stripped leads.
2. Connect ground wire to unit ground lug.
3. When installing an electric heater, remove and discard power plug (if equipped) from fan coil and connect male plug from heater to female plug from unit wiring harness. (See Electric Heater Installation Instructions.)

B. 24-v Control System

CONNECTION TO UNIT

Wire low voltage in accordance with wiring label on the blower. (See Fig. 8, 10, 11, 12, 13 and 14). Use no. 18 AWG color-coded, insulated (35 C minimum) wire to make the low-voltage connections between the thermostat, the unit, and the outdoor equipment. If the thermostat is located more than 100 ft. from the unit (as measured along the low-voltage wire), use No. 16 AWG color-coded, insulated (35 C minimum) wire. All wiring must be NEC Class 1 and must be separated from incoming power leads. Refer to outdoor unit wiring instructions for any additional wiring procedure recommendations.

TRANSFORMER INFORMATION

Transformer is factory-wired for 230v operation. For 208v applications, disconnect the black wire from the 230v terminal on transformer and connect it to the 208v terminal. (See Fig. 15).

HEATER STAGING

CAUTION: If W2, W3, and E on any 3 stage heater (18, 20, 24, or 30kw), are individually connected as with outdoor thermostats or any other situation, emergency heat relay must be used.

The controls are factory circuited for single-stage operation. When 2 stages are desired, cut W3 at the W2 wire nut, strip and reconnect per the thermostat kit instruction. (See Fig. 13). When 3 stages are desired, cut the W2 wire nut off and discard. Strip W2, W3, and E and reconnect per thermostat kit instructions. (See Fig. 14).

Figure 10 Wiring Layout Air Conditioning Unit (Cooling Only)

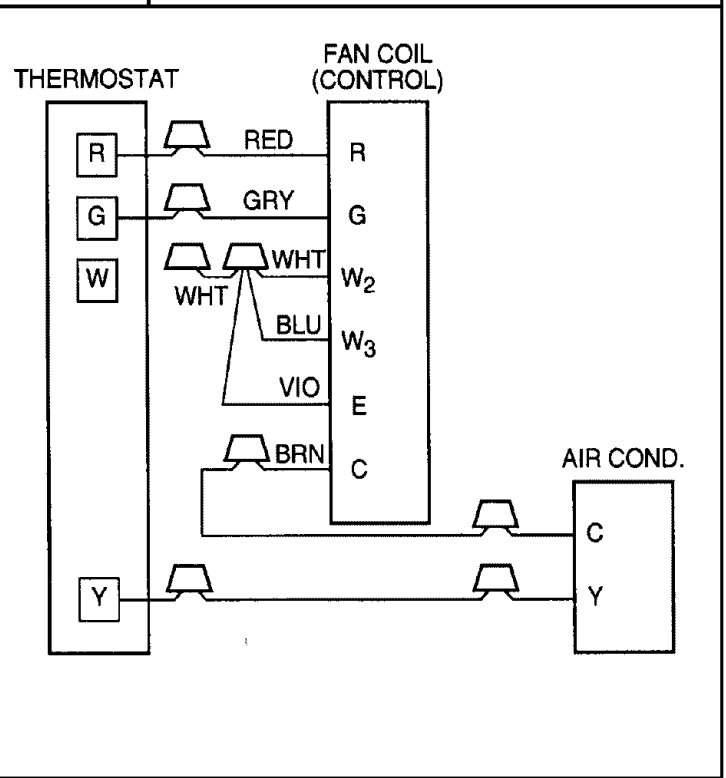
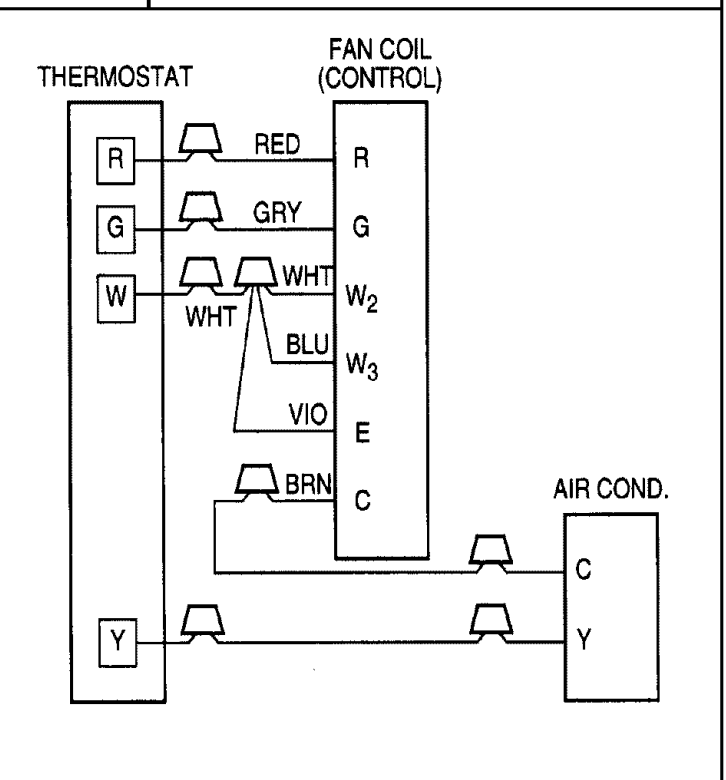

Figure 11 Wiring Layout Air Conditioning Unit (Cooling and 1-Stage Heat)



C. Ground Connections

WARNING: According to NEC, ANSI/NFPA 70, and local codes, the cabinet must have an uninterrupted or unbroken ground to minimize personal injury if an electrical fault should occur. The ground may consist of electrical wire or metal conduit when installed in accordance with existing electrical codes. If conduit connection uses reducing washers, a separate ground wire must be used. Failure to follow this warning could result in electric shock, fire, or death.

NOTE: Use UL-listed conduit and conduit connector for connecting supply wire(s) to unit to obtain proper grounding. Grounding may also be accomplished by using grounding lugs provided in control box.

D. Minimum CFM and Motor Speed Selection

Units with or without electric heaters require a minimum CFM. Refer to the unit wiring label to ensure that the fan speed selected is not lower than the minimum fan speed indicated.

Fan speed selection is done at the fan relay electronic fan board. To change motor speeds, disconnect fan lead used on relay terminal (SPT) and replace with motor speed tap desired. (See Fig. 16). Save insulating cap and place on motor lead removed from relay.

NOTE: In low static applications, lower motor speed tap should be used to reduce possibility of water being blown off coil.

All units have 2 or 3 motor speed taps. Low speed (red) is designed for mismatch outdoor unit applications. Medium speed (blue) is designed for straight matched operations. High speed (black) is used with high external static duct systems of straight matched systems.

PROCEDURE 4-REFRIGERANT TUBING

Field-supplied tubing must be of refrigerant grade. Suction tube must be insulated. Do not use damaged, dirty, or contaminated tubing because it may plug refrigerant flow-control device. **ALWAYS** evacuate the coil and field-supplied tubing to 500 microns before opening outdoor unit service valves.

CAUTION: Braze with Sil-Fos or Phos-copper on copper to copper joints and wrap a wet cloth around rear of fitting to prevent damage to TXV.

PROCEDURE 5-REFRIGERANT FLOW-CONTROL DEVICE

CAUTION: If using an EBX or an EBP model with field installed TXV in conjunction with a single-phase reciprocating compressor, a compressor hard start kit is required.

Check piston size shown on indoor unit rating plate to see if it matches required piston shown on outdoor unit rating plate. If it does not match, replace indoor piston with piston shipped with outdoor unit. The piston shipped with outdoor unit is correct for any approved indoor coil combination. (See Fig. 17). When changing piston, use a back-up wrench. Hand tighten hex nut, then tighten with wrench 1/2 turn. Do not exceed 30 ft-lbs.

Figure 12 Wiring Layout Heat Pump Unit (Cooling and 2-Stage Heat with No Outdoor Thermostat)

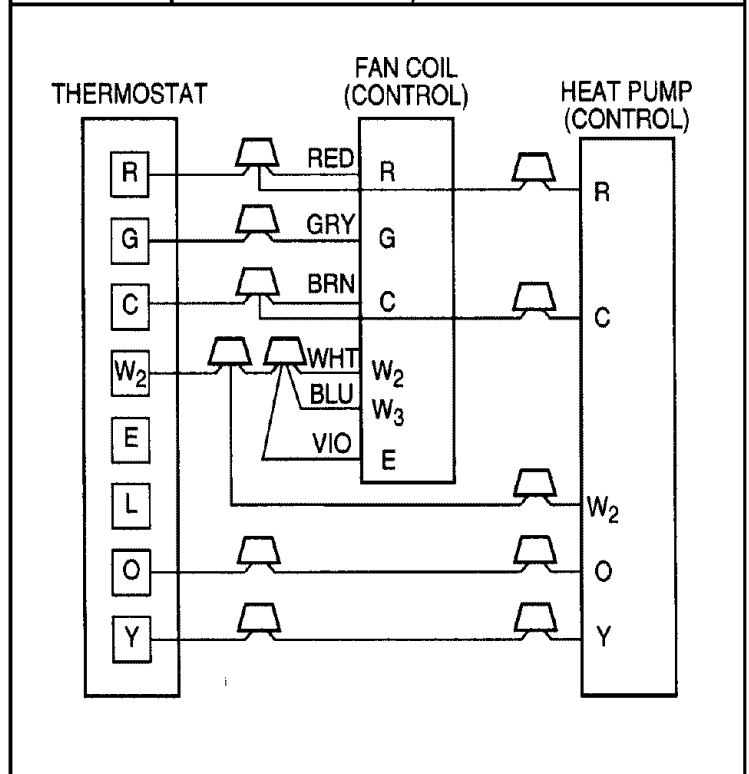

Figure 13 Wiring Layout Heat Pump Unit (Cooling and 2-Stage Heat with 1 Outdoor Thermostat)

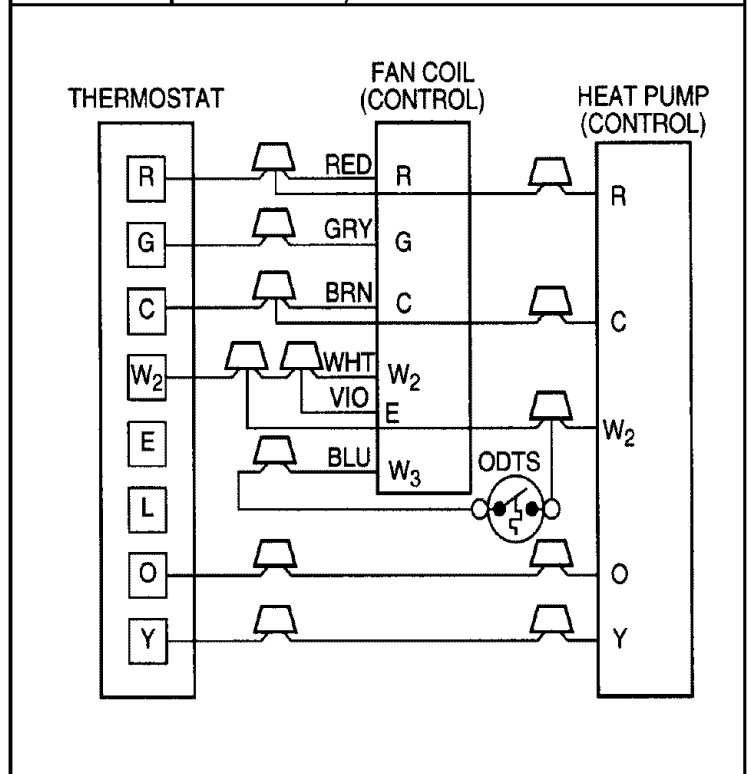
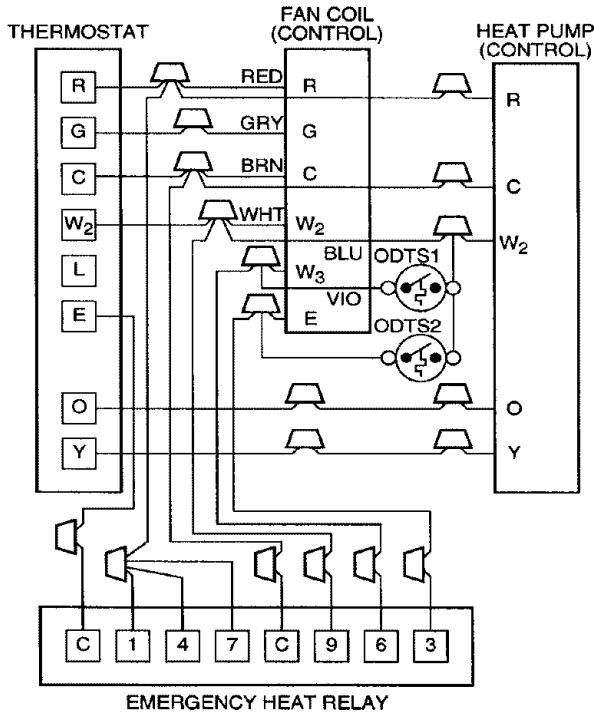

Figure 14

Wiring Layout Heat Pump Unit
(Cooling and 2-Stage Heat with 2 Outdoor
Thermostats)



PROCEDURE 6-CONDENSATE DRAINS

Units are equipped with primary and secondary 3/4-in. FPT drain connections. For proper condensate line installations see Fig. 2, 3, 5, 6 and 7. To prevent property damage and achieve optimum drainage performance, BOTH primary and secondary drain lines should be installed and include properly-sized condensate traps. (See Fig. 18). Factory-approved condensate traps are available (Kit No. EBAC01CTK1). Be sure to install plastic push-in plugs in unused condensate drain fittings. It is recommended that PVC fittings be used on the plastic condensate pan. Finger-tighten plus 1-1/2 turns. Do not over-tighten. Use pipe dope.

CAUTION: Shallow, running traps are inadequate and **DO NOT** allow proper condensate drainage. (See Fig. 19).

NOTE: When connecting condensate drain lines, avoid blocking filter access panel, thus preventing filter removal. After connection, prime both primary and secondary condensate traps.

NOTE: If unit is located in or above a living space where damage may result from condensate overflow, a field-supplied, external condensate pan should be installed underneath the entire unit, and a secondary condensate line (with appropriate trap) should be run from the unit into the pan. Any condensate in this external condensate pan should be drained to a noticeable place. As an alternative to using an external condensate pan, some localities may allow the use of a separate 3/4-in. condensate line (with appropriate trap) to a place where the condensate will be noticeable. The owner of the structure must be informed that when condensate flows from the secondary drain or external condensate pan, the unit requires servicing or water damage will occur.

Figure 15

Transformer Connections

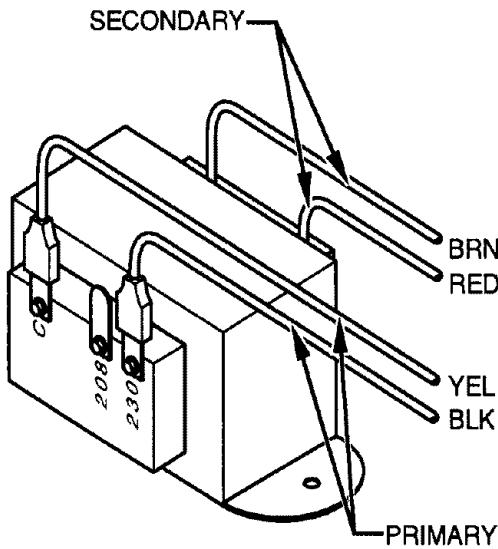

Figure 16

Fan Coil Relay and Speed Tap Terminal

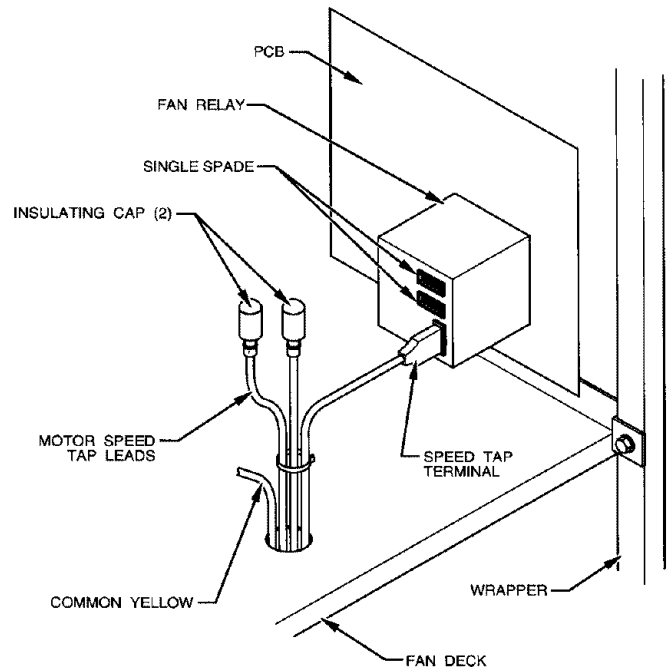

Figure 17 Refrigerant Flow-Control Device

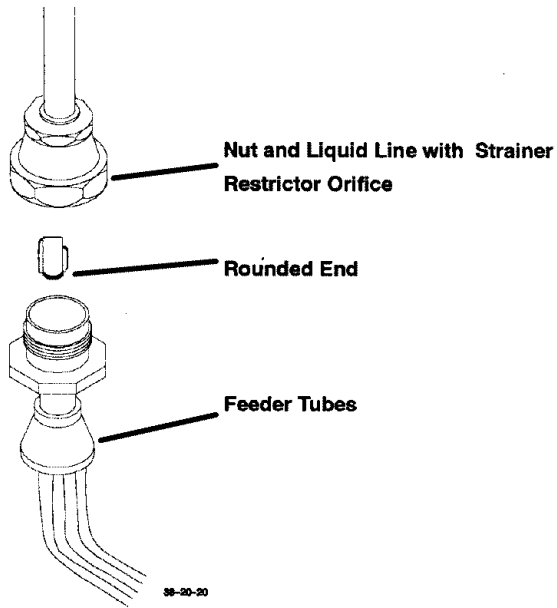
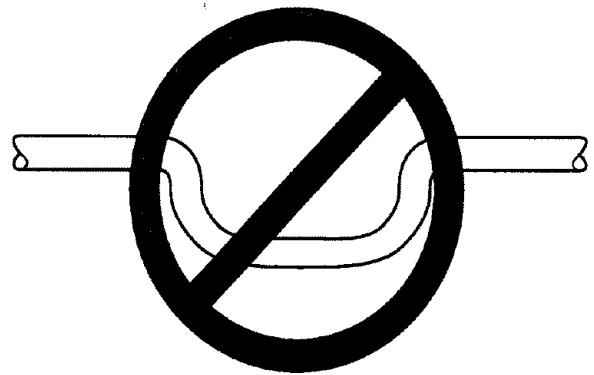

Figure 19 Insufficient Condensate Trap



DO NOT USE SHALLOW RUNNING TRAPS!

Figure 18 Recommended Condensate Trap

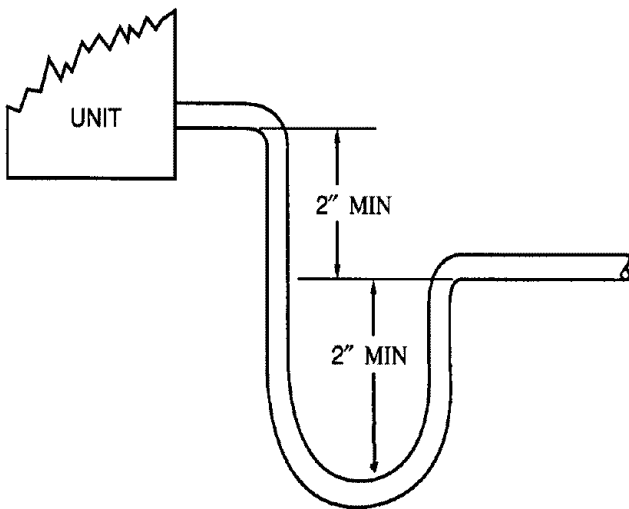
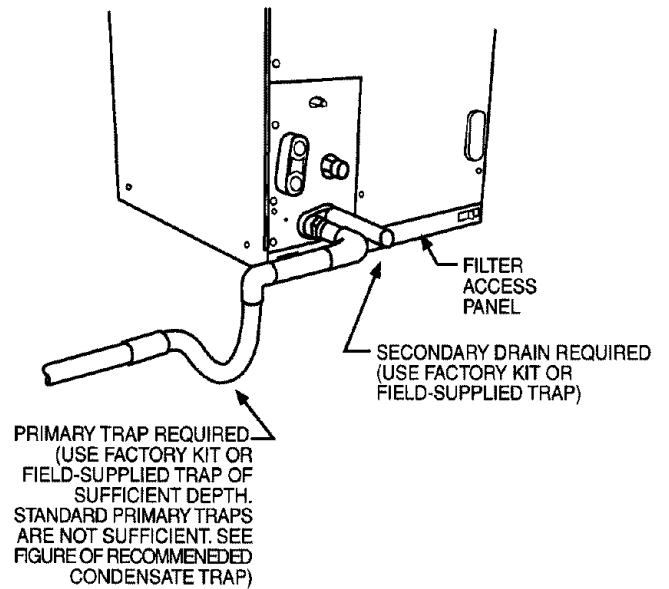

Figure 20 Condensate Drain



Install traps in the condensate lines as close to the coil as possible. (See Fig. 20). Make sure that the outlet of each trap is below its connection to the condensate pan to prevent condensate from overflowing the drain pan. **Prime all traps**, test for leaks, and insulate traps if located above a living area. Condensate drain lines should be pitched downward at a minimum slope of 1 in. for every 10 ft of length. Consult local codes for additional restrictions or precautions.

Figure 21 Wiring Layout of Electronic Air Cleaner to Fan Coil

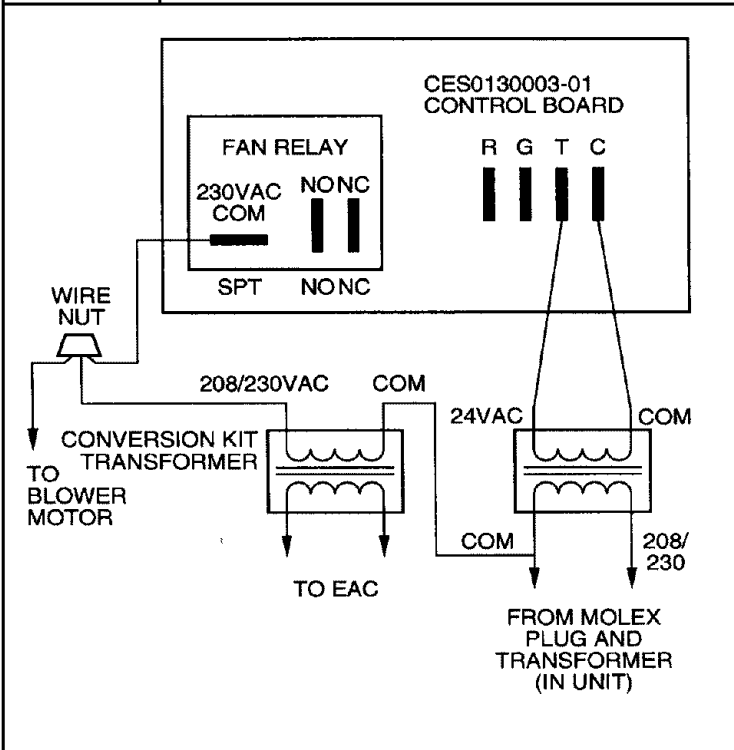
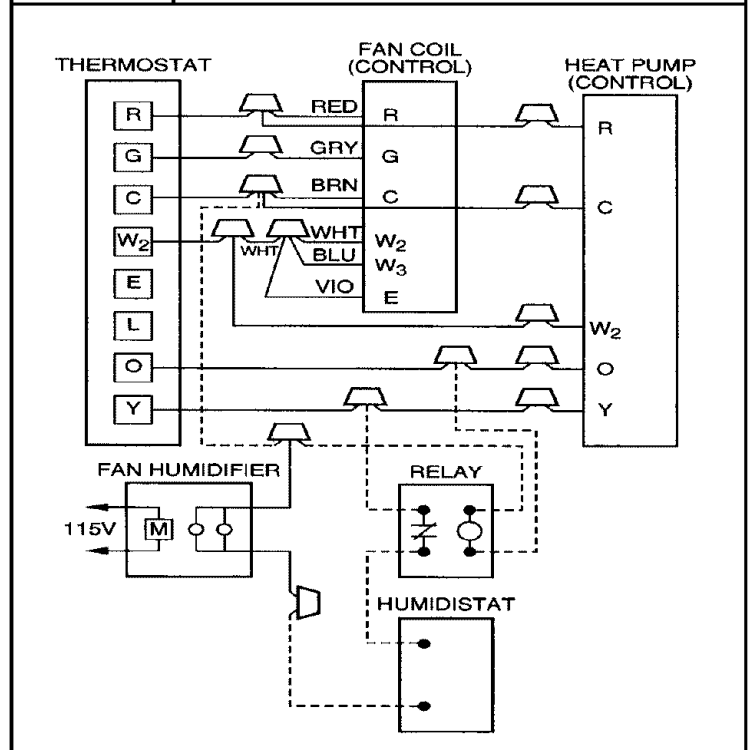

Figure 22 Wiring Layout of Humidifier to Heat Pump



PROCEDURE 7-ACCESSORIES

A. Electronic Air Cleaner

The Electronic Air Cleaner may be connected to fan coil as shown in Fig. 21. This method requires a field supplied transformer. See Electronic Air Cleaner literature for kit requirements.

B. Humidifier

Connect humidifier and humidistat to fan coil unit as shown in Fig. 22 and Fig. 23. The cooling lockout relay is optional (See Fig. 24).

PROCEDURE 8-SEQUENCE OF OPERATION

A. Continuous Fan

Thermostat closes R to G. G energizes fan relay on electronic fan board which completes circuit to indoor blower motor. When G is de-energized, there is a 90 sec delay before relay opens.

B. Cooling Mode

Thermostat energizes R to G, R to Y, and R to O (heat pump only). G energizes fan relay on electronic fan board which completes circuit to indoor blower motor. When G is de-energized, there is a 90 sec delay before fan relay opens.

C. Heat Pump Heating Mode

Thermostat energizes R to G and R to Y. G energizes fan relay on electronic fan board which completes circuit to indoor blower motor. When G is de-energized, there is a 90 sec delay before fan relay opens.

D. Heat Pump Heating with Auxiliary Electric Heat

Thermostat energizes R to G, R to Y, and R to W. G energizes fan relay on PCB which completes circuit to indoor blower motor. W energizes electric heat relay(s) which completes circuit to heater element(s). When W is de-energized, electric heat relay(s) open, turning off heater elements. When G is de-energized there is a 90 sec delay before fan relay opens.

E. Electric Heat or Emergency Heat Mode

Thermostat closes R to W. W energizes electric heat relay(s) which completes circuit to heater element(s). Blower motor is energized through normally closed contacts on fan relay. When W is de-energized, electric heat relay(s) opens.

START-UP PROCEDURES

Refer to outdoor unit Installation Instructions for system start-up instructions and refrigerant charging method details.

CAUTION: Never operate unit without a filter. Damage to blower motor or coil may result. Factory authorized filter kits must be used when locating the filter inside the unit. For those applications where access to an internal filter is impractical, a field-supplied filter must be installed in the return duct system.

CARE AND MAINTENANCE

To continue high performance and minimize possible equipment failure, it is essential that periodic maintenance be performed on this equipment. Consult your local dealer as to the proper frequency of maintenance contract. The ability to properly perform maintenance on this equipment requires certain mechanical skills and tools. If you do not possess these, contact your dealer for maintenance. The only consumer service recommended or required if filter replacement or cleaning on a monthly basis.

Figure 23 Wiring Layout of Humidifier to Fan Coil with Electric Heat

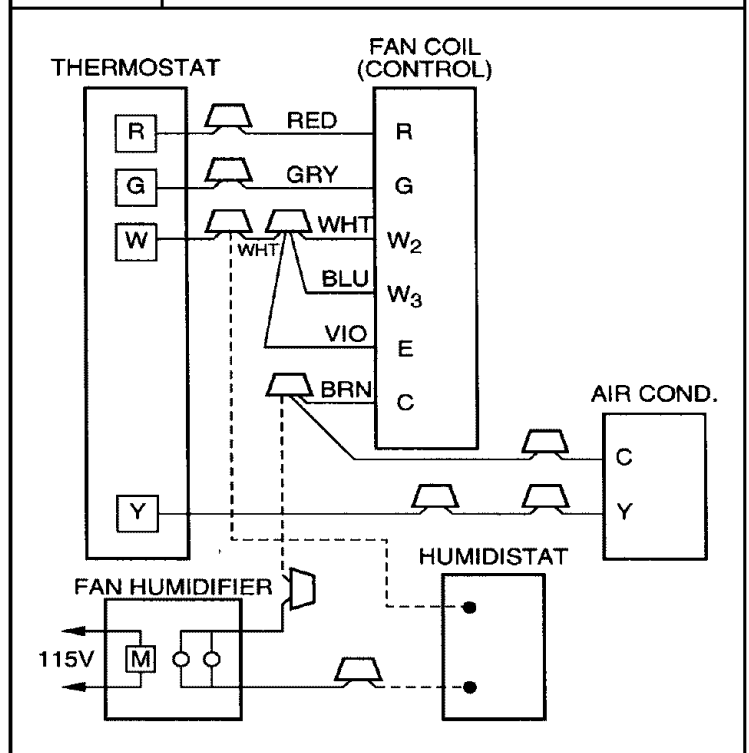
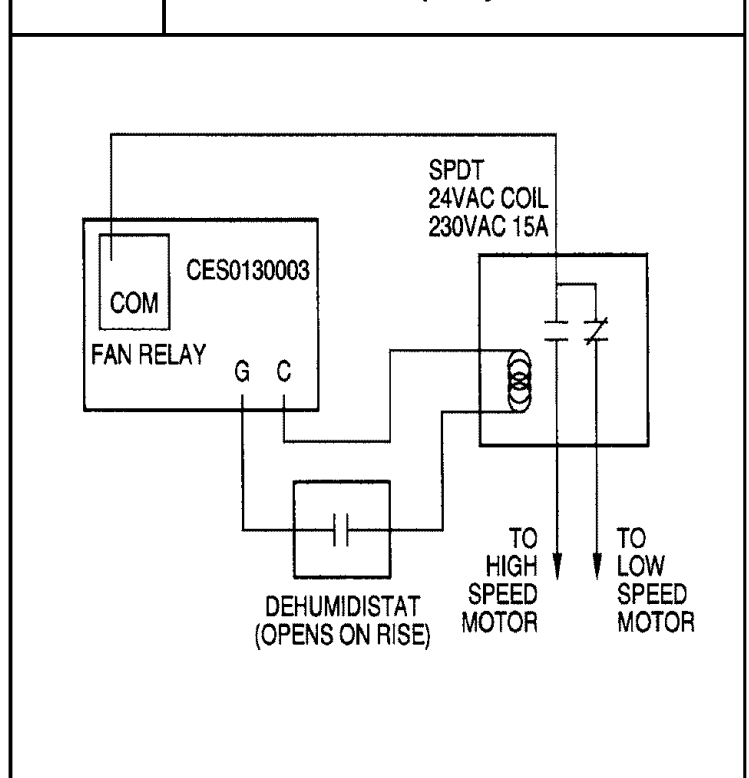

Figure 24 Latent Capacity Control



INTERNATIONAL COMFORT PRODUCTS
LIMITED WARRANTY CERTIFICATE
For Cooling & Heating Products

SAVE THIS CERTIFICATE. It gives you specific legal rights, and you may also have other rights which may vary from state to state and province to province.

If your unit needs servicing, contact a qualified dealer or qualified service technician of your choice. When requesting service, please have the model and serial number from each unit in your heating and/or cooling system readily available. If your dealer needs assistance, the distributor is available to provide support and we, in turn, support its efforts.

Fill in the installation date and model and serial numbers of the unit in the space provided below and retain this Limited Warranty for your files.

GENERAL TERMS

Subject to the conditions and limitations stated herein, during the term of this Limited Warranty, we will provide a replacement for any functional component part (as defined below) of your unit found to be defective in materials or workmanship. The term of this Limited Warranty is five years from installation on Residential Products and one year from installation on Commercial Products. Except as otherwise stated in the "Additional Terms" section, this Limited Warranty covers only the original purchaser and subsequent transferees, and only while the unit remains at the site of the original installation (except for mobile home installations), and only if the unit is installed inside the continental United States, Puerto Rico, Alaska, Hawaii or Canada. In addition, the Limited Warranty applies only if the unit is installed and operated in accordance with the printed instructions accompanying the unit, and in compliance with all applicable installation and building codes and good trade practices. As used in this Limited Warranty, "installation" means the original installation of the unit.

THERE ARE EXCEPTIONS to this Limited Warranty as described on the reverse side of this page. All replacement parts will be warranted for the unused portion of the warranty coverage period on the unit. The part to be replaced must be returned by the dealer to a distributor that sells products for International Comfort Products, in exchange for the replacement part. In lieu of providing a replacement part, we may, at our sole option, refund to you an amount equal to the distributor's component purchase price from us, or provide to you a credit equal to that amount to be applied toward the purchase of any new unit that we distribute. If a credit for a new unit is given in lieu of a replacement part, the rating plate from the unit being replaced must be submitted on a warranty claim, and your dealer must make the unit being replaced available to our distributor for disposition. As a condition to warranty coverage, the unit must receive yearly maintenance, as described in the owner's manual, by a dealer. Satisfactory proof of yearly service by a dealer may be required.

"Functional component parts" include only the following: blower motor, unit-mounted sensors & timers, condenser motor, evaporator coil, condenser coil, condenser fan, capacitor, transformer, single-phase strip heat elements, expansion device, reversing valve, solenoid valve, service valve, electronic and electro-mechanical control board, ignitor, ignition module, draft inducer assembly, burner pilot, gas valve, limit control, pressure switch, relays and contactors, blower wheel, interlock switch, crosslighter, pilot shield, gas & oil burners, oil pump assembly, accumulators and factory installed driers and strainers.

This Limited Warranty **DOES NOT COVER** any labor, material, refractory chambers, oil nozzles, refrigerant, refrigerant inspection and refrigerant reclaiming, freight and/or handling charges associated with any repair or replacement and such charges will be your responsibility.

To establish the installation date for any purpose under this Limited Warranty, you must retain the original records that can establish the installation date of your unit. If you do not provide such documents the start date of the term of this Limited Warranty will be based upon the date of unit manufacture, plus thirty (30) days. In establishing that the required yearly service has occurred, you must furnish proof of yearly service by a qualified service technician.

This Limited Warranty does not cover: (a) failure or damages caused by accident, abuse, negligence, misuse, riot, fire, flood, or Acts of God (b) damages caused by operating the unit where there is a corrosive atmosphere containing chlorine, fluorine, or any other damaging chemicals (other than those found in a normal residential environment) (c) damages caused by an unauthorized alteration or repair of the unit affecting its stability or performance (d) damages caused by improper matching or application of the unit or the unit's components (e) damages caused by failing to provide proper maintenance and service to the unit in accordance with this Limited Warranty Certificate and the printed instructions originally provided with the unit (f) any expenses incurred for erecting, disconnecting, or dismantling the unit (g) parts or supplies used in connection with service or maintenance, such as refrigerant, refractory chambers, oil nozzles, filters, or belts (h) damage, repairs, inoperation or inefficiency resulting from faulty installation or application (i) electricity or fuel costs or any increase in electricity or fuel cost whatsoever including additional or unusual use of supplemental electric heat (j) units which have not had the required yearly maintenance described elsewhere in this limited warranty.

In no event shall we be liable for any incidental, consequential, or special damages or expenses in connection with any use or failure of this unit.

We have not made, do not make, and hereby disclaim any implied condition or implied warranty of fitness for a particular use or purpose, and any implied condition or implied warranty of merchantability, to the fullest extent allowed by law. We make no express or implied warranties except as stated in this Limited Warranty certificate.

No one is authorized to change this Limited Warranty or to create for us any other obligation or liability in connection with this unit. Any implied warranties shall last for the term of the expressed warranty contained herein. Some states and provinces do not allow the exclusion or limitation of incidental or consequential damages or do not allow limitations on how long an implied warranty or condition lasts, so the above limitations or exclusions may not apply to you. The provisions of this Limited Warranty are in addition to and not a modification of or subtraction from any statutory warranties and other rights and remedies provided by law.

Please refer to reverse side of this page for additional terms.

Model No. _____

Serial No. _____ Date Installed _____

Effective on units installed After July 1, 2002.

USA: International Comfort Products Corporation (USA) • 650 Heil-Quaker Avenue • P.O. Box 128 • Lewisburg, Tennessee 37091 • (931-270-4100)
CANADA: International Comfort Products division of UTC Canada Corporation • 6060 Burnside Court, Unit 1, Mississauga, Ontario L5T 2T5 (905-795-8113).

Manufacturers of Airquest, Arcoaire, Clare, Comfortmaker, Dettson, Heil, Keeprite, Lincoln, Tempstar and other quality brand name private label products.

Part No. 401 06 1010 18 (Orig. 8/9/2002)

ADDITIONAL TERMS FOR RESIDENTIAL APPLICATIONS ONLY

The Additional Terms for the components listed below are in addition to, and subject to, the General Terms on the reverse side of this page.
Warranty coverage is limited to parts that fail due to defect in materials or workmanship during the specified term.

CENTRAL GAS & OIL FURNACE HEAT EXCHANGERS*

Gas Model Series: C9MPV, H9MPV, T9MPV, C9MPT, H9MPT, T9MPT, C9MPD, H9MPD, T9MPD: Limited Lifetime Warranty on heat exchangers. If a heat exchanger on one of these furnaces fails due to defect in the part, we will provide a replacement part or, at our option, credit toward the purchase of a new furnace manufactured by us. This additional Limited Warranty runs only to the original purchaser, and lasts only for as long as the original purchaser lives in the home where the furnace is initially installed.** It is not transferable to any subsequent owner. If the furnace was not installed in the home owned by the original purchaser, if the original purchaser sells the home to a subsequent owner, or if proof of original purchase cannot be provided, then the limited warranty is only for 20 years from the date of original installation.

Gas Model Series: GDL, GNL, TNE, TDE, NTC7, NDC7, NTP6, NDP6, TDE, NTV6, VNE: A replacement heat exchanger will be provided for any heat exchanger that fails in one of these furnaces due to defect for 25 years from the original date of installation.

Gas Model Series: NTC6, GNE, GDE, NDN6, NTG3, NDN3, FBF, NBF, NDF, NTN3, NTN6, NNE, N9MP1, N9MP2, FUH: A replacement heat exchanger will be provided for any heat exchanger that fails in one of these furnaces due to defect for 20 years from original date of installation.

Oil Model Series: OLR(105, 160, 182), OCF, OLF, OUF, NOLF, NOUF, OLB, OHB, ODH, FLO, MBO, LBO, NOMF: Limited Lifetime Warranty on heat exchangers. If a heat exchanger on one of these furnaces fails due to defect in the part, we will provide a replacement part or, at our option, credit toward the purchase of a new furnace manufactured by us. This additional Limited Warranty runs only to the original purchaser, and lasts only for as long as the original purchaser lives in the home where the furnace is initially installed.** It is not transferable to any subsequent owner. If the furnace was not installed in the home of the original purchaser, if the original purchaser sells the home to a subsequent owner, or if proof of original purchase cannot be provided, then the limited warranty is only for 20 years from the date of original installation.

Oil Fired Floor Furnace: NFO: A replacement heat exchanger will be provided for any heat exchanger that fails due to defect for 10 years from installation with the following limitation: during the sixth through tenth year, any credit toward your purchase of a component or toward the purchase of any new unit will be in an amount equal to the distributor's purchase price reduced by 20 percent for each year after the fifth year.

ADDITIONAL TERMS FOR OIL FURNACE APPLICATIONS ONLY

- 1) OIL BURNERS - A replacement for 5 years from date of original installation for Oil Burner Parts.
- 2) OPTIONAL ACCESSORIES AND FUNCTIONAL PARTS: A replacement for 5 years from date of original installation. (Refractory and oil nozzles not included)

GAS/ELECTRIC PACKAGED UNITS HEAT EXCHANGERS

Model series: PGAD, PGAA, PGMD, PGME, PGF, GPFM, PGC, GPCM: A replacement for 10 years from original date of installation.

COMPRESSORS:*

1) **Premium Model Units: HAC0, HAC2, HAC4, CAC0, CAC2, CAC4, KAC0, TCA0, TCA2, TCA4, HHP0, HHP2, HHP4, CHP0, CHP2, CHP4, TCH0, TCH2, TCH4, PGME, PYMC, PHAD, PGAD, PA95, PAPC, PAK, APK:** To the original purchaser a replacement for 10 years from original date of installation, only if the unit is installed with factory matched coils, except air conditioner condensing units with a nominal SEER of 10 may be matched with evaporator coils of the same nominal tonnage regardless of manufacturer and in accordance to factory recommendations. This limited 10-year warranty is not transferable to any subsequent owner. HOWEVER, if the unit was not installed in the home owned by the original purchaser, if the purchaser sells the home to a subsequent owner, or if proof of original purchase cannot be provided, then the limited warranty is only for 5 years from the original date of installation.**

2) **All Other Models: Air Conditioners, Heat Pumps, & Combination Gas/Electric Units: NAC0, NAC2, NHP0, NHP2, AO, A2, HO, H2, PGF, PGC, GPFM, GPCM, PAF, APFM, PHF, HPFM, PGAA, PGMD, PA55, PH55, PAPA, PYPA:** A replacement for 5 years from date of original installation, only if: (a) air conditioner condensing units with SEER rating in the range of 10 to 11 SEER are matched with evaporator coils of the same nominal tonnage regardless of manufacturer and in accordance to factory recommendations, or (b) heat pump condensing units are used with factory matched coils, unless written approval to do otherwise is obtained from manufacturer.

ADDITIONAL TERMS FOR COMMERCIAL APPLICATIONS ONLY

For purposes of this warranty a commercial application is one in which: the product has over 5 tons nominal cooling capacity, or is designed for operation with 3 phase electrical power, or is installed in a commercial establishment such as a beauty or hair salon, hospital, school, restaurant, church, hotel etc..

3-Phase Models: PGF, GPFM, GPF, PGAD, PGME, PGB, PGMG, PGMF, PGS, PGE, APE, PAE, PAB, PAMD, PAS, PAF, APFM, APF, PHB, PHE, PYMD, HPB, PHS, CAC, ACC, CAE, ACE, CHC, HCC, CHE, HCE:

The additional Terms of the components listed below are in addition to and subject to the General Terms on the reverse side of this page.

- 1) **GAS FIRED HEAT EXCHANGERS (ALL MODELS):*** A replacement for 10 years from date of original installation.
- 2) **COMPRESSORS (ALL MODELS):*** A replacement for 5 years from date of original installation.
- 3) **OPTIONAL ACCESSORIES AND FUNCTIONAL COMPONENT PARTS (ALL MODELS):***
A replacement for 1 year from date of original installation.
- 4) **COMMERCIAL OIL MODELS: OLR210, OLR350, OTF210, AMT3, AMT4, AMP3:** Ten(10) Year Limited Warranty on heat exchangers.
*To receive advantage of your limited warranty, you must provide proof of yearly service by a qualified service technician.
**To receive advantage of your warranty, you must retain the original records that can establish the installation date and proof of purchase of the unit.

MINI SPLITS:

Summary - Mini Splits Warranted for one (1) year on all replacement parts.

Additional terms for Mini Splits:

The additional Terms of the components listed below are in addition to, and subject to, the General Terms on the reverse side of this page.

1) **Compressors (All Models):** A replacement compressor will be provided for all compressors that fail due to defect for 5 years from date of original installation.

2) **Optional Accessories and Functional Components Parts (All Models):**

A replacement part will be provided for all parts that fail due to defect for one (1) year from date of original installation.

Failure to maintain the equipment through annual maintenance by a qualified service technician shall void the warranty. Proof of service will be required with all warranty claims. Proof of purchase and installation date must be submitted with all claims.