

INSTALLATION INSTRUCTIONS

*SC Upflow / Horizontal Model

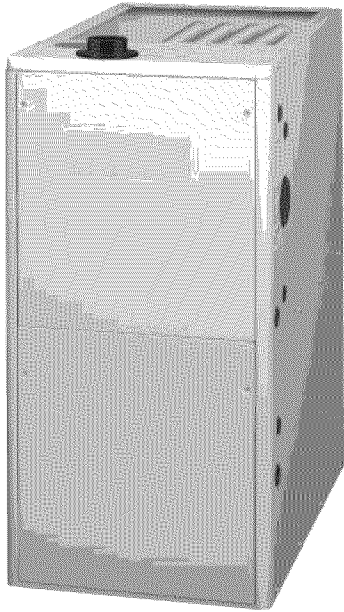
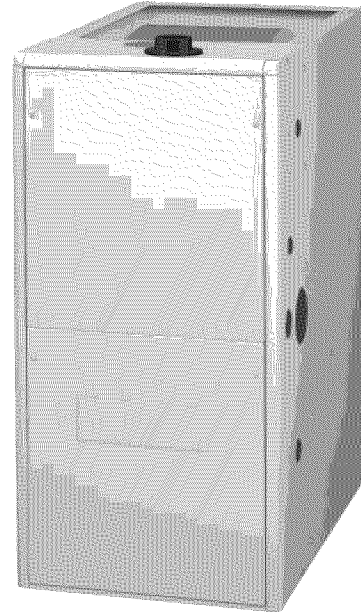

*SL Downflow Model

⚠ WARNING:**FIRE OR EXPLOSION HAZARD**

- Failure to follow safety warnings exactly could result in serious injury or property damage.
- Installation and service must be performed by a qualified installer, service agency or the gas supplier.
- Do not store or use gasoline or other flammable vapors and liquids in the vicinity of this or any other appliance.

WHAT TO DO IF YOU SMELL GAS

- Do not try to light any appliance.
- Do not touch any electrical switch; do not use any phone in your building.
- Leave the building immediately.
- Immediately call your gas supplier from a neighbor's phone. Follow the gas supplier's instructions.
- If you cannot reach your gas supplier, call the fire department.

⚠ AVERTISSEMENT**RISQUE D'INCENDIE OU D'EXPLOSION**

- Le non-respect des avertissements de sécurité pourrait entraîner des blessures graves, la mort ou des dommages matériels.
- L'installation et l'entretien doivent être effectués par un installateur qualifié, un organisme de service ou le fournisseur de gazstaller, service agency or the gas supplier.
- Ne pas entreposer ni utiliser de l'essence ni d'autres vapeurs ou liquides inflammables dans le voisinage de cet appareil, ni de tout autre appareil.

QUE FAIRE S'IL Y A UNE ODEUR DE GAZ

- Ne pas tenter d'allumer aucun appareil.
- Ne toucher à aucun interrupteur électrique; n'utiliser aucun téléphone dans le bâtiment.
- Évacuer l'immeuble immédiatement.
- Appeler immédiatement le fournisseur de gaz en employant le téléphone d'un voisin. Respecter à la lettre les instructions du fournisseur de gaz.
- Si personne ne répond, appeler le service des incendies.

TABLE OF CONTENTS

IMPORTANT SAFETY INFORMATION	4	CIRCULATING AIR REQUIREMENTS	14
REQUIREMENTS & CODES	4	Plenums & Air Ducts.....	14
Combustion Air Quality	5	Supply Air Connections	15
Operation of Furnace During Construction.....	5	Upflow / Horizontal Furnaces	15
Installation in a Garage.....	6	Downflow Furnaces.....	15
Clearances to Combustible Materials.....	6	Return Air Connections	15
Heating Load.....	6	Upflow / Horizontal Furnaces	15
COMBUSTION AIR & VENTING REQUIREMENTS....	7	Side Return Installations	15
General Information.....	8	Bottom Return Installations	15
Direct Vent Furnaces	8	Downflow Furnaces.....	15
Conventional Furnaces - Confined Spaces	8	Acoustical Treatments.....	15
Air From Inside.....	8	FURNACE INSTALLATION	16
Outdoor Air from a Crawl Space or Vented Attic.....	9	General Requirements	16
Outdoor Air Using Vertical Ducts	9	Upflow Installation.....	16
Outdoor Air Using Horizontal Ducts.....	9	Side Return Air Inlet	16
Air Directly Through an Exterior Wall	10	Bottom Return Air Inlet	16
Alternate Method of Providing air from Outside	10	Downflow Installation	16
Conventional Furnaces - Unconfined Spaces	10	Installation on a Concrete Slab	16
Category IV Venting.....	10	Horizontal Installation	16
Vent Pipe Material.....	11	Special Instructions for SC038-23A Furnaces ...	17
Vent Pipe Length & Diameter.....	11	Inducer & Venting Options.....	18
Vent Pipe Installation.....	12	Inducer Assembly Rotation.....	18
Outdoor Terminations - Horizontal Venting.....	12	Pressure Switch Tubing.....	18
Outdoor Terminations - Vertical Venting	13	Alternate Pressure Switch Location.....	20
Vent Freezing Protection	13	Accessories.....	20
Existing Installations.....	14	Finish Flange	20
Condensate Disposal	14	Rubber Grommets	20
		PVC Tee, Reducer, & Hose Barbs	21
		Optional PVC pipe Installation	21
		Condensate Drain Lines	21
		Bottom Panel Removal	22
		Alternate Bottom Panel Removal.....	22

GAS SUPPLY & PIPING	23	FIGURES & TABLES	33
Leak Check	23	Figure 31 - Furnace Dimensions	33
High-Altitude Application	24	Airflow Data.....	34
Conversion to LP / Propane	26	Table 6 - Upflow / Horizontal Gas Furnaces.....	34
ELECTRICAL WIRING.....	26	Table 7 - Downflow Gas Furnaces	36
Line Voltage Wiring	27	Troubleshooting.....	36
Grounding.....	27	Table 8 - Control Board Fault Conditions.....	36
Thermostat / Low Voltage Connections	28	Electrical Information	37
Heat Anticipator.....	28	Figure 32 - Wiring Diagram	37
Twinning	28	Gas Information	38
START-UP & ADJUSTMENTS.....	29	Table 9 - Gas Flow Rates	38
Pre-Start Checklist.....	29	Table 10 - Gas Pipe Capacities	38
Start-Up Procedures.....	29	Table 11 - High Altitude Deration Chart for Propane Gas	39
Verifying & Adjusting Input Rate	29	Table 12 - Natural Gas Heating Values	39
Verifying & Adjusting Temperature Rise.....	30	Table 13 - High Altitude Deration Chart for Nat. Gas - High Heating Values.....	40
Verifying Burner Operation	30	Table 14 - High Altitude Deration Chart for Nat. Gas - Low Heating Values.....	40
Verifying Operation of the Supply Air Limit Switch.....	30	Venting Information	41
OPERATING SEQUENCE	30	Table 15 - Vent Termination Clearances.....	41
Heating Cycle	30	Figure 33 - Horizontal & Vertical Venting	42
Cooling Cycle.....	31	Figure 34 - Upflow Options.....	43
Fan Mode.....	31	Figure 35 - Downflow Options	44
DESCRIPTION OF COMPONENTS	31	Figure 36 - Horizontal Options - 1 Pipe Furnaces.....	45
MAINTENANCE	31	Figure 37 - Horizontal Options - 2-pipe Furnaces.....	46
Air Filters.....	32	Location of Furnace Components.....	47
Blower Compartment	32	Figure 38 - Furnace Components	47
Cleaning of Burners.....	32	INSTALLATION / PERFORMANCE CHECKLIST	48
Vent System.....	32		
Heat Exchanger & Burner Maintenance	32		
Lubrication	32		

IMPORTANT SAFETY INFORMATION

Please read all instructions before servicing this equipment. Pay attention to all safety warnings and any other special notes highlighted in the manual. Safety markings are used frequently throughout this manual to designate a degree or level of seriousness and should not be ignored. **WARNING** indicates a potentially hazardous situation that if not avoided, could result in personal injury or death. **CAUTION** indicates a potentially hazardous situation that if not avoided, may result in minor or moderate injury or property damage.

REQUIREMENTS & CODES

WARNING:

The information listed below must be followed during the installation, service, and operation of this furnace. Failure to follow safety recommendations could result in possible damage to the equipment, serious personal injury or death.

- This furnace must be installed in accordance with these instructions, all applicable local building codes and the current revision of the National Fuel Gas Code (NFPA54/ANSI Z223.1) or the Natural Gas and Propane Installation Code, CAN/CGA B149.1.
 - Use only with type of gas approved for this furnace. Refer to the furnace rating plate.
 - Install this furnace only in a location and position as specified on page 6.
 - Provide adequate combustion and ventilation air to the furnace space as specified on pages 7 - 10.
 - Provide adequate clearances around the vent air intake terminal as specified in Figures 6 - 9 (pages 12 - 13).
 - Combustion products must be discharged outdoors. Connect this furnace to an approved vent system only, as specified on pages 10 - 14.
 - Never test for gas leaks with an open flame. Use a commercially available soap solution to check all connections. See pages 23 - 24.
 - This furnace is designed to operate with a maximum external pressure rise of 0.5 inches of water column. Consult Tables 6 & 7 (pages 34 - 36), and the rating plate for the proper circulating air flow and temperature rise. It is important that the duct system be designed to provide the correct flow rates and external pressure rise. An improperly designed duct system can result in nuisance shutdowns, and comfort or noise issues.
 - When supply ducts carry air circulated by the furnace to areas outside the space containing the furnace, the return air shall also be handled by duct(s) sealed to the furnace casing and terminating in the conditioned space. See pages 14 - 15.
 - A gas-fired furnace for installation in a residential garage must be installed as specified on page 6.
- This furnace may be used for temporary heating of buildings or structures under construction. See the guidelines listed on page 5.
 - This furnace is not approved for installation in mobile homes. Installing this furnace in a mobile home could cause fire, property damage, and/or personal injury.
 - The Commonwealth of Massachusetts requires compliance with regulation 248 CMR 4.00 and 5.00 for installation of through – the – wall vented gas appliances as follows:
 1. For direct-vent appliances, mechanical-vent heating appliances or domestic hot water equipment, where the bottom of the vent terminal and the air intake is installed below four feet above grade the following requirements must be satisfied:
 - a.) A carbon monoxide (CO) detector and alarm shall be placed on each floor level where there are bedrooms. The detector shall comply with NFPA 720 (2005 Edition) and be mounted in the living area outside the bedroom(s).
 - b.) A (CO) detector shall be located in the room that houses the appliance or equipment and shall:
 - Be powered by the same electrical circuit as the appliance or equipment. Only one service switch shall power the appliance and the (CO) detector;
 - Have battery back-up power;
 - Meet ANSI/UL 2034 Standards and comply with NFPA 720 (2005 Edition); and Approved and listed by a Nationally Recognized Testing Laboratory as recognized under 527 CMR.
 - c.) A Product-approved vent terminal must be used, and if applicable, a product-approved air intake must be used. Installation shall be in strict compliance with the manufacturer's instructions. A copy of the installation instructions shall remain with the appliance or equipment at the completion of the installation.
 - d.) A metal or plastic identification plate shall be mounted at the exterior of the building, four feet directly above the location of vent terminal. The plate shall be of sufficient size, easily read from a distance of eight feet away, and read "Gas Vent Directly Below".
 2. For direct-vent appliances, mechanical-vent heating appliances or domestic hot water equipment where the bottom of the vent terminal and the air intake is installed above four feet above grade the following requirements must be satisfied:
 - a.) A (CO) detector and alarm shall be placed on each floor level where there are bedrooms. The detector shall comply with NFPA 720 (2005 Edition) and be mounted in the living area outside the bedroom(s).
 - b.) The (CO) detector shall:
 - Be located in the room that houses the appliance or equipment;
 - Be hard-wired or battery powered or both.

- Shall comply with NFPA 720 (2005 Edition).
- c.) A product-approved vent terminal must be used, and if applicable, a product-approved air intake must be used. Installation shall be in strict compliance with the manufacturer's instructions. A copy of the installation instructions shall remain with the appliance or equipment at the completion of the installation.

Combustion Air Quality

CAUTION:

Combustion air must not be drawn from a corrosive atmosphere.

To maximize heat exchanger life, the combustion air must be free of chemicals that can form corrosive acidic compounds in the combustion gases. The recommended source of combustion air is to use outdoor air. However, the use of indoor air in most applications is acceptable except as listed:

- If the furnace is installed as a single pipe installation in a confined space, it is required that the necessary combustion air come from the outdoors by way of attic, crawl space, air duct, or direct opening. For Installations in confined spaces, see pages 8 - 10 for combustion air requirements.
- Installations in these locations may require outdoor air for combustion, due to chemical exposures:
 - Commercial buildings
 - Buildings with indoor pools
 - Furnaces installed in laundry rooms
 - Furnaces installed in hobby or craft rooms
 - Furnaces installed near chemical storage areas
- Exposure to the following substances in the combustion air supply may require outdoor air for combustion:
 - Permanent wave solutions
 - Chlorinated waxes and cleaners
 - Chlorine based swimming pool chemicals
 - Water softening chemicals
 - De-icing salts or chemicals
 - Carbon Tetrachloride
 - Halogen type refrigerants
 - Cleaning solvents (perchloroethylene)
 - Printing inks, paint removers, varnishes, etc.
 - Hydrochloric Acid
 - Cements and glues
 - Antistatic fabric softeners
 - Masonry acid washing materials

Operation of Furnace During Construction

CAUTION:

Failure to follow these instructions will void the factory warranty and may significantly reduce the life or the performance of the furnace, and/or result in other unsafe conditions. It is the responsibility of the installing contractor to insure these provisions are met.

Operating gas furnaces in construction environments can cause a variety of problems with the furnace. Proper use of commercial portable space heating equipment during construction is recommended. This gas furnace may be used during construction if it is not in violation of any applicable codes and the following criteria are met:

- The installation must meet all applicable codes. The furnace must be permanently installed according to the instructions supplied with the furnace including electrical supply, gas supply, duct work and venting. The furnace must be controlled by a thermostat properly installed according to the instructions supplied with the furnace and thermostat. The installation must include a properly installed filter in the return air system with no by-pass air. The filter must be inspected frequently and replaced when necessary.
- Combustion air must be supplied from outside the structure and located such that dust and gases from construction activity are not introduced into the combustion system.
- Provisions must be made to insure that condensate does not freeze in the furnace or condensate drain lines during operation and during idle times; for example, overnight if turned off.
- Before occupying the structure: The filter must be replaced or cleaned, the duct work must be inspected and cleaned of any construction debris, and the furnace must be cleaned and/or repaired if found to be dirty, damaged, or malfunctioning in any way by a qualified HVAC technician. The furnace shall be inspected and approved by applicable local authority even if this requires redundant inspections.
- Serial numbers for furnaces used during construction must be submitted in writing (fax and email also acceptable). This information will be used to track the long-term affects of the use during construction on furnaces. Proof of this submittal shall be available for the final inspection of the furnace prior to occupancy.
- This furnace is designed to operate with return air temperatures in ranges normally found in occupied residences, including setbacks. Minimum continuous return temperature must not be below 60° F (15° C). Occasionally a temporary return temperature of 55° F (12° C) is acceptable. However, operation with a return temperature below 55° F (12° C) is not allowed.

Installation in a Garage

WARNING:

Do not place combustible material on or against the furnace cabinet or within 6 inches of the vent pipe. Do not place combustible materials, including gasoline or any other flammable vapors and liquids, in the vicinity of the furnace.

This gas-fired furnace may be installed in a residential garage with the provision that the burners and igniter are located no less than 18 inches (457mm) above the floor. The furnace must be located or protected to prevent physical damage by vehicles.

Clearances to Combustible Materials

This furnace is Design Certified in the U.S. and Canada by CSA International for the minimum clearances to combustible materials. **NOTE:** The furnace is listed for installation on combustible or non-combustible flooring. However, wood is the only combustible flooring allowed for installation. Downflow models must use the appropriate subbase kit when installing over a wood floor. To obtain model number and specific clearance information, refer to the furnace rating plate, located inside of the furnace cabinet.

Access for positioning and servicing the unit must be considered when locating unit. The need to provide clearance for access to panels or doors may require clearance distances over and above the requirements. **Allow 24 inches minimum clearance from the front of the unit. However 36 inches is strongly recommended.** See Table 1 for minimum clearance requirements.

CLEARANCES TO COMBUSTIBLE MATERIALS			
Left Side.....0 Inches	Top.....0 Inches	Right Side.....0 Inches	Front.....†4 Inches
Vent.....0 Inches	Back.....0 Inches		
†Allow 24 in. minimum clearance for servicing. Recommended clearance is 36 in.			
			

Table 1. Minimum Clearances to Combustible Materials

Heating Load

This furnace should be sized to provide the design heating load requirement. Heating load estimates can be made using approved methods available from Air Conditioning Contractors of America (Manual J); American Society of Heating, Refrigerating, and Air Conditioning Engineers; or other approved engineering methods. **Excessive oversizing of the furnace could cause the furnace and/or vent to fail prematurely.**

The ductwork should be appropriately sized to the capacity of the furnace to ensure its proper airflow rating. For installations above 2,000 ft., the furnace should have a sea level input rating large enough that it will meet the heating load after deration for altitude.

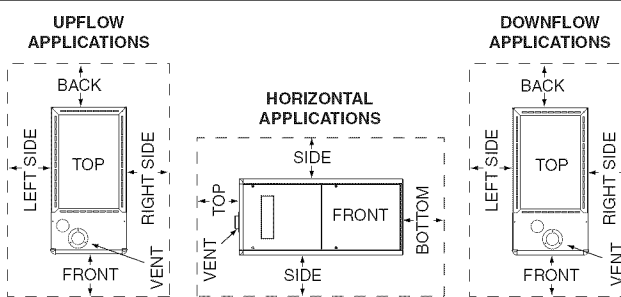
The information listed below is for reference purposes only and does not necessarily have jurisdiction over local or state codes. Always consult with local authorities before installing any gas appliance.

Combustion and Ventilation Air

- US: National Fuel Gas Code (NFGC), Air for Combustion and Ventilation
- CANADA: Natural Gas and Propane Installation Codes (NSCNGPIC), Venting Systems and Air Supply for Appliances

Duct Systems

- US and CANADA: Air Conditioning Contractors Association (ACCA) Manual D, Sheet Metal and Air Conditioning - National Association (SMACNA), or American Society of Heating, Refrigeration, and Air Conditioning Engineers (ASHRAE) Fundamentals Handbook

Electrical Connections

- US: National Electrical Code (NEC) ANSI/NFPA 70
- CANADA: Canadian Electrical Code CSA C22.1

Gas Piping and Gas Pipe Pressure Testing

- US: NFGC and National Plumbing Codes
- CANADA: NSCNGPIC

General Installation

- US: Current edition of the NFGC and the NFPA 90B. For copies, contact the National Fire Protection Association Inc., Batterymarch Park, Quincy, MA 02269; or American Gas Association, 400 N. Capitol, N.W., Washington DC 20001 or www.NFPA.org
- CANADA: NSCNGPIC. For a copy, contact Standard Sales, CSA International, 178 Rexdale Boulevard, Etobicoke (Toronto), Ontario, M9W 1R3 Canada

Safety

- US: (NFGC) NFPA 54–1999/ANSI Z223.1 and the Installation Standards, Warm Air Heating and Air Conditioning Systems ANSI/NFPA 90B.
- CANADA: CAN/CGA-B149.1 and .2–M00 National Standard of Canada. (NSCNGPIC)

COMBUSTION AIR & VENTING REQUIREMENTS

WARNING:

CARBON MONOXIDE POISONING HAZARD
Failure to follow the steps outlined below for each appliance connected to the venting system being placed into operation could result in carbon monoxide poisoning or death.

The following steps shall be followed with each individual appliance connected to the venting system being placed in operation, while all other appliances connected to the venting system are not in operation:

1. Seal any unused openings in the venting system.
2. Inspect the venting system for proper size and horizontal pitch, as required in the *National Fuel Gas Code, ANSI Z223.1/NFPA 54* or the *CSA B149.1, Natural Gas and Propane Installation Codes* and these instructions. Determine that there is no blockage or restriction, leakage, corrosion and other deficiencies which could cause an unsafe condition.
3. As far as practical, close all building doors and windows and all doors between the space in which the appliance(s) connected to the venting system are located and other spaces of the building.
4. Close fireplace dampers.
5. Turn on clothes dryers and any appliance not connected to the venting system. Turn on any exhaust fans, such as range hoods and bathroom exhausts, so they are operating at maximum speed. Do not operate a summer exhaust fan.
6. Follow the lighting instructions. Place the appliance being inspected into operation. Adjust the thermostat so appliance is operating continuously.
7. Test for spillage from draft hood equipped appliances at the draft hood relief opening after 5 minutes of main burner operation. Use the flame of a match or candle.
8. If improper venting is observed during any of the above tests, the venting system must be corrected in accordance with the *National Fuel Gas Code, ANSI Z223.1/NFPA 54* and/or *CSA B149.1, Natural Gas and Propane Installation Codes*.
9. After it has been determined that each appliance connected to the venting system properly vents when tested as outlined above, return doors, windows, exhaust fans, fireplace dampers and any other gas-fired burning appliance to their previous conditions of use.

AVERTISSEMENT:

RISQUE D'EMPOISONNEMENT AU MONOXYDE DE CARBONE

Le non-respect des consignes suivantes portant sur chacun des appareils raccordés au système d'évacuation mis en service pourrait entraîner l'empoisonnement au monoxyde de carbone ou la mort. Les consignes suivantes doivent être observées pour chaque appareil raccordé au système d'évacuation mis en service si les autres appareils raccordés au système ne sont pas en service:

1. Sceller toute ouverture non utilisée de la système d'évacuation;
2. S'assurer que la système d'évacuation présente des dimensions et une pente horizontale conformes à la norme ANSI Z223.1/NFPA 54, intitulée National Fuel Gas Code ou aux codes d'installation CSA-B149.1, ainsi qu'aux présentes instructions. S'assurer que la système d'évacuation n'est pas bloquée, restreinte, corrodée, qu'elle ne fuit pas et qu'elle ne présente aucun autre défaut potentiellement dangereux;
3. Dans la mesure du possible, fermer toutes les portes et fenêtres du bâtiment, et toutes les portes entre la pièce où se trouve l'appareil raccordé à la système d'évacuation et les autres pièces du bâtiment.
4. Fermer les registres des foyers;
5. Mettre en service les sècheuses et tout autre appareil qui n'est pas raccordé à la système d'évacuation. Faire fonctionner à régime maximal tout ventilateur d'évacuation, tel que les hottes de cuisinière et les ventilateurs de salles de bains. Ne pas mettre en service les ventilateurs d'été.
6. Respecter les instructions d'allumage. Mettre en service l'appareil à l'essai. Régler le thermostat de manière à ce que l'appareil fonctionne sans interruption;
7. Vérifier s'il y a débordement à l'orifice d'évacuation du coupe tirage des appareils dotés d'un coupe tirage 5 minutes après l'allumage du brûleur principal. Utiliser la flamme d'une allumette ou d'une chandelle.
8. Si l'on constate, au cours de l'un des essais qui précèdent, que l'évacuation est déficiente, corriger le système d'évacuation conformément à la norme ANSI Z223.1/NFPA 54, National Fuel Gas Code, et (ou) aux codes d'installation CSA B149.1.
9. Après avoir déterminé que tous les appareils raccordés à la système d'évacuation évacuent correctement tel que prescrit ci-dessus, rouvrir les portes et les fenêtres et remettre les ventilateurs d'évacuation, les registres de foyers et tout autre appareil fonctionnant au gaz à leur état de fonctionnement initial.

General Information

WARNING:

Furnace installation using methods other than those described in the following sections must comply with the National Fuel Gas Code (NFGC) and all applicable local codes.

- Instructions for determining the adequacy of combustion air for an installation can be found in the current revision of the NFGC (ANSI Z223.1 / NFPA54). **Consult local codes for special requirements.** These requirements are for US installations as found in the NFGC.
- The requirements in Canada (B149.1) are structured differently. Consult with B149.1 and local code officials for Canadian installations.

This condensing furnace is certified for installation either as a Direct Vent (2-pipe) or Conventional (1-pipe) appliance. Direct Vent appliances draw combustion air from the outdoors and vent combustion products back outside. Installation with air taken from around the furnace is often referred to as Conventional installation - i.e. only the vent (exhaust) pipe is provided.

Provisions must be made during the installation of this furnace that provide an adequate supply of fresh air for combustion. The combustion air from the outside needs to be clear of chemicals that can cause corrosion. The inlet pipe should not be placed near corrosive chemicals such as those listed on page 5.

Another important consideration when selecting one or two pipe installation is the quality of the Indoor air which can sometimes be contaminated with various household chemicals. These chemicals can cause severe corrosion in the furnace combustion system. A 2-pipe installation has the additional advantage that it isolates the system from the effects of negative pressure in the house.

CAUTION:

Exhaust fans, clothes dryers, fireplaces and other appliances that force air from the house to the outdoors can create a negative pressure inside the house, resulting in improper furnace operation or unsafe conditions such as flame roll out. It is imperative that sufficient air exchange with the outdoors is provided to prevent depressurization. Additional information about how to test for negative pressure problems can be found in the NFGC.

Air openings on top of the furnace and openings in closet doors or walls must never be restricted. If the furnace is operated without adequate air for combustion, the flame roll-out switch will open, turning off the gas supply to the

burners. **NOTE:** This safety device is a manually reset switch. **DO NOT** install jumper wires across these switches to defeat their function or reset a switch without identifying and correcting the fault condition. If a switch must be replaced, use only the correct sized part specified in the Replacement Parts List provided online.

Direct Vent Furnaces

Direct Vent (2-pipe) furnaces draw combustion air directly from the outdoors and then vent the combustion products back outside, isolating the entire system from the indoor space. It is important to make sure that the whole system is sealed and clearances to combustibles are maintained regardless of the installation being in a confined or unconfined space.

Conventional Furnaces - Confined Spaces

A confined space is an area with volume less than 50 cubic feet per 1,000 Btuh of the combined input rates of all appliances drawing combustion air from that space. Furnace closets, small equipment rooms and garages are confined spaces. Furnaces installed in a confined space which supply heated air to areas outside the space must draw return air from outside the space and must have the return air ducts tightly sealed to the furnace. Ducts must have cross-sectional area at least as large as the free area of their respective openings to the furnace space. Attics or crawl spaces must connect freely with the outdoors if they are the source of air for combustion and ventilation.

The required sizing of these openings is determined by whether inside or outside air is used to support combustion, the method by which the air is brought to the space, and by the total input rate of all appliances in the space. In all cases, the minimum dimension of any combustion air opening is 3 inches.

Air From Inside

If combustion air is taken from the heated space, the two openings must each have a free area of at least one square inch per 1,000 Btuh of total input of all appliances in the confined space, but **not less than** 100 square inches of free area (Figure 1, page 9). See example.

Example:

If the combined input rate of all appliances is less than or equal to 100,000 Btuh, each opening must have a free area of at least 100 square inches. If the combined input rate of all appliances is 120,000 Btuh, each opening must have a free area of at least 120 square inches.

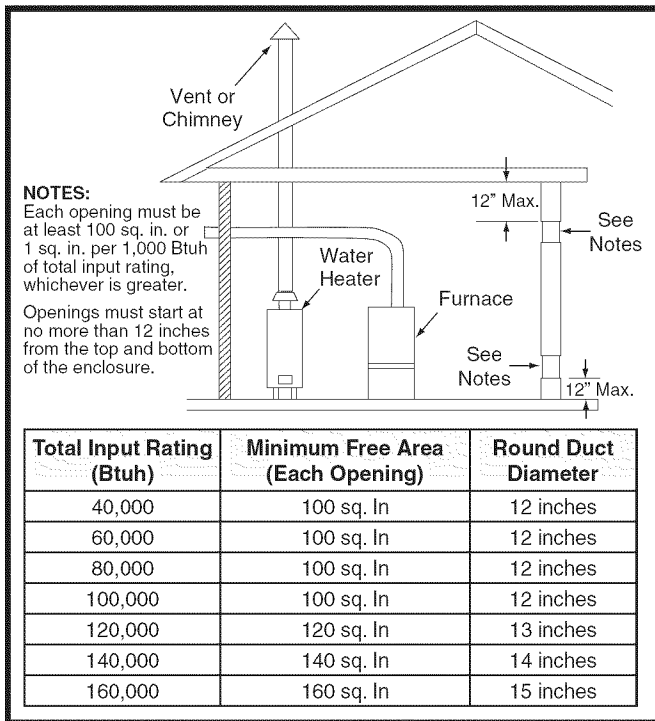

Figure 1. Combustion Air Drawn from Inside

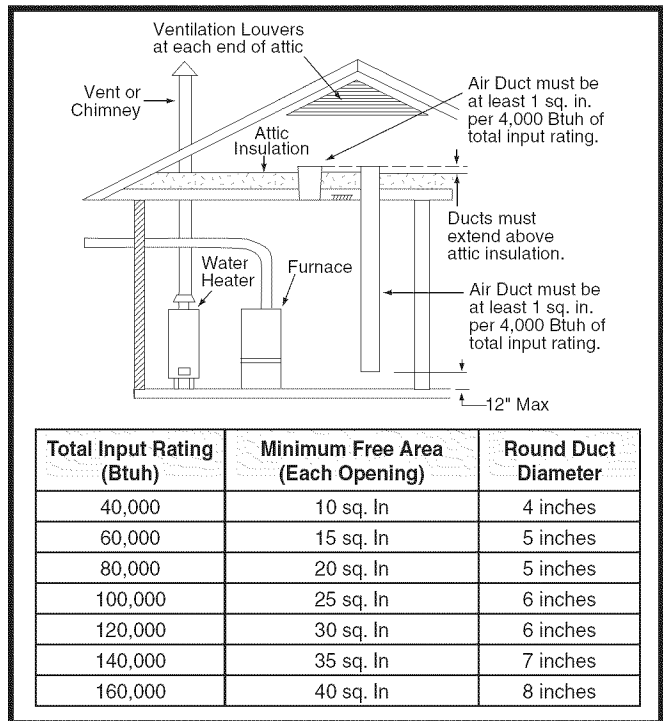

Figure 3. Combustion Air Drawn from Outside Through Vertical Ducts

Outdoor Air from a Crawl Space or Vented Attic

When the openings can freely exchange air with the outdoors, each opening shall have a minimum free area of 1 square inch per 4,000 Btuh of total appliance input. The openings shall exchange directly, or by ducts, with the outdoor spaces (crawl or attic) that freely exchange with the outdoors (Figure 2).

Outdoor Air Using Vertical Ducts

If combustion air is taken from outdoors through vertical ducts, the openings and ducts must have a minimum free area of one square inch per 4,000 Btuh of total appliance input (Figure 3).

Outdoor Air Using Horizontal Ducts

If combustion air is taken from outdoors through horizontal ducts, the openings and ducts must have a minimum free area of one square inch per 2,000 Btuh of total appliance input (Figure 4). Ducts must have cross-sectional area at least as large as the free area of their respective openings to the furnace space.

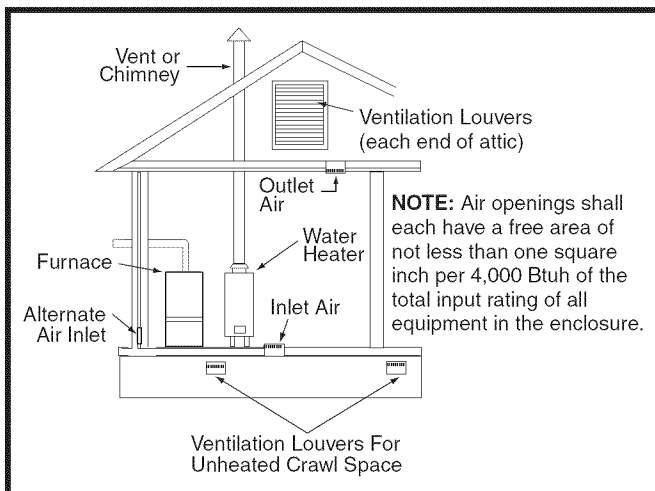

Figure 2. Combustion Air Drawn from a Crawl Space or Vented Attic

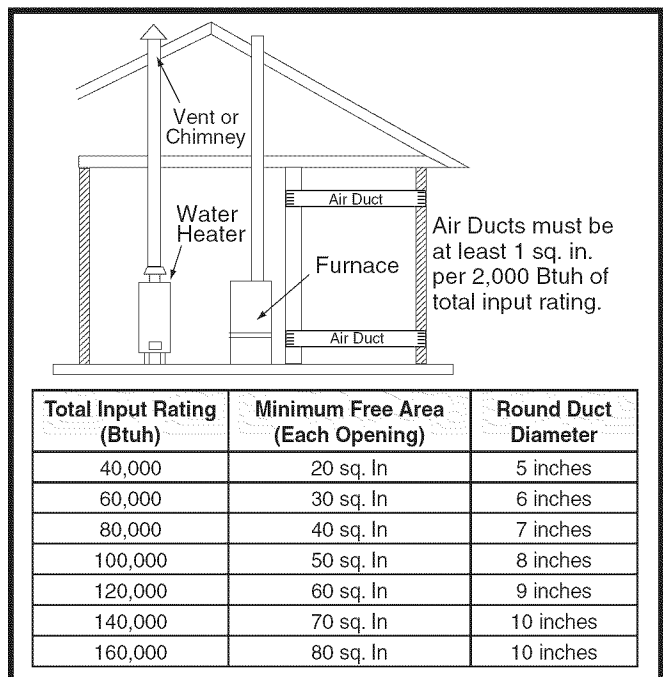

Figure 4. Combustion Air Drawn from Outside Through Horizontal Ducts

Air Directly Through An Exterior Wall

If combustion air is provided directly through an exterior wall, the two openings must each have free area of at least one square inch per 4,000 Btuh of total appliance input (Figure 5).

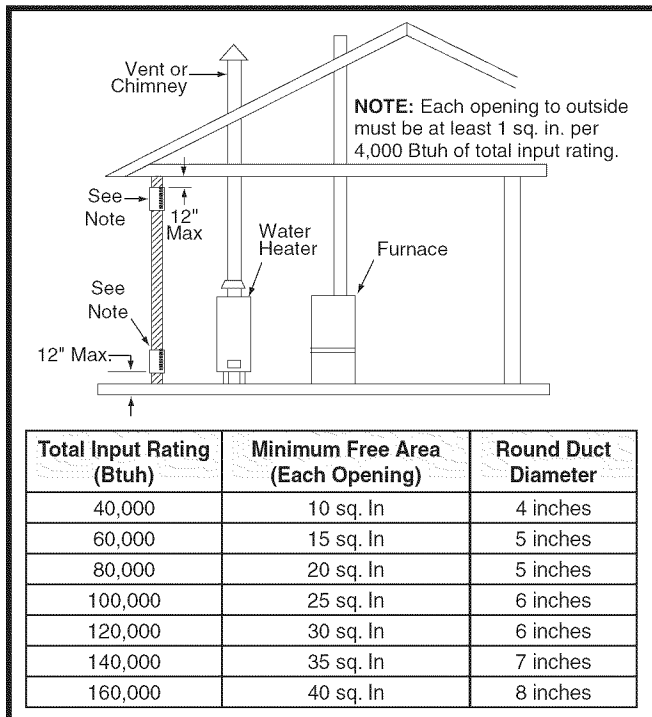

Figure 5. Combustion Air Drawn from Outside Through an Exterior Wall

Alternate Method of Providing Air from Outside:

If acceptable under local Codes, it is permitted to provide outside air using one opening (See NFGC). Generally, confined spaces must have two openings in the space for combustion air. One opening must be within 12 inches of the ceiling, and the other must be within 12 inches of the floor. However, an alternative method recently adopted by the NFGC uses one opening within 12 inches of the top of the space. This method may be used if it is acceptable to the local codes.

The following conditions must be met:

1. The opening must start within 12" of the top of the structure and connect with the out of doors through vertical or horizontal ducts or be ducted to a crawl or attic space that connects with the out of doors.
2. The opening must have a minimum free area of 1 sq. in. per 3,000 Btu per hour of the total input rating of all equipment located in the enclosure.
3. The free area must not be less than the sum of all the areas of the vent connectors in the enclosure.

Conventional Furnaces - Unconfined Spaces

An unconfined space is an area including all rooms not separated by doors with a volume greater than 50 cubic feet per 1,000 Btuh of the combined input rates of all appliances which draw combustion air from that space.

In general, a furnace installed in an unconfined space will not require outside air for combustion. However, in homes built for energy efficiency (low air change rates), it may be necessary to provide outside air to ensure adequate combustion and venting, even though the furnace is located in an unconfined space. See example.

Example:

A space with a water heater rated at 45,000 Btuh input and a furnace rated at 75,000 Btuh requires a volume of 6,000 cubic feet [$50 \times (45 + 75) = 6,000$] to be considered unconfined. If the space has an 8 foot ceiling, the floor area of the space must be 750 square feet ($6,000 / 8 = 750$).

Category IV Venting

This furnace is classified as a "Category IV" appliance, which requires special venting materials and installation procedures. This section specifies installation requirements for Conventional (1-pipe) and Direct Vent (2-pipe) piping.

! WARNING:

Upon completion of the furnace installation, carefully inspect the entire flue system both inside and outside the furnace to assure it is properly sealed. Leaks in the flue system can result in serious personal injury or death due to exposure of flue products, including carbon monoxide.

- This furnace must be vented in compliance with the current revision of the National Fuel Gas Code (ANSI-Z223.1/NFPA54) and the instructions provided below. **Consult local codes for special requirements.**
- In Canada, venting shall conform to the requirements of the current (CAN/CGA B149.1 or .2) installation codes. **Consult local codes for special requirements.**

! WARNING:

This furnace must not be vented with other appliances, even if that appliance is of the condensing type. This includes water heaters of any efficiency. Common venting can result in severe corrosion of other appliances or their venting and can allow combustion gases to escape through such appliances or vents. Do not vent the furnace to a fireplace chimney or building chase.

For 1- pipe installations, install vent piping as described in this section and provide air for combustion and ventilation according to pages 8 - 10. Table 2 contains the length of vent and combustion air piping for either type of installation.

Category IV appliances operate with positive vent pressure and therefore require vent systems which are thoroughly sealed. They also produce liquid condensate, which is slightly acidic and can cause severe corrosion of ordinary venting materials. Furnace operation can be adversely affected by restrictive vent and combustion air piping.

The inducer assembly on this furnace can be rotated to vent the flue products out of the top, left or right side. This increases the flexibility of which direction the vent pipe can exit the furnace.

Vent Pipe Material

Vent and combustion air pipe and fittings must be one of the following materials in the list and must conform to the indicated ANSI/ASTM standards. Cement must conform to ASTM Standard D2564 for PVC and Standard D2235 for ABS. PVC primer must meet standard ASTM F656. When joining PVC piping to ABS, use PVC solvent cement. (See procedure specified in ASTM Standard D3138).

<u>Materials</u>	<u>Standards</u>
Schedule 40PVC	D1785
PVC-DWV	D2665
SDR-21 & SDR-26.....	D2241
ABS-DWV	D2661
Schedule 40 ABS	F628
Foam/Cellular Core PVC	F891

In Canada, all plastic vent pipes and fittings including any cement, cleaners, or primers must be certified as a system to ULC S636. However this requirement does not apply to the finish flanges or piping internal to the furnace.

Vent Pipe Length & Diameter

In order for the furnace to operate properly, the combustion air and vent piping must not be excessively restrictive.

- The venting system should be designed to have the minimum number of elbows or turns.
- All horizontal runs must slope upwards from the furnace at 1/4 inch minimum per running foot of vent.
- Transition to the final vent diameter should be done as close to the furnace outlet as practical.
- Always use the same size or a larger pipe for combustion air that is used for the exhaust vent.

Table 2 indicates the maximum allowable pipe length for a furnace of known input rate, when installed with piping of selected diameter and number of elbows. To use the table, the furnace input rate, the centerline length and the number of elbows on each pipe must be known.

When estimating the length of vent runs, consideration must be made to the effect of elbows and other fittings. This is conveniently handled using the idea of “equivalent length”. This means the fittings are assigned a linear length that accounts for the pressure drop they will cause. For example: a 2” diameter, long radius elbow is worth the equivalent of 2.5 feet of linear run. A 90 degree tee is worth 7 ft.

The equivalent lengths of tees and various elbows are listed in Table 2. Measure the linear length of your vent run

FURNACE MODELS (BTU)	FURNACE INSTALLATION	SINGLE VENT PIPE LENGTH (FT.) with 1 long radius elbow [†]		DUAL VENT PIPE LENGTH (FT.) with 1 long radius elbow on each pipe [†]	
		OUTLET 2” Diameter	OUTLET 3” Diameter	INLET / OUTLET 2” Diameter	INLET / OUTLET 3” Diameter
38,000	Upflow	50	70	60	80
54,000	Upflow	90	90	90	90
	Downflow	90	90	90	90
72,000	Upflow	90	90	90	90
	Downflow	90	90	90	90
90,000	Upflow	90	90	90	90
	Downflow	70	90	70	90
108,000	Upflow	N/A	90	N/A	90
120,000	Upflow	N/A	90	N/A	90
	Downflow	N/A	90	N/A	90

†NOTES:

- 1 Subtract 2.5 ft. for each additional 2 inch long radius elbow, 5 ft. for each additional 2 inch short radius elbow, 3.5 ft. for each additional 3 inch long radius elbow, and 7 ft. for each additional 3 inch short radius elbow. Subtract 5 ft for each 2” tee and 8 ft for each 3” tee.
2. Two 45 degree elbows are equivalent to one 90 degree elbow.
3. This table applies for elevations from sea level to 2,000 ft. For higher elevations, decrease pipe lengths by 8% per 1,000 ft of altitude.

Table 2. Vent Pipe Lengths

and then add in the equivalent length of each fitting. The total length, including the equivalent fitting lengths, must be less than the maximum length specified in the table.

Condensing furnace combustion products have very little buoyancy, so Table 2 is to be used without consideration of any vertical rise in the piping.

Vent Pipe Installation

CAUTION:

Combustion air must not be drawn from a corrosive atmosphere.

This furnace has been certified for installation with zero clearance between vent piping and combustible surfaces. However, it is good practice to allow space for convenience in installation and service.

- The quality of outdoor air must also be considered. Be sure that the combustion air intake is not located near a source of solvent fumes or other chemicals which can cause corrosion of the furnace combustion system. (See page 5 for a sample list of substances).
- Route piping as direct as possible between the furnace and the outdoors. Longer vent runs require larger diameters. Vent piping must be sloped upwards 1/4" per foot in the direction from the furnace to the terminal. This ensures that any condensate flows back to the condensate disposal system.
- If a Direct Vent (2-pipe) system is used, the combustion air intake and the vent exhaust must be located in the same atmospheric pressure zone. This means both pipes must exit the building through the same portion of exterior wall or roof as shown in Figure 33, page 42.
- Piping must be mechanically supported so that its weight does not bear on the furnace. Pipe supports must be installed a minimum of every five feet along the vent run to ensure no displacement after installation. Supports may be at shorter intervals if necessary to ensure that there are no sagging sections that can trap condensate. It is recommended to install couplings along the vent pipe, on either side of the exterior wall (Figure 33). These couplings may be required by local code.
- If breakable connections are required in the combustion air inlet pipe (if present) and exhaust vent piping, then straight neoprene couplings for 2" or 3" piping with hose clamps can be used. These couplings can be ordered through your local furnace distributor. To install a coupling:
 1. Slide the rubber coupling over the end of the pipe that is attached to the furnace and secure it with one of the hose clamps.
 2. Slide the other end of the rubber coupling onto the other pipe from the vent.
 3. Secure the coupling with the second hose clamp, ensuring that the connection is tight and leak free.

Outdoor Terminations - Horizontal Venting

- Vent and combustion air intake terminations shall be installed as shown in Figures 6 & 7 (page 13) and in accordance with these instructions:
- Vent termination clearances must be consistent with the NFGC, ANSI 2223.1/NFPA 54 and/or the CSA B149.1, Natural Gas and Propane Installation Code. Table 15 (page 41) lists the necessary distances from the vent termination to windows and building air intakes.
- Vent and combustion air intake terminations must be located to ensure proper furnace operation and conformance to applicable codes. A vent terminal must be located at least 3 feet above any forced air inlet located within 10 feet. This does not apply to the combustion air inlet of a direct vent (two pipe) appliance. In Canada, CSA B149.1 takes precedence over these instructions. See Table 15 (page 41).
- All minimum clearances (Figure 7) must be maintained to protect building materials from degradation by flue gases.
- For optimal performance, vent the furnace through a wall that experiences the least exposure to winter winds.
- The vent termination shall be located at least 3 ft. horizontally from any electric meter, gas meter, regulator and any relief equipment. These distances apply ONLY to U.S. installations. In Canada, CSA B149.1 takes precedence over these instructions.
- Do not install the vent terminal such that exhaust is directed into window wells, stairwells, under decks or into alcoves or similar recessed areas, and do not terminate above any public walkways.
- If venting horizontally, a side wall vent kit is available according to the pipe diameter size of the installation. For 2 inch pipe use side wall vent kit #904617, and for 3 inch pipe use kit #904347. **Please follow the instructions provided with the kit.**

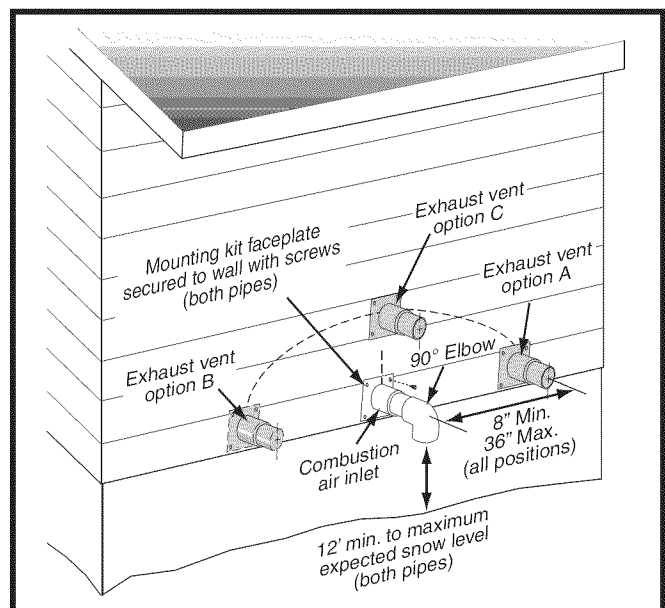

Figure 6. Inlet & Exhaust Pipe Clearances

- Concentric vent termination kits are available for use with these furnaces. For 2 Inch pipe use kit #904177 and for 3 inch pipe use kit # 904176. **Please follow the instructions provided with the kit.**
- When the vent pipe must exit an exterior wall close to the grade or expected snow level where it is not possible to obtain clearances shown in Figure 6, a riser may be provided as shown in Figure 8. Insulation is required to prevent freezing of this section of pipe. See Table 3 for vent freezing protection.

Outdoor Terminations - Vertical Venting

Termination spacing requirements from the roof and from each other are shown in Figure 9. The roof penetration must be properly flashed and waterproofed with a plumbing roof boot or equivalent flashing. Vent and combustion air piping may be installed in an existing chimney which is not in use provided that:

- Both the exhaust vent and air intake run the length of the chimney.

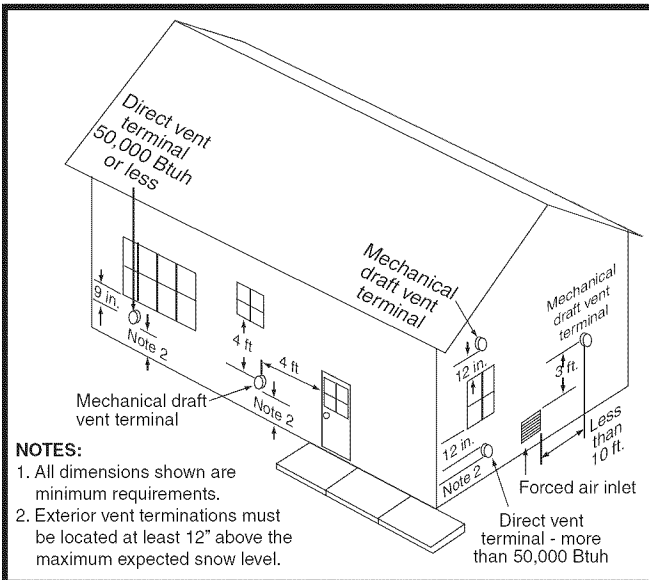

Figure 7. Vent Locations

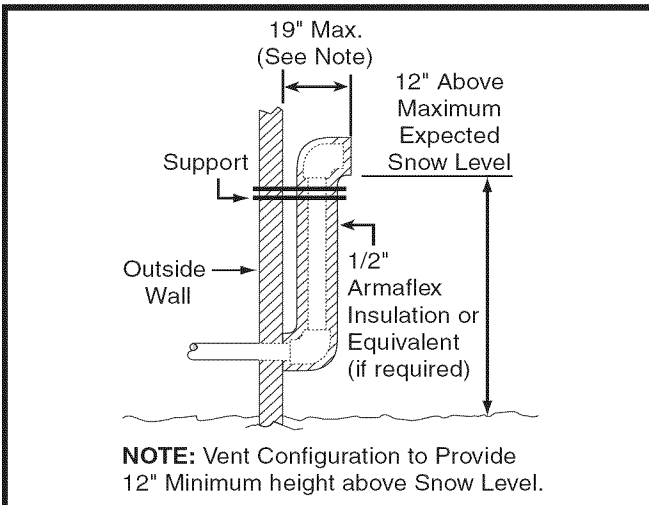

Figure 8. Alternate Horizontal Vent Installation

- The top of the chimney is sealed and weatherproofed.
- The termination clearances shown in Figure 9 are maintained.
- No other gas fired or fuel-burning equipment is vented through the chimney.

Vent Freezing Protection

CAUTION:

When the vent pipe is exposed to temperatures below freezing (i.e., when it passes through unheated spaces, chimneys, etc.) the pipe must be insulated with 1/2 inch thick sponge rubber insulation, Armaflex-type insulation or equivalent. Insulating pipe is important to avoid condensate icing.

- Table 3 lists the maximum length of flue pipe that can travel through an unconditioned space or an exterior space. The total vent length must not exceed the lengths noted in the Table. For Canadian installations, please refer to the Canadian Installation Code (CAN/CGA-B149.1 or 2) and/or local codes.
- For extremely cold climates or for conditions of short furnace cycles (i.e. set back thermostat conditions) the last 18 inches of vent pipe can be reduced. It is acceptable to reduce from 3" to 2-1/2", 3" to 2", or 2" to 1-1/2" if the total vent length is at least 15 feet in length, and the vent length is within the parameters specified in Table 2 (page 11). The restriction should be counted as

Winter Design Temperature	Maximum Flue Pipe Length (FEET) in Unconditioned & Exterior Spaces	
	Without Insulation	With Insulation*
20	45	70
0	20	70
-20	10	60

*NOTE: Insulation thickness greater than 3/8 inch, based on an R value of 3.5 (ft x F x hr) / (BTU x in.)

Table 3. Vent Protection

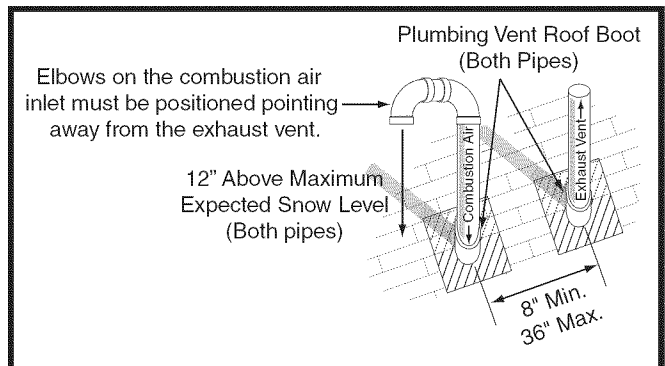

Figure 9. Vertical Vent Termination

3 equivalent feet. Smaller vent pipes are less susceptible to freezing, but must not be excessively restrictive. The length of the 2 inch pipe must not be longer than 18 inches.

- If furnace is installed horizontally, make sure the drainage port on the in-line drain assembly is pointed downward to ensure proper drainage of condensate. See Figures 35 & 36 (pages 44 & 45).
- To prevent debris or creatures from entering the combustion system, a protective screen may be installed over the combustion air intake opening. The screens hole size must be large enough to prevent air restriction.

Existing Installations

When an existing furnace is removed from a vent system serving other appliances, the existing vent system may not be sized properly to vent the remaining appliances (For example: water heater). An improperly sized venting system can result in the formation of condensate, leakage, or spillage. The existing vent system should be checked to make sure it is in compliance with NFPA and must be brought into compliance before installing the furnace.

NOTE: If replacing an existing furnace, it is possible you will encounter an existing plastic venting system that is subject to a Consumer Product Safety Commission recall. The pipes involved in the recall are High Temperature Plastic Vent (HTPV). **If your venting system contains these pipes DO NOT reuse this venting system!** This recall does not apply to other plastic vent pipes, such as white PVC or CPVC. Check for details on the CPSC website or call their toll-free number (800) 758-3688.

Condensate Disposal

The method for disposing of condensate varies according to local codes. Consult your local code or authority having jurisdiction. Neutralizer kit P/N 902377 is available for use with this furnace. **Please follow the instructions provided with the kit.**

This furnace has multiple options for positioning the vent pipe as described in the section, Vent and Inducer Assembly Options. Each of the condensate drain lines must be J-trapped using field supplied parts. After the condensate lines are J-trapped, they may be combined together when routed to the drain.

CIRCULATING AIR REQUIREMENTS

WARNING:

Do not allow combustion products to enter the circulating air supply. Failure to prevent the circulation of combustion products into the living space can create potentially hazardous conditions including carbon monoxide poisoning that could result in personal injury or death.

All return ductwork must be secured to the furnace with sheet metal screws. For installations in confined spaces, all return ductwork must be adequately sealed. When return air is provided through the bottom of the furnace, the joint between the furnace and the return air plenum must be air tight.

The surface that the furnace is mounted on must provide sound physical support of the furnace with no gaps, cracks or sagging between the furnace and the floor or platform.

Return air and circulating air ductwork must not be connected to any other heat producing device such as a fireplace insert, stove, etc. This may result in fire, explosion, carbon monoxide poisoning, personal injury, or property damage.

Plenums & Air Ducts

- Plenums and air ducts must be installed in accordance with the Standard for the Installation of Air Conditioning and Ventilating Systems (NFPA No. 90A) or the Standard for the Installation of Warm Air Heating and Air Conditioning Systems (NFPA No. 90B).
- Tables 6 & 7 (pages 34 - 36) contain the maximum airflow and temperature rise data for each furnace input rate. If the maximum airflow is 1,600 CFM or more, it is recommended that two openings be used for return air on upflow furnaces. Downflow furnaces can only use one return opening.
- It is recommended that the outlet duct contain a removable access panel. The opening should be accessible when the furnace is installed in service and shall be of a size that smoke or reflected light may be observed inside the casing to indicate the presence of leaks in the heat exchanger. The cover for the opening shall be attached in a way that prevent leaks.
- If outside air is used as return air to the furnace for ventilation or to improve indoor air quality, the system must be designed so that the return air is not less than 60° F (15° C) during operation. If a combination of indoor and outdoor air is used, the ducts and damper system must be designed so that the return air supply to the

furnace is equal to the return air supply under normal, indoor return air applications.

- When a cooling system is installed which uses the furnace blower to provide airflow over the indoor coil, the coil must be installed downstream (on the outlet side) of the furnace or in parallel with the furnace.
- If a cooling system is installed in parallel with the furnace, a damper must be installed to prevent chilled air from entering the furnace and condensing on the heat exchanger. If a manually operated damper is installed, it must be designed so that operation of the furnace is prevented when the damper is in the cooling position and operation of the cooling system is prevented when the damper is in the heating position.
- It is good practice to seal all connections and joints with industrial grade sealing tape or liquid sealant. Requirements for sealing ductwork vary from region to region. Consult with local codes for requirements specific to your area.

Supply Air Connections

The supply air must be delivered to the heated space by duct(s) secured to the furnace casing, running full size and without interruption.

Upflow / Horizontal Furnaces

To attach the supply air duct to the furnace, bend the furnace flanges (Figure 31, page 33) upward 90° with a pair of wide duct pliers. Position the duct on top of the furnace and secure together with sheet metal screws. The screws must penetrate the sheet metal casing and furnace flange. Tape or seal all seams if required by local code.

Downflow Furnaces

To attach the supply air duct to the downflow furnace, position the furnace over the duct and secure together with sheet metal screws. The screws must penetrate the duct and furnace cabinet.

Return Air Connections

In applications where the supply ducts carry heated air to areas outside the space where the furnace is installed, the return air must be delivered to the furnace by duct(s) secured to the furnace casing, running full size and without interruption.

Upflow / Horizontal Furnaces

For upflow installations, the return air ductwork may be connected to the left side, right side, or bottom. The bottom panel (Figure 31) must be installed for left or right return air. **NOTE: Do not use the back of the furnace for return air.**

Side Return Installations

To attach the return air duct to the left or right side of the furnace, punch out the four knockouts (Figure 31) from the preferred side of the furnace. Using sharp metal cutters, cut an opening between all four knockouts to expose the blower assembly. Position the return air duct over

the opening in the side and secure together with sheet metal screws. The screws must penetrate the duct and furnace cabinet.

WARNING:

The solid base of the furnace must be in position when the furnace is installed with side return air ducts. Removal of all or part of the base could cause circulation of combustible products into the living space and create potentially hazardous conditions, including carbon monoxide poisoning that could result in personal injury or death.

Bottom Return Installations

The bottom panel (Figure 31) must be removed from the furnace for bottom return air. If bottom panel is installed, go to page 16 for removal instructions. Position the furnace over the return air duct and secure together with sheet metal screws. The screws must penetrate the duct and furnace cabinet.

Downflow Furnaces

To attach the return air duct to the furnace, bend the furnace flanges (Figure 31) upward 90° with a pair of wide duct pliers. Position the duct on top of the furnace and secure together with sheet metal screws. The screws must penetrate the sheet metal cabinet and furnace flange. Tape or seal all seams if required by local code.

Acoustical Treatments

Damping ducts, flexible vibration isolators, or pleated media-style filters on the return air inlet of the furnace may be used to reduce the transmission of equipment noise emanating from the furnace. These treatments can produce a quieter installation, particularly in the heated space. However, they can increase the pressure drop in the duct system. Care must be taken to maintain the proper maximum pressure rise across the furnace, temperature rise and flow rate. This may mean increasing the duct size and/or reducing the blower speed. These treatments must be constructed and installed in accordance with NFPA and SMACNA construction standards. Consult with local codes for special requirements. For best sound performance, install all the needed gaskets and grommets around penetrations into the furnace, such as for electrical wiring.

FURNACE INSTALLATION

*SC series gas furnaces offer a wide range of installation options, including installation in the upflow or horizontal positions with either right, left, or upflow return air. The *SL series gas furnaces may only be installed as a down flow application.

General Requirements

- The furnace must be leveled at installation and attached to a properly installed duct system. See Table 1 (page 6) for the required clearances needed to move the furnace to its installation point (hallways, doorways, stairs, etc).
- The furnace must be installed so that all electrical components are protected from water.
- The furnace must be installed upstream from a refrigeration system. (If applicable)
- The cabinet plug must always be used to close the hole in the side of the furnace when rotating the inducer.
- The furnace requires special venting materials and installation procedures. See pages 7 -14 for venting guidelines and specifications.

Upflow Installation

WARNING:

The furnace must not be installed directly on carpeting, tile, or any combustible material other than wood flooring.

Side Return Air Inlet

*SC series gas furnaces are shipped with the bottom panel installed. If the furnace is installed using both side return air inlets, the bottom panel must not be removed. If the bottom of the furnace is not being used as a return, leave the bottom panel in place. See Figure 31 (Page 33).

Bottom Return Air Inlet

If the *SC series gas furnace is installed using the bottom as a return air inlet and 1 side return, the bottom panel (Figure 31) must be removed. See Bottom Panel Removal on page 22.

Downflow Installation

WARNING:

The furnace must not be installed directly on carpeting, tile, or any combustible material other than wood flooring.

WARNING:

Failure to install the downflow sub-base kit may result in fire, property damage or personal injury.

To install the furnace on combustible flooring, a special sub-base is required. Downflow sub-base kits are factory supplied accessories and are listed according to the cabinet

letter of the furnace. For 'A' size cabinets use Sub-Base kit #902974 only. For 'B', 'C', and 'D' size cabinets use Kit #904911. **Please follow the instructions provided with the kit.**

A downflow sub-base kit is not necessary if the furnace is installed on a factory or site-built cased air conditioning coil. However, the plenum attached to the coil casing must be installed so that its surfaces are at least 1" from combustible construction.

Installation on a Concrete Slab

1. Create an opening in the floor according to the dimensions in Figure 10.
2. Position the plenum and the furnace as shown in Figure 11 (page 17).

Horizontal Installation

WARNING:

The furnace must not be installed directly on carpeting, tile, or any combustible material other than wood flooring.

The *SC series gas furnace can be installed horizontally (Figure 12) in an attic, basement, crawl space or alcove. It can also be suspended from a ceiling in a basement or utility room in either a right to left airflow or left to right airflow as shown in Figure 13 (page 17).

*SC series furnaces are shipped with the bottom panel installed. If the furnace is installed horizontally, remove the bottom panel from the furnace before attaching the duct system. See Bottom Panel Removal on page 22.

If installing the furnace in an attic, it is required that a drip pan be placed under the furnace. If the installation is on a combustible platform (Figure 12), it is recommended that the drip pan extend at least 12 inches past the top and front of the furnace.

If suspending the furnace from the ceiling, assemble a support frame (Figure 13) using slotted iron channel and

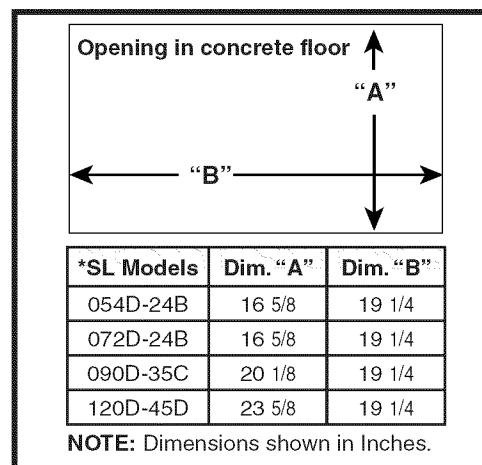

Figure 10. Cutout Dimensions

full threaded rod. Fasten the frame together with nuts, washers, and lockwashers. Secure the support frame to the rafters with lag bolts. The furnace can also be suspended using steel straps around each end of the furnace. The straps should be attached to the furnace with sheet metal screws and to the rafters with bolts.

It is recommended for further reduction of fire hazard that cement board or sheet metal be placed between the furnace and the combustible floor and extend 12 inches beyond the front of the door and top of the furnace.

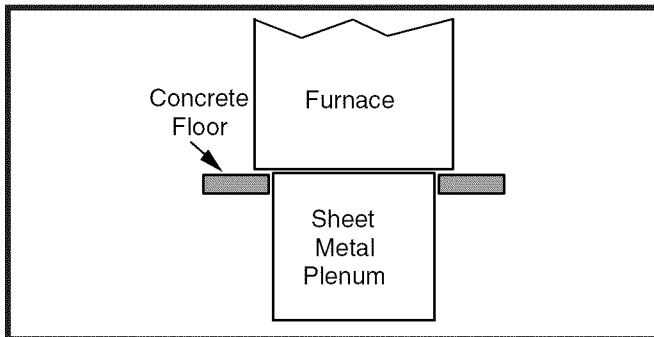

Figure 11. Furnace on a Concrete Slab

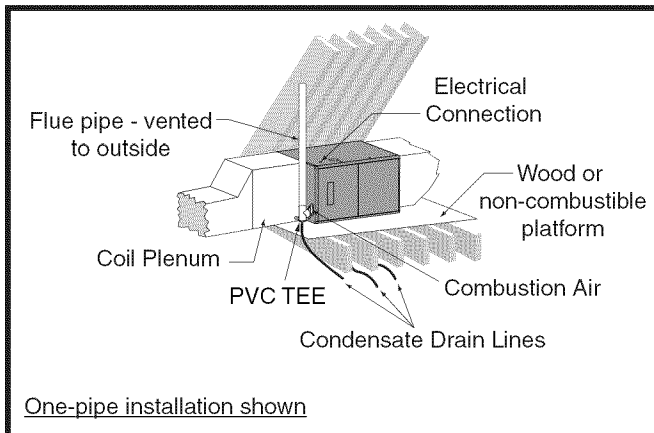

Figure 12. *SC Horizontal installation on a Platform

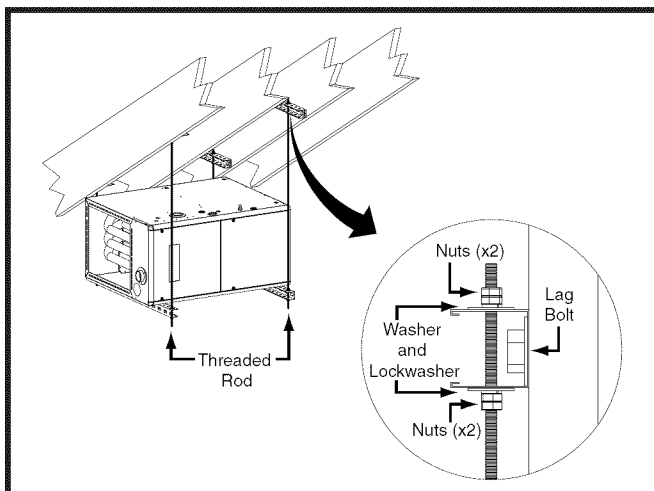

Figure 13. *SC Horizontally Suspended in Attic

Special Installation Instructions for SC038-23A Furnaces

If installing an SC038-23A furnace horizontally (with airflow going from left to right), the pressure switch will need to be moved to the side of the furnace that is not facing the ground (Figure 14). Moving the switch will make it easier to replace in the future.

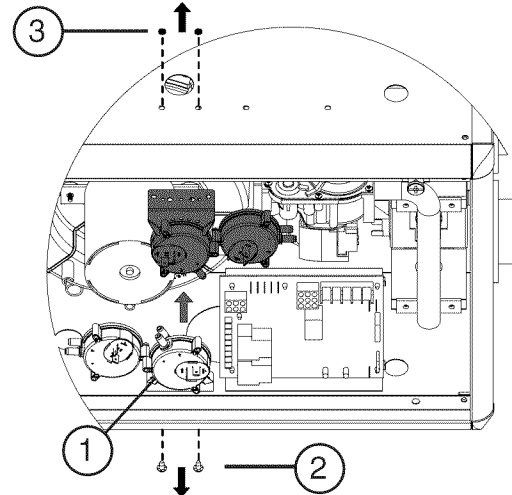

Figure 14. SC038-23A Pressure Switch

1. Shut off any electrical power to the furnace.
2. Label and disconnect the tubing and wires from the pressure switch (1).
3. Remove two screws (2) securing the pressure switch (1) to the side of the furnace.
4. Remove two 1/4" black plugs (3) on the opposite side of the cabinet that the pressure switch will be relocated to.
5. Position the pressure switch (1) in its new location and secure it in place using the same screws (2) removed in step 2
6. Insert the plugs (3) into the holes on the side that the pressure switch (1) was removed from.
7. Reconnect the tubing and wiring to the pressure switch (1) being careful that they will not fall into the burner box.

⚠ CAUTION:

It is extremely important that all wires and tubes be correctly reattached to the pressure switch(s). Failure to do so will result in malfunction or compromised safety functions of the furnace.

8. Check the furnace for proper operation as directed in Startup and Adjustments section. If the furnace shuts down during the pre-purge, the switch that measures pressure in the header needs to be checked for correct tubing connections.

Inducer & Venting Options

To increase installation flexibility, the inducer assembly can be rotated up to 3 different positions. Each variation has slightly different requirements with regard to condensate disposal and, in some cases, the need to seal the furnace cabinet. **IMPORTANT NOTE: The Inducer Assembly must never be positioned to vent downwards on horizontal installs.**

Before using Table 4, the number of pipes (1-pipe or 2-pipe) connected to the furnace must be known. Find the proper furnace style (upflow, horizontal, or downflow) and then the side that the pipes will exit from the furnace. Finally select the option that properly matches your installation type from Figures 34 - 37 (pages 43 - 46).

NOTE: It is important that Direct Vent (2-pipe) systems maintain an airtight flow path from the air inlet to the flue gas outlet. The furnace ships from the factory with two holes in the cabinet for the air inlet and flue gas outlet. In certain configurations, it is necessary to remove and relocate a plastic plug in the furnace cabinet. If changing the position of the air inlet and flue gas outlet, it is required that the previous hole be closed off with the plastic plug to maintain air tightness in the furnace. The hole locations for *SC and *SL furnaces are shown in Figure 31 (page 33).

Inducer Assembly Rotation

! WARNING:

Inducer rotation must be completed before the furnace is connected to gas and electric. If both utilities have been connected, follow the shutdown procedures printed on the furnace label and disconnect the electrical supply.

! CAUTION:

It is good practice to label all wires prior to disconnection. Wiring errors can cause improper and dangerous operation.

1. Disconnect the electrical harness (1) from the inducer assembly (2). See Figure 15.
2. Remove the inducer assembly ground wire (3) from the blower deck (4).
3. Remove three screws (5) securing the inducer assembly (2) to the header box (6).
4. Rotate the inducer assembly (2) to its new position.
5. Secure the inducer assembly (2) to the header box (6) by reinstalling the three screws (5). If the inducer assembly is rotated to the left or right side of the furnace, use the extra screw provided in the parts package.
6. Remove the cabinet plug (7) from side of furnace and reinstall in hole on opposite side of cabinet.

Conventional (1 Pipe)				
Vent	Upflow	Horizontal Right	Horizontal Left	Downflow
Up	Option 1	Option 7	Option 10	Option 15
Right	Option 2	Option 8	N/A	Option 16
Left	Option 3	N/A	Option 9	Option 17

Direct Vent (2-pipe)				
Vent	Upflow	Horizontal Right	Horizontal Left	Downflow
Up	Option 4	Option 12	Option 14	Option 18
Right	Option 5	Option 11	N/A	Option 19
Left	Option 6	N/A	Option 13	Option 20

Table 4. Vent & Inducer Blower Options

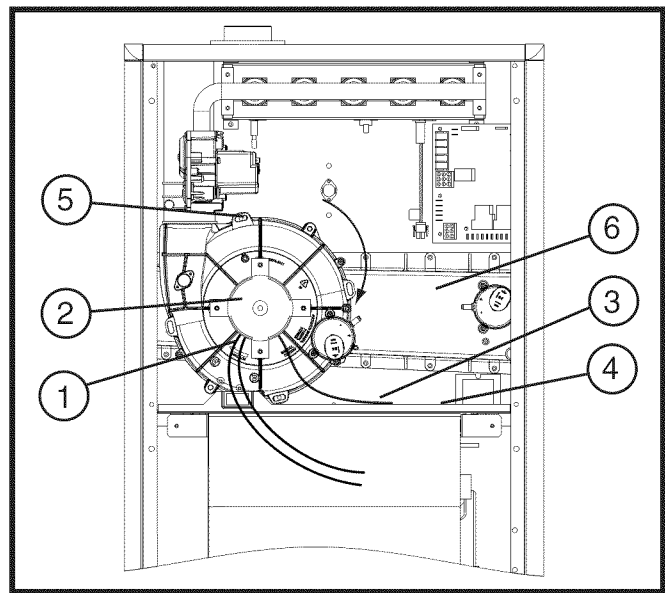

Figure 15. Inducer Assembly Rotation

7. Install in-line drain assembly and tubing.
8. If applicable, install the condensate drain lines as shown in (Figures 34 - 37).
9. Reconnect the electrical harness (1) to the inducer assembly (2).
10. Reconnect the inducer assembly ground wire (3) to the blower deck (4) or door.
11. Verify operation as detailed on the furnace label.

Pressure Switch Tubing

Figures 16 & 17 (page 19) display the proper routing of pressure switch tubing for *SC furnaces. All upflow / horizontal furnaces have two switches, one connected to the static tap on the inducer assembly and the other to the collector box. Downflow (*SL) furnaces require only one switch connected to the inducer's static tap as shown in Figure 18.

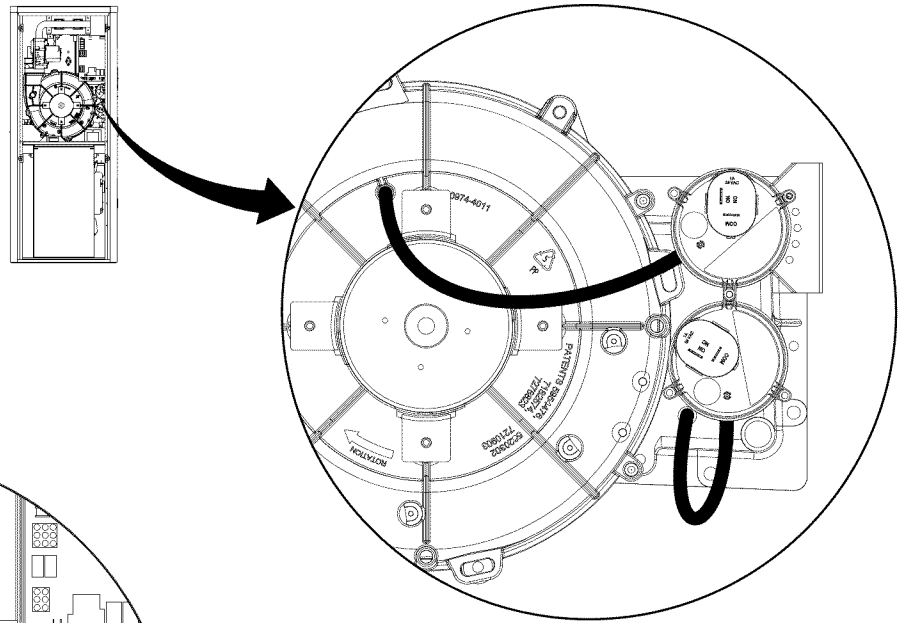

Figure 16. Pressure Switch Tubing for *SC038 Furnaces Only

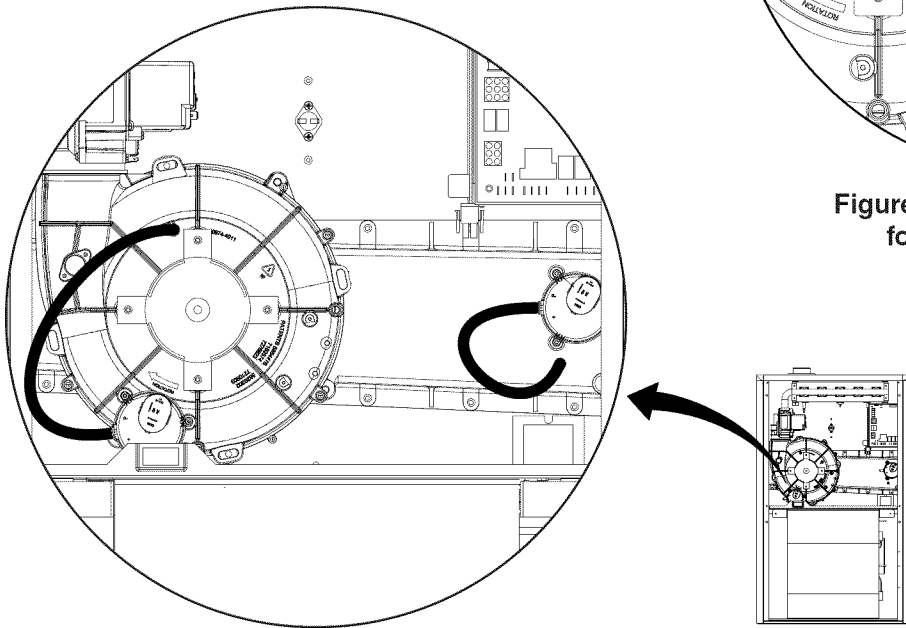

Figure 17. Pressure Switch Tubing for Upflow Furnaces (Models: *SC054, *SC072, *SC090, *SC108, & *SC120)

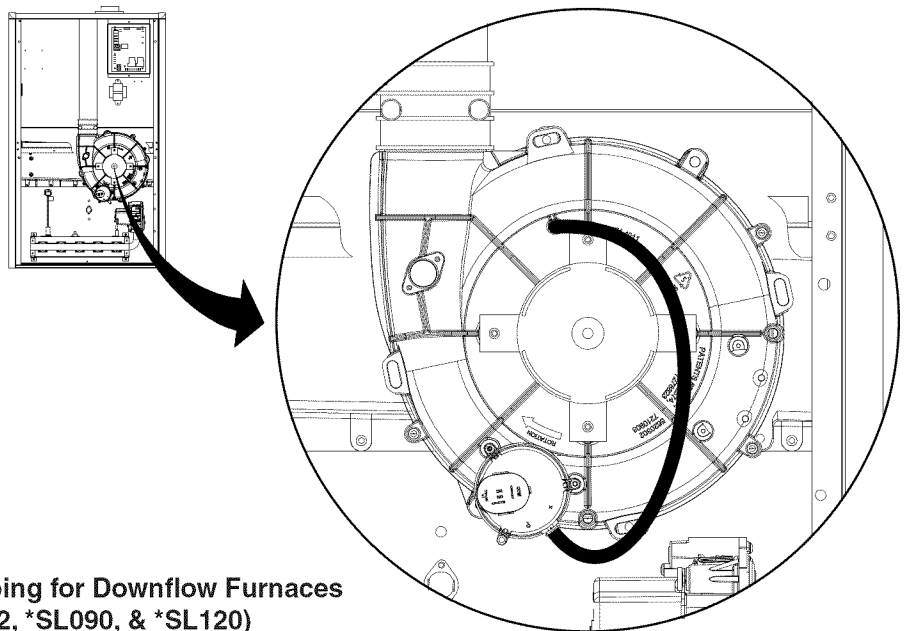

Figure 18. Pressure Switch Tubing for Downflow Furnaces (Models: *SL054, *SL072, *SL090, & *SL120)

Alternate Pressure Switch Location

In some inducer orientations, the inducer pressure switch may interfere with gas pipe installation. Determine the side of the cabinet the gas pipe will enter and see if the inducer pressure switch needs to be moved. If the pressure switch interferes with the gas pipe, use these instructions for relocating it to an alternate location:

1. Shut off any electrical power to the furnace.
2. Label and disconnect the tubing and wires from the pressure switch (Figure 19).
3. Remove two screws securing the pressure switch to the inducer housing.
4. Remove the pressure switch from the mounts on the inducer housing and relocate it to the other set of mounts 90° from previous location.
5. Secure the pressure switch with two screws.
6. Reconnect the tubes and wires to the pressure switch.

Accessories

The components below are included in the extra parts bag that is supplied with the purchase of your furnace. Depending on your particular installation, some of these components are optional and may not be used. Please refer to the descriptions and accompanying figures when installing these items.

Finish Flanges

The finish flanges must be installed to vent the combustion air pipe through the top of the furnace. **NOTE:** For proper installation it is important that the pipe and screw holes in the finish flanges, gasket, and cabinet are aligned. See Figure 20.

1. Position flange gasket over hole in the furnace cabinet.
2. Position finish flange on top of the flange gasket.
3. Secure flange and gasket to cabinet with three field supplied sheet metal screws.

Rubber Grommets

The 2 1/4" rubber grommet is used to seal the opening between the furnace cabinet and the 2" PVC vent pipe. The rubber grommet should be installed in the 3" hole prior to running the vent pipe out of cabinet. No sealants are required. See Figure 21.

The 7/8" rubber grommet is used to seal the opening between the furnace cabinet and the gas pipe. The rubber grommet should be installed in the 1 5/8" hole prior to running the gas pipe into the cabinet. No sealants are required.

The 3/4" rubber grommet is used if venting out the left side of the cabinet and the drain tube is routed through the blower deck. Remove the plastic plug from the hole and install the grommet before routing the drain tube.

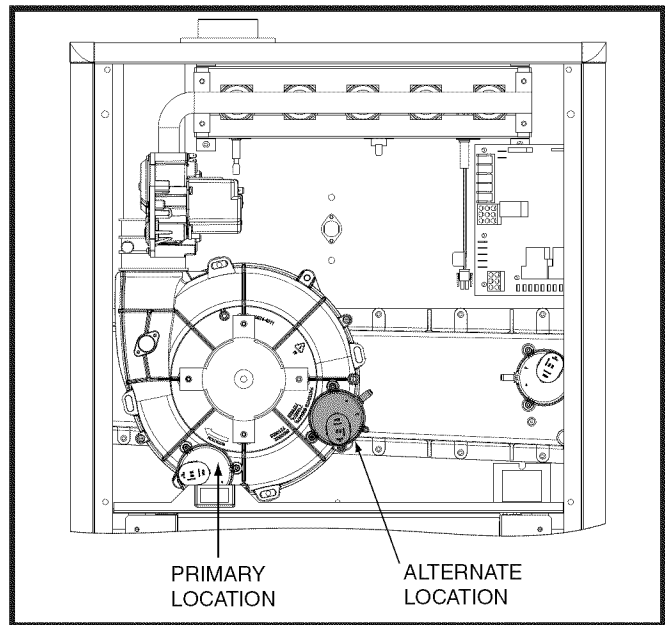

Figure 19. Alternate Pressure Switch Location

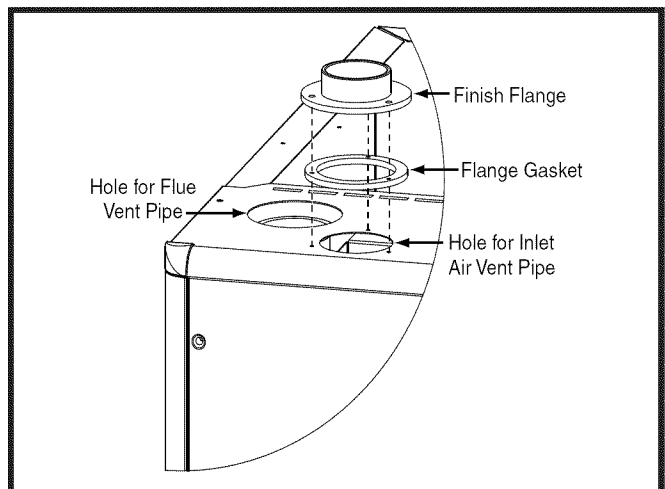

Figure 20. Finish Flanges

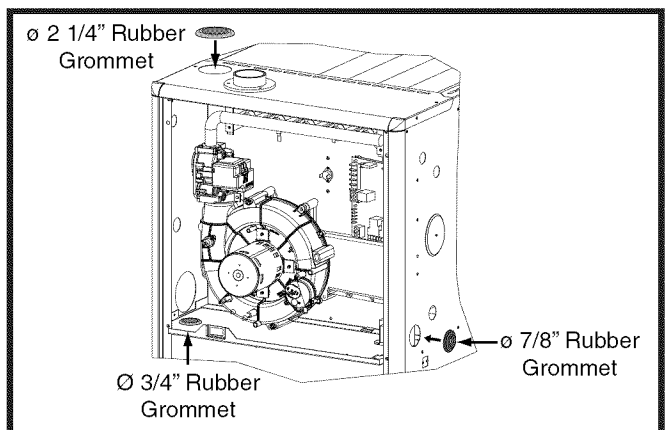

Figure 21. Rubber Grommets

PVC TEE, Reducer, & Hose Barbs

The 2" PVC tee, reducer, and hose barb are used when the inducer is rotated to vent out thru the left or right side of the furnace cabinet. See Figure 22 (page 20).

The 1/2" x 3/4" hose barb can be used to route the condensate drain to the outside of the cabinet. It must be installed from inside the cabinet with the threaded end inserted thru the 1 1/16" hole. The Condensate drain should be connected to the barbed end. Attach 1" PVC drain line to the threaded end. See Figure 31 (page 33) for hole location.

IMPORTANT NOTES:

- Before permanently installing these components, it is recommended you dry-fit them first to ensure proper fit and alignment with other vent pipes.
 - The 2" PVC pipe shown in Figure 22 is not provided in the extra parts bag.
1. Install the 1/2" x 1/2" hose barb on the 2" PVC reducer. **NOTE:** Do not overtighten! Use an adequate amount of Teflon tape on the threads. Do not use liquid sealants.
 2. Install the reducer on one end of the PVC tee. Use appropriate primer and cement to permanently bond the reducer and tee together.
 3. Install the tee on the 2" vent pipe that is extending out the side of the cabinet. Use appropriate primer and cement to permanently bond them together.
 4. Verify all connections and joints for tight fit and proper alignment with other vent pipes.

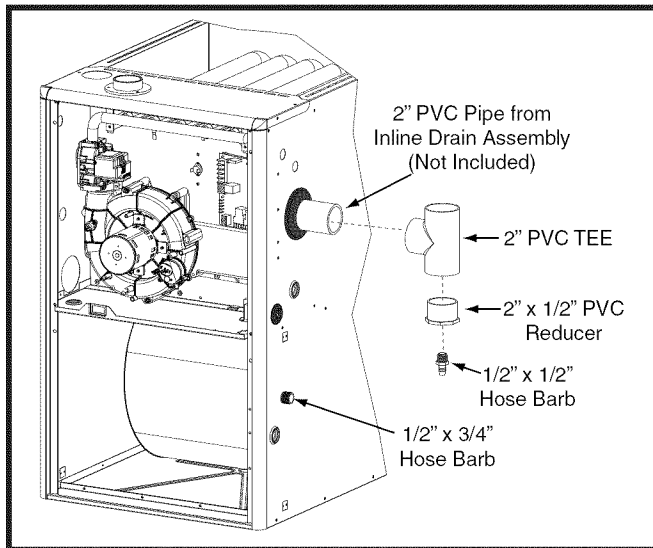

Figure 22. 2" PVC Tee, Reducer & Hose Barb

Optional PVC Pipe Installation

When running the 2" PVC pipe out through the top of the *SC upflow furnace, there may be possible clearance issues when transitioning the PVC pipe from 2" to 3":

- If the size of the PVC flue needs to be increased from 2" to 3", two, 2" x 45° PVC elbows may be used to achieve the clearances needed between the coil box and the 2" x 3" coupling. See Figure 23.
- Install the 2" x 3" coupling in the vertical run only. If the coupling is installed horizontally, it will allow water to build up inside the furnace and cause a lock out condition.
- To avoid the clearance issue, it is recommended that the furnace be vented through the left side or the right side of the cabinet.

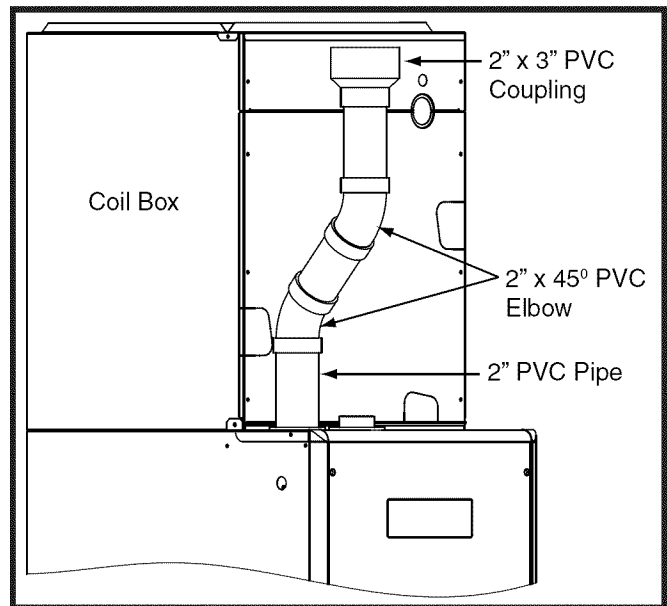

Figure 23. Optional PVC Pipe Installation

Condensate Drain Lines

The placement of the condensate drain lines will depend on the configuration selected in Table 4 (page 19). The drain lines can be routed out the left or right side of the furnace, but must maintain a downward slope to ensure proper condensate drainage. The J-trap may need to be rotated to the side that matches your setup in Figures 34 - 37 (pages 43 - 46). To rotate the J-trap, loosen the clamp on the drain tube, rotate the J-trap to either side, and retighten the clamp

Four general principles apply:

- Each condensate drain must be trapped separately using a J-Trap or field supplied loop.
- There must always be a drain attached to the collector at the outlet of the secondary heat exchanger.
- There must always be a drain at the outlet of the inducer assembly.

- There must always be a drain at the lowest point of the venting system.

Exceptions and clarifications to the general rules:

- In some cases, the lowest point in the vent system is where it connects to the inducer. In this case one drain at this location is sufficient. (Options 8, 10, 12, 14)
- If the vent exits the furnace horizontally, the vent may be turned vertically with a tee. **The drip leg formed by the tee must include a drain.** (Options 2,3,5,6,8,9,12,13,16,17,19, 20)
- In certain cases, it is permitted to drain the inducer back into the top drain of the collector. **This drain must not sag in the middle.** (Options 2, 5, 7, 11, 15, 16, 18 19)

IMPORTANT NOTE: If the furnace is installed in an area where temperatures fall below freezing, special precautions must be made for insulating condensate drain lines that drain to the outdoors. If condensate freezes in the lines, this will cause improper operation or damage to the furnace. It is recommended that all drain lines on the outside of the residence be wrapped with an industry approved insulation or material allowed by local code.

Bottom Panel Removal

The steps listed below describe how to remove the bottom panel from the furnace. See Figure 24.

1. Remove the door (1) from the blower compartment.
2. Disconnect the blower motor wiring harness (2) from the control board.
3. Remove two screws (3) securing the blower assembly (4) to the furnace.
4. Carefully pull the blower assembly (4) out thru the front of the furnace.
5. Remove all screws (5) securing bottom panel (6) to bottom of furnace and front brace (7).
6. Lift up and slide bottom panel (6) out through front of furnace.
7. Reinstall the blower assembly (4) in reverse order.

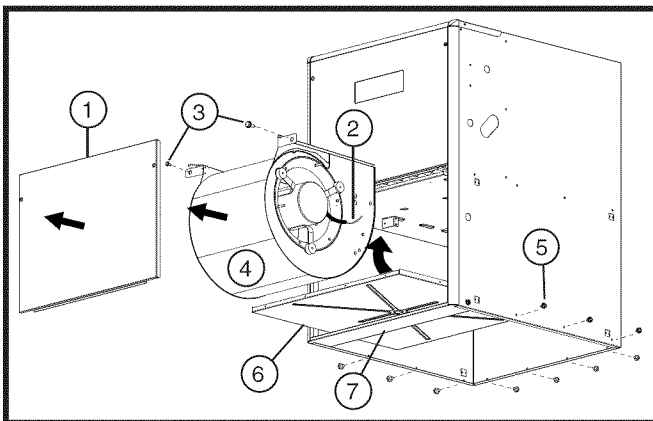

Figure 24. Bottom Panel Removal

Alternate Bottom Panel Removal

If the bottom panel cannot be removed using the previous instructions, the steps below are an alternate method for removing the bottom panel. See Figure 25.

1. Remove the door (1) from the blower compartment .
2. Remove all screws securing the bottom panel (2) to the front brace (3).
3. Remove two screws (4) securing the furnace cabinet to the blower deck (5).
4. Remove all screws (6) securing the furnace cabinet to the bottom panel (2).
5. Remove the screw (7) securing the bottom corner of the furnace cabinet to the front brace (3).
6. Carefully spread the bottom corner of the furnace cabinet outwards while sliding the bottom panel (2) out through the front of the furnace.
7. Reassemble the furnace in reverse order.

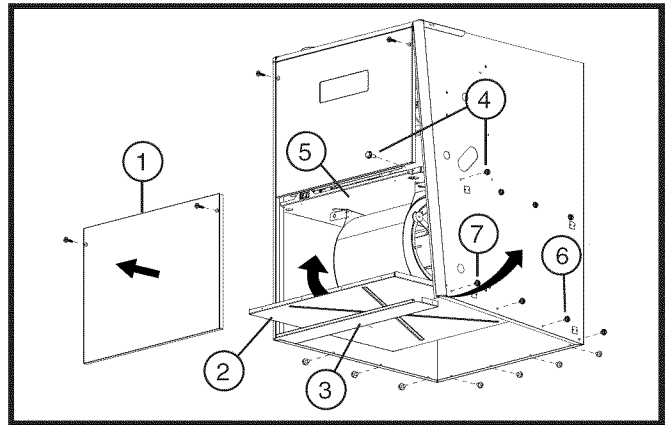

Figure 25. Alternate Removal Method

GAS SUPPLY & PIPING

WARNING:

FIRE OR EXPLOSION HAZARD

- Failure to follow safety warnings exactly could result in serious injury or property damage.
- Installation and service must be performed by a qualified installer, service agency or the gas supplier.
- Do not store or use gasoline or other flammable vapors and liquids in the vicinity of this or any other appliance.

WHAT TO DO IF YOU SMELL GAS

- Do not try to light any appliance.
- Do not touch any electrical switch; do not use any phone in your building.
- Leave the building immediately.
- Immediately call your gas supplier from a neighbor's phone. Follow the gas supplier's instructions.
- If you cannot reach your gas supplier, call the fire department.

- All gas piping must be installed in compliance with local codes and utility regulations. In the absence of local codes the gas line installation must comply with the latest edition of the National Fuel Gas Code (ANSI Z223.1) or (CAN/CGA B149.1 or .2) Installation Codes.
- Some local regulations require the installation of a manual main shut-off valve and ground joint union external to the furnace as shown in Figure 26 (page 25). The shut-off valve should be readily accessible for service and/or emergency use. Consult the local utility or gas supplier for additional requirements regarding placement of the manual main gas shut-off.
- Gas piping must never run in or through air ducts, chimneys, gas vents, or elevator shafts.
- Compounds used on threaded joints of gas piping must be resistant to the actions of LP propane gas.
- The main gas valve and main power disconnect to the furnace must be properly labeled by the installer in case emergency shutdown is required.
- Flexible gas connectors are not recommended for this type of furnace but may be used if allowed by local jurisdiction. Only new flexible connectors may be used. Do not use a connector which has previously serviced another gas appliance.
- A drip leg should be installed in the vertical pipe run to the unit (Figure 26).

Table 10 (page 38) lists gas flow capacities for standard pipe sizes as a function of length in typical applications based on nominal pressure drop in the line.

The furnace may be installed with either left or right side gas entry. When connecting the gas supply, provide clearance between the gas supply line and the entry hole in the furnace casing to avoid unwanted noise and/or damage to the furnace. Typical gas hookups are shown in Figure 26.

Leak Check

WARNING:

FIRE OR EXPLOSION HAZARD

Failure to follow safety warnings exactly could result in serious injury or property damage.

Never test for gas leaks with an open flame. Use a commercially available soap solution made specifically for the detection of leaks to check all connections. A fire or explosion may result causing property damage, personal injury or loss of life.

AVERTISSEMENT:

RISQUE D'INCENDIE OU D'EXPLOSION

- Le non-respect des avertissements de sécurité pourrait entraîner des blessures graves, la mort ou des dommages matériels.
- L'installation et l'entretien doivent être effectués par un installateur qualifié, un organisme de service ou le fournisseur de gazstaller, service agency or the gas supplier.
- Ne pas entreposer ni utiliser de l'essence ni d'autres vapeurs ou liquides inflammables dans le voisinage de cet appareil, ni de tout autre appareil.

QUE FAIRE S'IL Y A UNE ODEUR DE GAZ

- Ne pas tenter d'allumer aucun appareil.
- Ne toucher à aucun interrupteur électrique; n'utiliser aucun téléphone dans le bâtiment.
- Évacuer l'immeuble immédiatement.
- Appeler immédiatement le fournisseur de gaz en employant le téléphone d'un voisin. Respecter à la lettre les instructions du fournisseur de gaz.
- Si personne ne répond, appeler le service des incendies.



AVERTISSEMENT:

RISQUE D'INDENDIE OU D'EXPLOSION

Le non-respect des avertissements de sécurité pourrait d'entraîner des blessures graves, la mort ou des dommages matériels.

Ne jamais utiliser une flamme nue pour vérifier la présence des fuites de gaz. Pour la vérification de tous les joints, utiliser plutôt une solution savonneuse commerciale fabriquée spécifiquement pour la détection des fuites de gaz. Un incendie ou une explosion peut entraîner des dommages matériels, des blessures ou la mort.

After the gas piping to the furnace is complete, all connections must be tested for gas leaks. This includes pipe connections at the main gas valve, emergency shutoff valve and flexible gas connectors (if applicable). The soap and water solution can be applied on each joint or union using a small paintbrush. If any bubbling is observed, the connection is not sealed adequately and must be retightened. Repeat the tightening and soap check process until bubbling ceases.

IMPORTANT NOTE: When pressure testing gas supply lines at pressures greater than 1/2 psig (14 inch W.C.), the gas supply piping system must be disconnected from the furnace to prevent damage to the gas control valve. If the test pressure is less than or equal to 1/2 psig (14 inch W.C.), close the manual shut-off valve.

High Altitude Application

High altitude conversion with this furnace depends on the installation altitude and the heating value of the gas. Installation of this furnace at altitudes above 2,000 feet shall be in accordance with local codes, or in the absence of local codes, the National Fuel Gas Code, ANSI Z223.1/ NFPA 54 or National Standard of Canada, Natural Gas & Propane Installation Code CGA B149.1. Please consult your local code authority.



WARNING:

The reduction of input rating necessary for high altitude installation may only be accomplished with factory supplied orifices. Do not attempt to drill out orifices in the field. Improperly drilled orifices may cause fire, explosion, carbon monoxide poisoning, personal injury or death.

The furnaces are shipped from the factory with orifices and gas regulator settings for natural gas operation at sea level altitudes. At 2000 feet, the NFGC requires that this appliance be derated 4% for each 1000 feet of altitude. For example, the input needs to be reduced 8% at 2,000

feet, 12% at 3,000 feet, etc. This deration is in reference to the input rate and gas heating value at sea level.

To derate the furnace requires knowing the heating value of the gas at the installation site. Heating values at particular job sites vary for two reasons:

1. The chemical mixture of the gas varies across regions and is expressed as the "sea level heating value".
2. The heating value varies by altitude. For this reason, especially in high altitude areas, the local gas utility specifies the heating value at the residence's gas meter as the "local value".

For added flexibility, two tables have been provided for natural gas installations with high or low heating values at sea level. Tables 13 and 14 (page 40) contain the manifold pressure and orifice sizes to use at various altitudes. Table 13 (HIGH) is for natural gas installations with a heating value of more than 1,000 Btu per cubic foot and Table 14 (LOW) is for less than 1,000 Btu per cubic foot. To determine which table to use:

1. Consult the local utility for the local heating value at your installation site.
2. From Table 12 (page 39), find your local heating value as supplied by the utility company. Follow down the column and stop at your altitude level.
3. If your sea level heating value is HIGH, use Table 13 or if it's LOW, use Table 14. See example below.

Installation Example

Elevation: 5,000 feet
Type of Gas: Natural Gas
Local Heating Value of Gas: 750

From Table 12, find 750 and follow down the column, stop at the 5,000 feet row. The heating value listed is LOW. Table 14 will be used to determine orifice size and manifold pressure.

After changing the regulator pressure or the orifices, it is required that you measure the gas input rate. This may be accomplished in the usual way, by clocking the gas meter and using the local gas heating value. See Verifying and Adjusting the Input Rate section (page 29).

IMPORTANT NOTE: Observe the action of the burners to make sure there is no yellowing, lifting or flashback of the flame.

UPFLOW MODELS

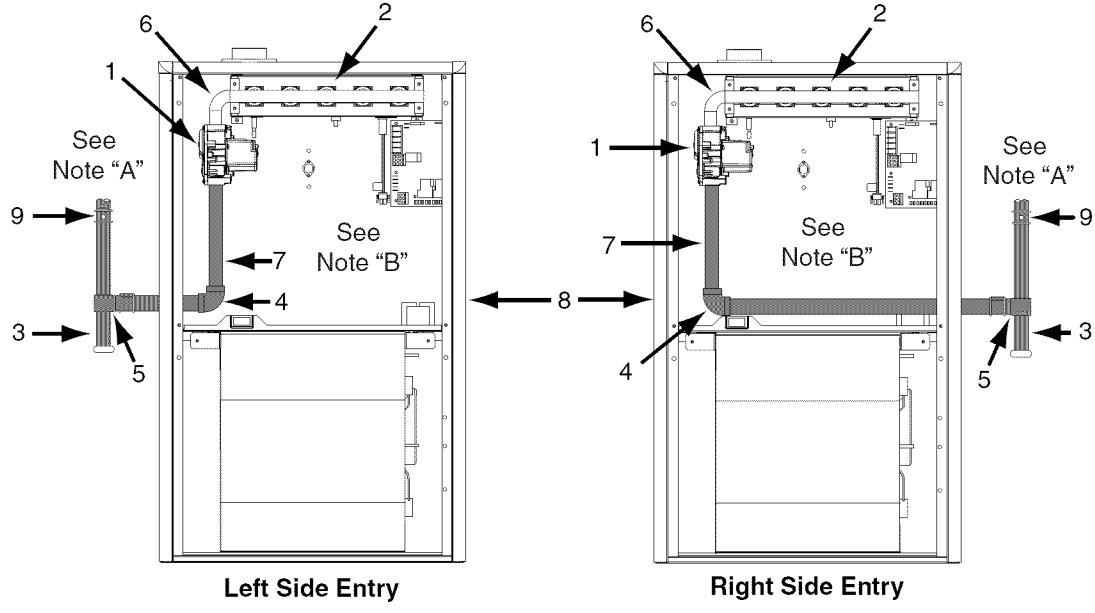

DOWNFLOW MODELS

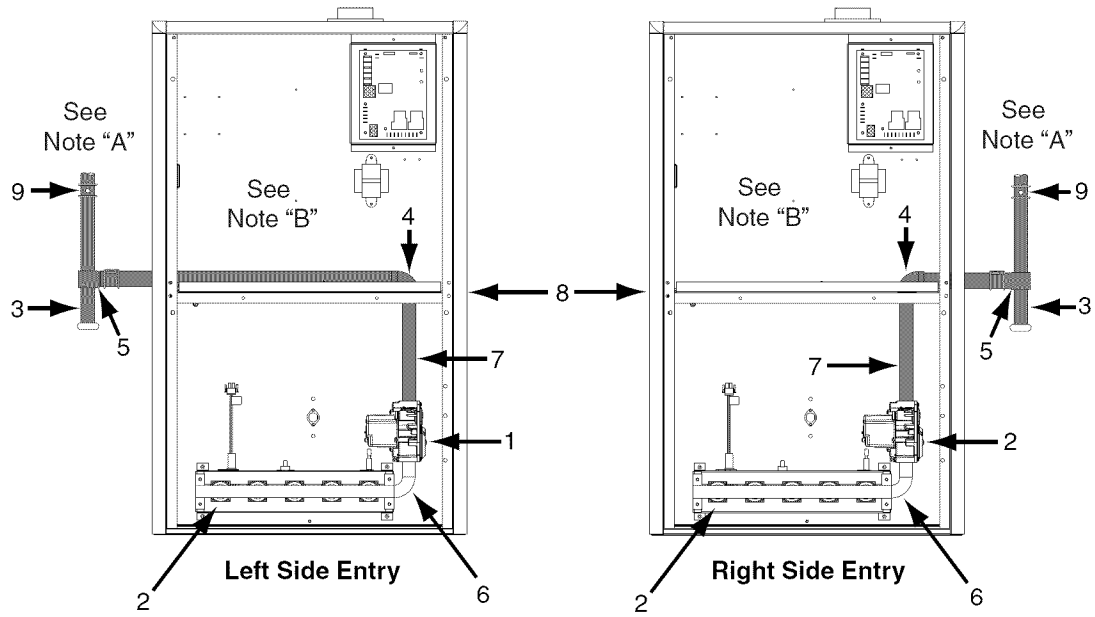

COMPONENTS:

- | | | |
|---|------------------------|----------------------|
| (1) Automatic Gas Valve
(w/ manual shut-off) | (2) Burner Assembly | (3) Dripleg |
| (4) Elbow | (5) Ground Joint Union | (6) Manifold |
| (7) Pipe Nipple (8 inch) | (8) Plug | (9) Shut - Off Valve |

NOTE A: Some utilities require Shut - Off Valve to be 4 - 5 feet above floor.
NOTE B: Inducer assembly omitted for clarity of pipe installation.

Figure 26. Typical Gas Connections

Conversion to LP / Propane

WARNING:

The furnace was shipped from the factory equipped to operate on natural gas. Conversion to LP / Propane gas must be performed by qualified service personnel using a factory supplied conversion kit. Failure to use the proper conversion kit can cause fire, explosion, property damage, carbon monoxide poisoning, personal injury, or death.

Conversion to LP / Propane is detailed in the installation instructions provided with the conversion kit. Generally, this will require the replacement of the burner orifices and the spring found under the cap screw on the pressure regulator. In the U.S. if installation is above 2,000 ft., refer to Table 11 (page 39) to determine the correct orifice size and regulator pressure. See example below.

Installation Example

Elevation: 5,000 feet
Type of Gas: Propane Gas
Input BTUH of Furnace: 72,000

From Table 11, find 5,000 and follow across the row, stop at the 72,000 feet column. The manifold pressure listed is 10.0 and the orifice size is 57.

When conversion is complete, verify the manifold pressure and input rate are correct as listed in the table. Approved conversion kits are listed below:

- The United States LP / Propane Gas Sea Level and High Altitude Conversion Kit (P/N 904914) is for LP / Propane conversion in the United States at altitudes between 2,000 ft. and 10,000 ft. above sea level. **Please follow the instructions provided with the kit.**
- The Canadian LP / Propane Gas Sea Level and High Altitude Conversion Kit (P/N 904915) is for LP / Propane conversions in Canada at altitudes between zero and 4,500 ft. above sea level. **Please follow the instructions provided with the kit.**

ELECTRICAL WIRING

WARNING:

ELECTRICAL SHOCK, FIRE OR EXPLOSION HAZARD

Failure to follow safety warnings exactly could result in serious injury or property damage.

Improper servicing could result in dangerous operation, serious injury, death or property damage.

- Before servicing, disconnect all electrical power to furnace.
- When servicing controls, label all wires prior to disconnecting. Reconnect wires correctly.
- Verify proper operation after servicing.”

AVERTISSEMENT:

RISQUE DE CHOC ÉLECTRIQUE, D'INCENDIE OU D'EXPLOSION

Le non-respect des avertissements de sécurité pourrait entraîner un fonctionnement dangereux de l'appareil, des blessures graves, la mort ou des dommages matériels.

Un entreteïn incorrect pourrait entraîner un fonctionnement dangereux de l'appareil, des blessures graves, la mort ou des dommages matériels

- Couper toute alimentation électrique au générateur d'air chaud avant de prodéder aux travaux d'entretein.
- Au moment de l'entretein des commandes, étiquetez tous les fils avant de les débrancher. S'assurer de les raccorder correctement.
- S'assurer que l'appareil fonctionne adéquatement après l'entretein.

- Electrical connections must be in compliance with all applicable local codes with the current revision of the National Electric Code (ANSI/NFPA 70).
- For Canadian installations the electrical connections and grounding shall comply with the current Canadian Electrical Code (CSA C22.1 and/or local codes).

IMPORTANT NOTE: If replacing any of the original wires supplied with the furnace, the replacement wire must be copper wiring and have a temperature rating of at least 105°F (40°C). For electrical specifications, refer to the furnace nameplate or Table 5 (page 26).

Line Voltage Wiring

It is recommended that the line voltage (115 VAC) to the furnace be supplied from a dedicated branch circuit containing the correct fuse or circuit breaker for the furnace as listed in Table 5.

IMPORTANT NOTES:

An electrical disconnect must be installed readily accessible from and located within sight of the furnace. See Figure 27 or the wiring diagram label inside of the control door. Any other wiring methods must be acceptable to authority having jurisdiction.

Proper line voltage polarity must be maintained in order for the control system to operate correctly. Verify the incoming neutral line is connected to the white wire and the incoming HOT line is connected

to the black wire. The furnace will not operate unless the polarity and ground are properly connected as shown in Figure 27.

Grounding

⚠ WARNING:

To minimize personal injury, the furnace cabinet must have an uninterrupted or unbroken electrical ground. The controls used in this furnace require an earth ground to operate properly. Acceptable methods include electrical wire or conduit approved for ground service. Do not use gas piping as an electrical ground!

Furnace Model Number *SC/*SL	Furnace Input (Btuh)	Cabinet Width (in.)	Nominal Electrical Supply	Maximum Operating Voltage	Minimum Operating Voltage	Maximum Furnace Amperes	Minimum Wire Gauge	Maximum Fuse or Circuit Breaker Amps*
038D-23A	38,000	14 ¼	115-60-1	127	103	6.6	14	15
054D-24B	54,000	17 ½	115-60-1	127	103	10.0	14	20
072D-24B	72,000	17 ½	115-60-1	127	103	10.0	14	20
072D-35C	72,000	21	115-60-1	127	103	9.3	14	15
090D-35C	90,000	21	115-60-1	127	103	15.6	14	30
108D-45D	108,000	24 ½	115-60-1	127	103	15.6	14	30
120D-45D	120,000	24 ½	115-60-1	127	103	15.6	12	30

Thermostat Wire Gauge	Recommended Thermostat Wire Length	
	2 - wire - Heating	4 or 5 wire - Cooling
24	55 ft.	25 ft.
22	90 ft.	45 ft.
20	140 ft.	70 ft.
18	225 ft.	110 ft.

* Time-delay fuses or circuit breakers are required.

Table 5. Wire Length & Voltage Specifications

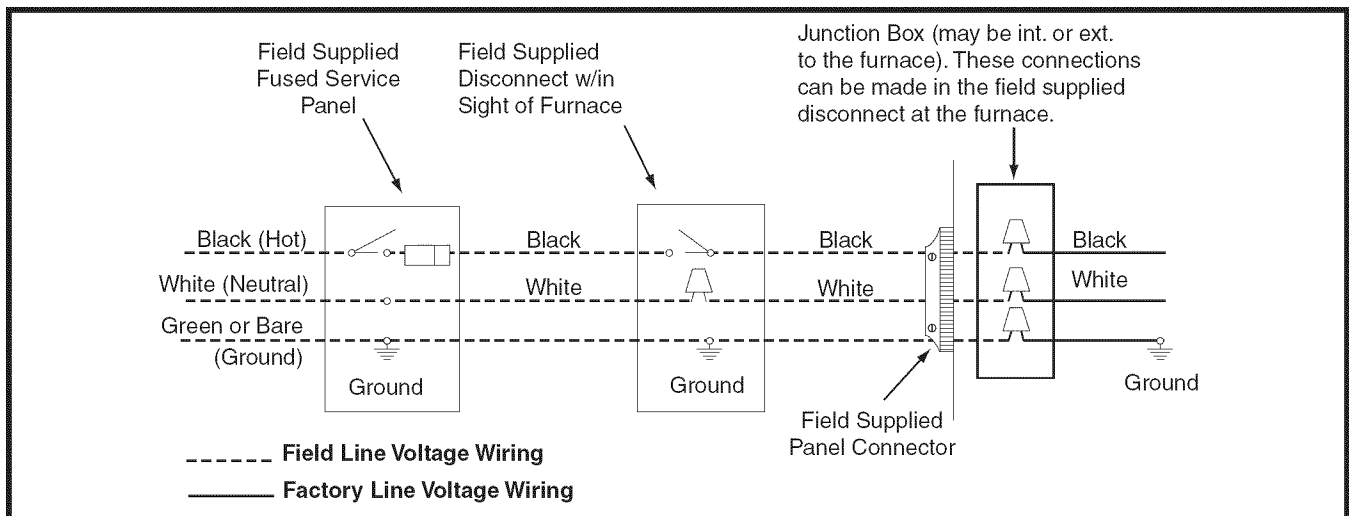

Figure 27. Line Voltage Field Wiring

Thermostat / Low Voltage Connections

- The furnace is designed to be controlled by a 24 VAC thermostat. The thermostat's wiring must comply with the current provisions of the NEC (ANSI/NFPA 70) and with applicable local codes having jurisdiction.
- The thermostat must be installed according to the instructions supplied by the thermostat manufacturer. Low voltage connections (24 VAC) from the thermostat are wired to the terminal strip on the integrated control in the furnace. Figure 28 contains the proper connections for heating only (two-wire) and heating/cooling (four-wire) applications. Recommended minimum wire gauge for thermostat wiring is shown in Table 5 (page 27).
- The thermostat should be mounted about 5 feet above the floor on an inside wall. DO NOT install the thermostat on an outside wall or any other location where its operation may be adversely affected by radiant heat from fireplaces, sunlight, or lighting fixtures, and convective heat from warm air registers or electrical appliances. Refer to the thermostat manufacturer's instruction sheet for detailed mounting information.
- The six pin terminal marked "Expansion Port" (Figure 28) is not used in the single stage furnace as shipped from the factory. It is used for the furnace control board to communicate to a fixed speed or variable speed high efficiency motor that may be optionally installed. Please contact your distributor for the proper upgrade motor kit.

Heat Anticipator

Set the heat anticipator according to the instructions supplied by the thermostat manufacturer. To determine the heat anticipator setting:

1. Add the current draw of the system components; or
2. Measure the current flow on the thermostat **R-W** circuit after the circulating blower motor has started.

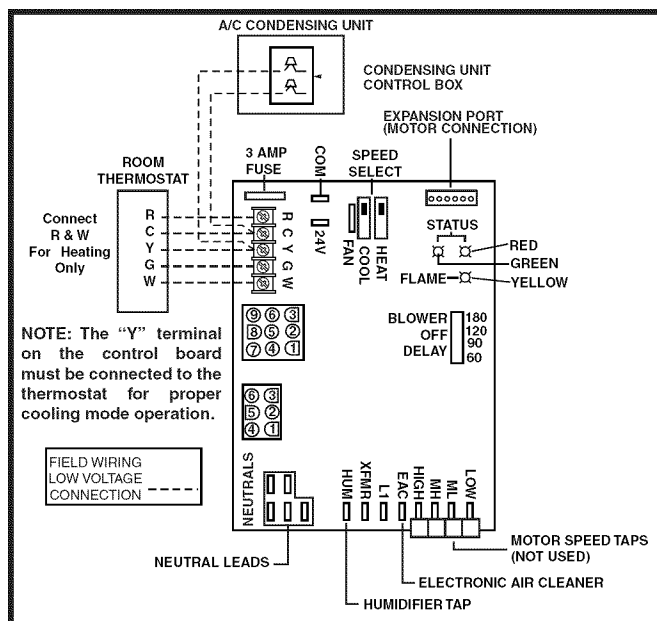

Figure 28. Low Voltage Field, Four-wire Heating/Cooling Applications

Twinning

Single stage furnaces are not supplied with a built-in twinning capability. Other valuable features and enhancements were made to the new control that made it necessary to remove the twinning capability. For twinning of single stage furnaces with PSC motors, a twinning kit (920919) is available for purchase. **Please follow the instructions provided with the kit.**

If both single stage furnaces are upgraded to the fixed speed iSEER™ blower, the twin terminal on the blower control boards (Figure 29) may be used to twin the single stage furnaces only if the following criteria are met:

- Both furnaces and motors must be the same size.
- Both motors must be on the same speed for cooling and heating.
- Both furnaces must have a common return duct and common supply plenum.
- Both furnaces must be the same phase and on the same leg of power.

IMPORTANT NOTE: Furnaces equipped with variable speed iSEER™ motors may not be twinned under any circumstances.

! WARNING:

When servicing either twinned furnace, power must be turned off on both furnaces. Failure to comply may result in improper operation leading to damage to the furnaces or personal injury!

For twinning of single stage furnaces equipped with fixed speed iSEER™ blowers, refer to Figure 29 and the following instructions:

1. Turn off all power to both furnaces.
2. Attach a wire between the two twin terminals on the twinning control boards. Use field supplied wire and two 3/16" wire terminals.

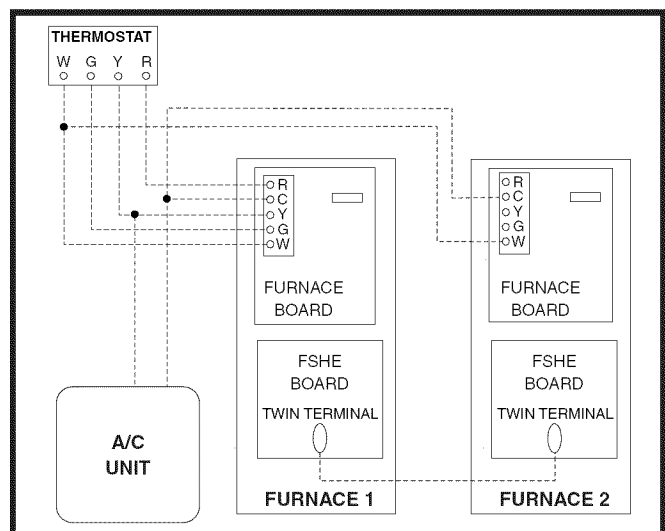

Figure 29. Single Stage Twinning

NOTE: One furnace can be used for one stage of heating and the other furnace can be used for the second stage of heating. The installer also has the choice of running one furnace only or both furnaces. In both cases the blowers will run at the same time and at the same speeds:

- **Single stage heating:** The **W** connection on each furnace must be connected together and then connected to the **W** connection of the thermostat. This will allow both furnaces to ignite at the same time for one stage heating.
 - **Two stage heating:** The **W** connection on one furnace must be connected to the **W1** connection of the thermostat. The **W** connection of the second furnace must be connected to the **W2** connection of the thermostat. This will allow one furnace to ignite for one stage of heating and the second furnace to ignite for the second stage of heating.
3. Refer to Figure 29 for the remaining thermostat connections. The **C** connection must be made between the twinned furnaces to ensure proper performance.

START-UP AND ADJUSTMENTS

Pre-Start Check List

- √ Verify the polarity of the connections are correct, the line voltage power leads are securely connected and the furnace is properly grounded.
- √ Verify the thermostat wires (**R, W, Y, & G**) are securely connected to the correct leads on the terminal strip of the circuit board.
- √ Verify the gas line service pressure does not exceed 10.0 inches of W.C., and is not less than 4.5 inches W.C. for natural gas. For LP gas the line service pressure must not exceed 14 in. W.C., and must not be less than 11.0 in. W.C.
- √ Verify the roll-out and manual reset switch is closed. If necessary, press the red button to reset a switch. **DO NOT install a jumper wire across a switch to defeat its function.** If a switch reopens on startup, **DO NOT** reset the switch without identifying and correcting the fault condition.
- √ Verify the blower door is in place, closing the door switch in the line voltage circuit.
- √ Verify the gas line has been purged and all connections are leak free.

Start-up Procedures

Do not perform these steps until all of the checks in the previous steps have been completed:

1. Set the thermostat to the lowest setting.
2. Turn off all electrical power to the furnace.
3. Follow the Operating Instructions on the label attached to the furnace.
4. Set the thermostat above room temperature and verify the Operating Sequence (page 30).
5. After 5 minutes of operation, set the thermostat below room temperature and verify steps 9 - 10 of the Operating Sequence.

Verifying & Adjusting Input Rate

The input rate must be verified for each installation to prevent over-firing of the furnace. **NOTE:** The input rate must not exceed the rate shown on the furnace rating plate. At altitudes above 2,000 feet, it must not exceed that on the rating plate less 4% for each 1,000 feet. To determine the exact input rate, perform the following procedures:

1. Shut off all other gas fired appliances.
2. Start the furnace and run it for at least 3 minutes.
3. Measure the time (in seconds) required for the gas meter to complete one revolution.
4. Convert the time per revolution to cubic feet of gas per hour using Table 9 (page 38).
5. Multiply the gas flow rate in cubic ft per hr by the heating value of the gas in Btu per cubic ft to obtain the input rate in Btuh. See example.

Example:

- Time for 1 revolution of a gas meter with a 1 cubic ft dial = 40 seconds.
- From Table 9 read 90 cubic ft gas per hr.
- Local heating value of the gas (obtained from gas supplier) = 1,040 Btu per cubic ft.
- Input rate = 1,040 x 90 = 93,600 Btuh.

6. The manifold pressure must be set to the appropriate value for each installation by a qualified installer, service agency or the gas supplier.

WARNING:

Do not attempt to drill the gas orifices. Use only factory supplied orifices. Improperly drilled orifices may cause fire, explosion, carbon monoxide poisoning, personal injury or death.

- a.) Obtain the manifold pressure setting required for this installation by referring to Table 11 (page 39) for Propane or Tables 13 or 14 (page 40) for Natural Gas.
- b.) Remove the regulator capscrew (Figure 30, page 30) from the INLET side of the regulator.
- c.) Slowly turn the adjustment screw inside the regulator to obtain the appropriate manifold pressure. **NOTE:** Turning the screw clockwise increases the pressure and turning the screw counter-clockwise decreases the pressure. To prevent backing the screw all the way out from the valve, turn the screw slowly.
- d.) Replace and tighten the regulator capscrew over the adjustment screw.

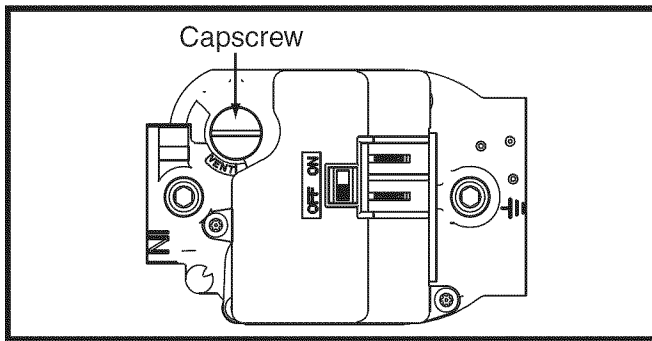

Figure 30. Regulator Capscrew

Verifying & Adjusting Temperature Rise

After installation of the furnace, confirm the temperature rise of the furnace is within the limits specified on the rating plate. Any temperature rise outside the specified limits could result in premature failure of the heat exchanger.

1. Place thermometers in the return and supply air stream as close to the furnace as possible. The thermometer on the supply air side must be shielded from direct radiation from the heat exchanger to avoid false readings.
2. Adjust all registers and duct dampers to the desired position and run the furnace for 10 to 15 minutes before taking any temperature readings. The temperature rise is the difference between the supply and return air temperatures.

For typical duct systems, the temperature rise will fall within the limits specified on the rating plate with the blower speed at the factory recommended setting. If the measured temperature rise is outside the specified limits, it may be necessary to change the speed of the blower.

NOTE: Lowering the blower speed will increase the temperature rise and a higher blower speed will decrease the temperature rise.

The furnace is equipped with a multi-speed motor. Heating and cooling speed selection is made by moving the switch on the integrated control located in the furnace.

Verifying Burner Operation

CAUTION:

The door over the burners may only be open for inspection purposes only. The door must be installed during unattended operation.

1. Remove the burner compartment door.
2. Set the thermostat above room temperature and observe the ignition sequence. **NOTE:** The burner flame should carry over immediately between all burners without lifting off, curling, or floating. The flames should be blue, without yellow tips.
3. After validating the flame, change thermostat setting to below room temperature.

4. Verify the burner flame is completely extinguished.
5. Replace the burner compartment door.

Verifying Operation of the Supply Air Limit Switch

Note: A properly functioning limit switch should turn off the gas valve when the return is blocked (time depends on how well the return air is blocked). The circulating air and combustion blowers should continue to run when the limit switch opens.

1. Verify the blower door is securely mounted in place and that there is power to the furnace.
2. Block the return airflow to the furnace by installing a close-off plate in place of or upstream of the filter(s).
3. Set the thermostat above room temperature and observe the Operating Sequence.
4. Remove the close-off immediately after the limit switch opens. If the furnace continues to operate with no return air, set the thermostat below room temperature, shut off power to the furnace, and replace the limit switch.

OPERATING SEQUENCE

The operating sequences for the heating, cooling, and fan modes are described below. Refer to the field and furnace wiring diagrams: (Figure 27 page 27), (Figure 28, page 28) and (Figure 32, page 37).

Heating Cycle

1. The thermostat calls for heat by energizing the **W** terminal with 24VAC.
2. The control verifies the pressure switch is open.
3. If the pressure switch is open, the control energizes the inducer and waits for the pressure switch to close. The pressure switch must close within 10 seconds.
4. The control runs the inducer for a 30 second pre-purge.
5. The control energizes the Hot Surface Igniter (HSI) output for the appropriate warm-up time limit.
6. The control energizes the main gas valve for 3 seconds.
7. If the flame proved and ignites the gas, the control de-energizes the HSI. The gas valve and inducer remains energized. The control goes to blower on delay.
8. If flame is present, the control energizes the blower on the selected HEAT speed 30 seconds after the gas valve opened. The gas valve and inducer remain energized.
9. When the thermostat demand for heat is satisfied, the control de-energizes the gas valve. The Inducer output remains on for a 30 second post-purge period.
10. Blower off timing begins when the thermostat is satisfied. The control will operate at the selected HEAT speed of 60, 90, 120, or 180 seconds. If the blower off delay jumper is not present, the fan should still operate for 120 seconds at the selected HEAT speed.

The Indoor blower motor is de-energized after a blower off delay as selected by the movable jumper.

Cooling Cycle

1. The thermostat calls for cooling by energizing the **Y** terminal with 24VAC.
2. The control energizes the blower in cooling speed and sends 24VAC to the contactor in the condensing unit
3. When the thermostat removes the call for cooling, the contactor in the outdoor condensing unit is de-energized and the control continues to run the fan for a period of 60 seconds.

Fan Mode

- When the thermostat energizes the **G** terminal for continuous fan (without calling for heat or cooling), the indoor fan is energized on the selected FAN speed.
- If a call for cooling occurs during continuous fan, the blower will switch over to the selected COOL speed.
- If the **W** terminal receives a call for heat during continuous fan, the blower will de energize.
- A call for fan is ignored while in lockout.

DESCRIPTION OF COMPONENTS

The descriptions below are various functional components that affect the operation and shutting down of this furnace. Some of these components and their locations are shown in Figure 38 (page 47). If any component of the furnace must be replaced, use only factory authorized replacement parts specified in the Replacement Parts List provided online.

Condensate Drain Switch: The Condensate Drain Switch will shut down the furnace if the condensate drain from the Collector Pan becomes clogged.

Blower Limit Switch: Prevents operation when blower is not operational.

Flame Sensor: Verifies when a flame has carried over from the igniter to the opposite end burner. If no flame is detected, the furnace will shut down within 4 seconds.

Flame Roll-Out Switch: Verifies that the burner flames are drawn into the heat exchanger tubes. If the burner flames are not properly drawn into the heat exchanger, the flame roll-out switch will close the gas valve and initiate the shutdown cycle.

Gas Valve: Controls the flow of gas to the burners. When the gas valve is energized it automatically opens and regulates the gas pressure in the manifold.

Inducer Assembly: Vents products of combustion to the outside.

Pressure Switches: Verifies that the inducer is drawing the combustion gases through the heat exchanger. The pressure switch prevents furnace operation with excessive flue/condensate blockage or improper inducer operation.

Supply Air Limit Switch: Prevents the air temperature leaving the furnace from exceeding the maximum allowable outlet air temperature.

MAINTENANCE

Proper maintenance is most important to achieve the best performance from a furnace. Follow these instructions for years of safe, trouble free operation.

WARNING:

ELECTRICAL SHOCK, FIRE OR EXPLOSION HAZARD

Failure to follow safety warnings exactly could result in serious injury or property damage.

Improper servicing could result in dangerous operation, serious injury, death or property damage.

- **Before servicing, disconnect all electrical power to furnace.**
- **When servicing controls, label all wires prior to disconnecting. Reconnect wires correctly.**
- **Verify proper operation after servicing.”**

AVERTISSEMENT:

RISQUE DE CHOC ÉLECTRIQUE, D'INCENDIE OU D'EXPLOSION

Le non-respect des avertissements de sécurité pourrait entraîner un fonctionnement dangereux de l'appareil, des blessures graves, la mort ou des dommages matériels.

Un entreteïn incorrect pourrait entraîner un fonctionnement dangereux de l'appareil, des blessures graves, la mort ou des dommages matériels

- **Couper toute alimentation électrique au générateur d'air chaud avant de prodéder aux travaux d'entreteïn.**
- **Au moment de l'entreteïn des commandes, étiquetez tous les fils avant de les débrancher. S'assurez de les raccorder correctement.**
- **S'assurez que l'appareil fonctionne adéquatement après l'entreteïn.**

- These maintenance instructions are primarily intended to assist qualified technicians experienced in the proper maintenance and operation of this appliance.
- Always reinstall the doors on the furnace after servicing or cleaning/changing the filters. **Do not operate the furnace without all doors and covers in place.**
- Verify the thermostat is properly installed and will not be affected by drafts or heat from lamps or other appliances.
- To achieve the best performance and minimize equipment failure it is recommended that a yearly maintenance checkup be performed. At a minimum, this check should include the following items:

Air Filter(s)

WARNING:

Never operate the furnace without a filter in place. Dust and lint can build up on internal components, resulting in loss of efficiency, equipment damage, and possible fire.

Air filter(s) are not supplied with the furnace as shipped from the factory. The installer must provide a high velocity filter that is appropriately sized to the return air duct opening or external filter rack. It is recommended that filter(s) be 1" or 2" thick and be cleaned or replaced monthly. New or newly renovated homes may require more frequent changing until the construction dust has minimized.

Filters designed to remove smaller particles such as pollen, may require additional maintenance. Filters for side return and bottom return applications are available from most local distributors.

Blower Compartment

Dirt and lint can create excessive loads on the motor resulting in higher than normal operating temperatures and shortened service life. It is recommended that the blower compartment be cleaned of dirt or lint that may have accumulated in the compartment or on the blower and motor as part of the annual inspection.

Cleaning of Burners

If the burners must be cleaned, follow steps 1-12. See Figure 38 (page 47) for component location.

1. Shut off gas supply to the furnace at the meter or at a manual valve in the supply piping.
2. Turn off all power to the furnace and set the thermostat to it's lowest setting.
3. Remove the burner door from the furnace.
4. Turn the gas control switch to the OFF position.
5. Disconnect the wires from the gas valve, igniter, flame sensor, and flame rollout switch.

CAUTION:

To prevent damage to the unit or internal components, it is recommended that two wrenches be used when loosening or tightening nuts. Do not over tighten!

6. Using two wrenches, separate the ground-joint union in the gas supply piping at the furnace.
7. Remove the piping between the Gas Valve and the ground-joint union. (If applicable).
8. Remove all screws securing the Manifold Assembly to the Burner Box.
9. Carefully remove the burner assembly from the furnace. **DO NOT DAMAGE THE IGNITER WHILE REMOVING THE BURNER ASSEMBLY.**
10. Inspect the burners for accumulated dust or debris. If necessary carefully clean them with a soft wire brush and a vacuum cleaner. **DO NOT DAMAGE THE IGNITER WHILE CLEANING THE BURNER.**
11. Replace all the parts in reverse order from which they were removed.
12. Follow the lighting instructions found on the furnace door to return the furnace to operation. Verify proper operation after servicing.

Vent System

WARNING:

Holes in the vent pipe or heat exchanger can cause combustion products to enter the home. Replace the vent pipe or heat exchanger if leaks are found. Failure to prevent the circulation of combustion products into the living space can create potentially hazardous conditions including carbon monoxide poisoning that could result in personal injury or death.

Check the inlet pipe (if applicable) and outlet pipe to ensure they are not blocked by debris. Any damaged section of vent pipe must be replaced, and any obstruction or blockage must be removed prior to operating the furnace.

Heat Exchanger and Burner Maintenance

The furnace should operate for many years without soot buildup in the flue passageways, however, the flue, vent system, and burners should be inspected and cleaned (if required) by a qualified service technician annually to ensure continued safe operation. Pay attention to any deterioration from corrosion or other sources.

Lubrication

The bearings in the blower motor and inducer blower used in these furnaces are pre-lubricated and sealed by the manufacturer. No further oiling of the bearings is required for the life of the motor.

FIGURES & TABLES

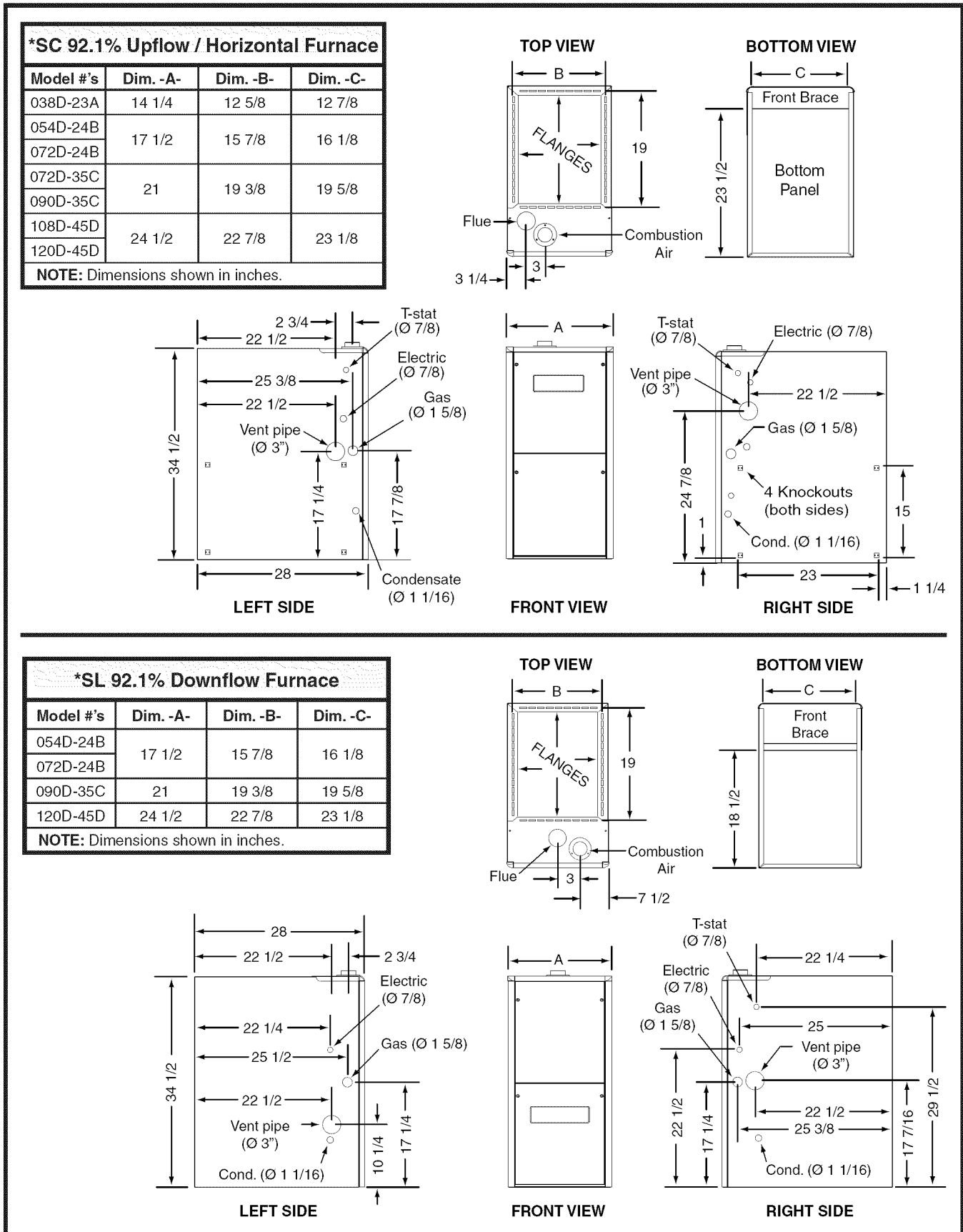

Figure 31. Furnace Dimensions

AIRFLOW DATA

*SC - UPFLOW / HORIZONTAL FURNACES																	
Model Number & Heating Input (Btuh)	Motor Speed	External Static Pressure (Inches Water Column)															
		0.1		0.2		0.3		0.4		0.5		0.6		0.7		0.8	
		CFM	Rise	CFM	Rise	CFM	Rise	CFM	Rise	CFM	Rise	CFM	Rise	CFM	Rise	CFM	Rise
SC038D-23A Bottom Return (38,000)	High*	1,245	26	1,200	27	1,150	28	1,100	29	1,050	31	985	33	920	35	865	37
	Med-High	1,115	29	1,075	30	1,030	31	990	33	935	35	880	37	815	40	740	44
	Med-Low**	785	41	770	42	745	43	720	45	680	48	640	51	595	54	530	61
	Low	645	50	630	51	610	53	580	56	555	58	525	62	480	67	420	77
SC038D-23A Side Return (38,000)	High*	1,330	24	1,285	25	1,230	26	1,175	28	1,125	29	1,055	31	985	33	925	35
	Med-High	1,195	27	1,150	28	1,100	29	1,060	31	1,000	32	940	34	875	37	790	41
	Med-Low**	840	39	825	39	800	40	770	42	730	44	685	47	640	51	560	58
	Low	680	48	675	48	655	49	620	52	600	54	560	58	515	63	450	72
SC054D-24B Bottom Return (54,000)	High*	1,550	30	1,520	30	1,485	31	1,450	32	1,410	33	1,360	34	1,300	35	1,255	37
	Med-High	1,250	37	1,220	38	1,200	38	1,170	39	1,140	40	1,105	42	1,065	43	1,010	46
	Med-Low**	935	49	910	51	880	52	850	54	815	56	785	59	735	63	680	68
	Low	720	64	690	67	655	70	620	74	585	79	550	84	520	88	485	95
SC054D-24B Side Return (54,000)	High*	1,630	28	1,595	29	1,560	29	1,525	30	1,480	31	1,430	32	1,365	34	1,320	35
	Med-High	1,315	35	1,280	36	1,260	37	1,230	37	1,200	38	1,160	40	1,120	41	1,060	43
	Med-Low**	980	47	955	48	925	50	890	52	855	54	825	56	775	59	715	64
	Low	755	61	725	63	690	67	650	71	615	75	580	79	545	84	510	90
SC072D-24B Bottom Return (72,000)	High*	1,590	39	1,550	40	1,525	40	1,475	42	1,425	43	1,380	44	1,325	46	1,240	49
	Med-High**	1,260	49	1,240	49	1,220	50	1,185	52	1,160	53	1,110	55	1,085	57	1,030	60
	Med-Low	1,125	55	1,110	55	1,085	57	1,050	58	1,025	60	990	62	940	65	865	71
	Low	895	69	865	71	830	74	795	77	775	79	750	82	693	89	665	92
SC072D-24B Side Return (72,000)	High*	1,670	37	1,630	38	1,600	38	1,550	40	1,495	41	1,450	42	1,390	44	1,300	47
	Med-High**	1,325	46	1,300	47	1,280	48	1,245	49	1,220	50	1,165	53	1,140	54	1,080	57
	Med-Low	1,180	52	1,165	53	1,140	54	1,100	56	1,075	57	1,040	59	985	62	910	67
	Low	940	65	910	67	870	70	935	66	815	75	790	78	730	84	640	96
SC072D-35C Bottom Return (72,000)	High*	1,895	32	1,790	34	1,720	36	1,630	38	1,550	40	1,445	42	1,330	46	1,225	50
	Med-High**	1,775	35	1,710	36	1,650	37	1,550	40	1,470	42	1,385	44	1,290	48	1,180	52
	Med-Low	1,255	49	1,200	51	1,155	53	1,105	56	1,050	58	1,000	61	925	66	830	74
	Low	1,140	54	1,100	56	1,065	58	1,025	60	980	63	930	66	870	70	805	76
SC072D-35C Side Return (72,000)	High*	1,970	31	1,865	33	1,780	34	1,695	36	1,615	38	1,505	41	1,385	44	1,275	48
	Med-High**	1,845	33	1,780	34	1,715	36	1,615	38	1,530	40	1,440	43	1,340	46	1,230	50
	Med-Low	1,305	47	1,250	49	1,200	51	1,150	53	1,090	56	1,040	59	965	64	865	71
	Low	1,185	52	1,145	54	1,110	55	1,065	58	1,020	60	965	64	905	68	840	73
SC072D-35C Side + Bottom or 2 Sides (72,000)	High*	1,990	31	1,880	33	1,805	34	1,710	36	1,630	38	1,510	41	1,400	44	1,285	48
	Med-High**	1,865	33	1,795	34	1,735	35	1,630	38	1,545	40	1,455	42	1,355	45	1,240	49
	Med-Low	1,320	46	1,260	49	1,215	50	1,160	53	1,105	56	1,050	58	970	63	875	70
	Low	1,200	51	1,155	53	1,120	55	1,075	57	1,030	60	975	63	915	67	845	73

Table 6. Maximum Airflow & Temperature Rises (° F) - Upflow / Horizontal Furnaces

***SC - UPFLOW / HORIZONTAL FURNACES**

Model Number & Heating Input (Btuh)	Motor Speed	External Static Pressure (Inches Water Column)															
		0.1		0.2		0.3		0.4		0.5		0.6		0.7		0.8	
		CFM	Rise	CFM	Rise	CFM	Rise	CFM	Rise	CFM	Rise	CFM	Rise	CFM	Rise	CFM	Rise
SC090D-35C Bottom Return (90,000)	High*	2,155	36	2,090	37	2,015	38	1,960	39	1,910	40	1,835	42	1,755	44	1,660	46
	Med-High**	2,015	38	1,960	39	1,920	40	1,860	41	1,805	42	1,755	44	1,695	45	1,615	47
	Med-Low	1,705	45	1,675	46	1,640	47	1,590	48	1,555	49	1,495	51	1,435	53	1,340	57
	Low	1,410	54	1,390	55	1,365	56	1,330	58	1,310	59	1,275	60	1,235	62	1,210	63
SC090D-35C Bottom Return (90,000)	High*	2,155	36	2,090	37	2,015	38	1,960	39	1,910	40	1,835	42	1,755	44	1,660	46
	Med-High**	2,015	38	1,960	39	1,920	40	1,860	41	1,805	42	1,755	44	1,695	45	1,615	47
	Med-Low	1,705	45	1,675	46	1,640	47	1,590	48	1,555	49	1,495	51	1,435	53	1,340	57
	Low	1,410	54	1,390	55	1,365	56	1,330	58	1,310	59	1,275	60	1,235	62	1,210	63
SC090-35C Side Return (90,000)	High*	2,240	34	2,175	35	2,100	37	2,040	38	1,985	39	1,910	40	1,825	42	1,725	44
	Med-High**	2,095	37	2,040	38	2,000	38	1,935	40	1,875	41	1,825	42	1,765	43	1,680	46
	Med-Low	1,775	43	1,740	44	1,705	45	1,655	46	1,615	47	1,555	49	1,490	51	1,335	57
	Low	1,465	52	1,445	53	1,420	54	1,385	55	1,360	56	1,325	58	1,285	60	1,260	61
SC090-35C Side + Bottom or 2 Sides (90,000)	High*	2,265	34	2,195	35	2,115	36	2,060	37	2,005	38	1,930	40	1,845	42	1,745	44
	Med-High**	2,115	36	2,060	37	2,015	38	1,955	39	1,895	40	1,845	42	1,780	43	1,695	45
	Med-Low	1,790	43	1,760	44	1,725	44	1,670	46	1,635	47	1,570	49	1,510	51	1,410	54
	Low	1,480	52	1,460	53	1,435	53	1,400	55	1,375	56	1,340	57	1,300	59	1,270	60
SC108-45D Bottom only or 2 openings (108,000)	High*	2,135	43	2,095	44	2,040	45	1,975	47	1,910	48	1,840	50	1,735	53	1,675	55
	Med-High**	2,000	46	1,955	47	1,900	48	1,845	50	1,800	51	1,735	53	1,665	55	1,570	59
	Med-Low	1,665	55	1,660	55	1,625	57	1,590	58	1,530	60	1,500	61	1,415	65	1,340	69
	Low	1,385	66	1,360	68	1,310	70	1,300	71	1,275	72	1,250	74	1,200	77	1,150	80
SC108-45D Side Return (108,000)	High*	2,115	43	2,075	44	2,020	46	1,955	47	1,890	49	1,822	50	1,720	53	1,660	55
	Med-High**	1,980	46	1,935	48	1,880	49	1,830	50	1,780	52	1,720	53	1,650	56	1,555	59
	Med-Low	1,650	56	1,645	56	1,610	57	1,575	58	1,515	61	1,485	62	1,400	66	1,330	69
	Low	1,370	67	1,345	68	1,300	71	1,290	71	1,260	73	1,240	74	1,190	77	1,140	81
SC120-45D Bottom only or 2 openings (120,000)	High*	2,135	48	2,095	49	2,040	50	1,975	52	1,910	54	1,840	56	1,735	59	1,675	61
	Med-High**	2,000	51	1,955	52	1,900	54	1,845	55	1,800	57	1,735	59	1,665	61	1,570	65
	Med-Low	1,665	61	1,660	62	1,625	63	1,590	64	1,530	67	1,500	68	1,415	72	1,340	76
	Low	1,385	74	1,360	75	1,310	78	1,300	79	1,275	80	1,250	82	1,200	85	1,150	89
SC120-45D Side Return (120,000)	High*	2,115	48	2,075	49	2,020	51	1,955	52	1,890	54	1,822	56	1,720	59	1,660	62
	Med-High**	1,980	52	1,935	53	1,880	54	1,830	56	1,780	57	1,720	59	1,650	62	1,555	66
	Med-Low	1,650	62	1,645	62	1,610	63	1,575	65	1,515	67	1,485	69	1,400	73	1,330	77
	Low	1,370	75	1,345	76	1,300	79	1,290	79	1,260	81	1,240	82	1,190	86	1,140	90

NOTES:

* Factory Set Cooling Speed

** Factory Set Heating Speed

- Two openings are recommended for airflows above 1,600 CFM if filter(s) is(are) adjacent to furnace
- Temperature rises in the table are approximate. Actual temperature rises may vary.
- Temperature rises shaded in gray are for reference only. These conditions are not recommended

Table 6. Continued

***SL - DOWNFLOW GAS FURNACES**

Model Number & Heating Input (Btuh)	Motor Speed	External Static Pressure (Inches Water Column)															
		0.1		0.2		0.3		0.4		0.5		0.6		0.7		0.8	
		CFM	Rise	CFM	Rise	CFM	Rise	CFM	Rise	CFM	Rise	CFM	Rise	CFM	Rise	CFM	Rise
SL054-24B 54,000	HIGH*	1,580	29	1,550	30	1,520	30	1,485	31	1,460	32	1,425	32	1,375	33	1,320	35
	MED-HIGH	1,240	37	1,230	37	1,210	38	1,185	39	1,165	39	1,135	41	1,100	42	1,045	44
	MED-LOW**	1,145	40	1,120	41	1,100	42	1,080	43	1,055	44	1,030	45	985	47	940	49
	LOW	895	51	870	53	850	54	825	56	800	58	770	60	740	62	715	64
SL072-24B 72,000	HIGH*	1,560	39	1,530	40	1,500	41	1,480	41	1,435	43	1,400	44	1,360	45	1,310	47
	MED-HIGH**	1,245	49	1,225	50	1,205	51	1,180	52	1,150	53	1,125	55	1,090	56	1,045	59
	MED-LOW	1,085	57	1,070	57	1,045	59	1,025	60	1,000	61	970	63	930	66	880	70
	LOW	850	72	830	74	800	77	780	79	760	81	730	84	710	86	685	90
SL090-35C 90,000	HIGH*	1,955	39	1,905	40	1,835	42	1,795	43	1,730	44	1,620	47	1,545	50	1,450	53
	MED-HIGH**	1,845	42	1,790	43	1,750	44	1,680	46	1,515	51	1,540	50	1,475	52	1,410	54
	MED-LOW	1,320	58	1,290	59	1,250	61	1,215	63	1,180	65	1,120	68	1,050	73	970	79
	LOW	1,190	64	1,165	66	1,125	68	1,080	71	1,055	73	1,000	77	945	81	875	88
SL120-45D 120,000	HIGH*	2,215	46	2,150	48	2,075	49	2,035	50	1,970	52	1,905	54	1,800	57	1,745	59
	MED-HIGH**	2,050	50	2,015	51	1,955	52	1,900	54	1,860	55	1,795	57	1,720	59	1,620	63
	MED-LOW	1,720	59	1,690	60	1,655	62	1,640	62	1,610	63	1,560	66	1,505	68	1,465	70
	LOW	1,420	72	1,410	72	1,400	73	1,365	75	1,350	76	1,335	77	1,290	79	1,260	81

NOTES:

* Factory Set Cooling Speed

** Factory Set Heating Speed

1. Temperature rises in the table are approximate. Actual temperature rises may vary.

2. Temperature rises shaded in gray are for reference only. These conditions are not recommended.

Table 7. Maximum Airflow & Temperature Rises (° F) - Downflow Furnaces

TROUBLESHOOTING

If the furnace fails to operate check the following:

- Is the thermostat operating properly?
- Are the blower compartment door(s) in place?
- Is the furnace disconnect closed?
- Has the circuit breaker tripped or the control board fuse burned open?
- Is the gas turned on?
- Are any manual reset switches open?
- Is the filter dirty or plugged?
- Is the flame sensor coated? (Remove and clean with steel wool. **(Do not use emery cloth or sandpaper!)**)
- Is there blockage in the condensate drain switch? Also verify that there is no double trapping of condensate.
- Is the secondary heat exchanger free of debris and clogs?
- Is evaporator coil clean and free of debris (If applicable).
- Are all the LED's on the furnace control board constantly ON? If not, refer to Table 8 or the wiring diagram (Figure 32, page 37) to determine fault condition.

IMPORTANT NOTE: The furnace will lock out after 5 failed attempts for ignition and will try again every hour if the call for heat remains.

- If the Inducer Blower is operating, and items above have been verified, check the Blower Limit Switch and reset if necessary. See Figure 38 (page 47) for component location.

- If the furnace operates when the Blower Limit Switch is reset, contact a qualified service technician to identify and repair the problem.
- If the furnace still doesn't operate, check the Flame Roll-out Switches (Figure 38) and reset if necessary.
- If the furnace operates when the Flame Rollout Switch is reset, contact a qualified service technician to identify and repair the problem.

Diagnostic Description	Green LED	Red LED
Control Fault (No Power)	Off	Off
L1/Neutral Polarity Fault	Flash	Flash
1 Hour Lockout	Alternating Flash	
Normal Operation	On	On
Pressure Switch Closed Fault	On	Flash
Pressure Switch Open Fault	Flash	On
Open Limit Switch Fault	Flash	Off
Motor Fault	On	Off
Diagnostic Description	Yellow LED	
Low Flame Sensor Signal	Continuous Flash	
Flame Present	On	

Table 8. Control Board Fault Conditions

WIRING DIAGRAM

For 80+ and 90+ Single Stage Furnaces

Refer to the Installation Instructions provided with the kit for the proper heating and cooling speeds for your application.

If any of the original wire as supplied with the furnace must be replaced, it must be replaced with wiring material having a temperature rating of at least 105° C.

Use copper conductors only.

FAULT CONDITIONS		
Diagnostic Description	Green LED	Red LED
Control Fault (No Power)	Off	Off
L1 / Neutral Polarity Fault	Flash	Flash
1 Hour Lockout	Alternating Flash	
Normal Operation	On	On
Pressure Switch Closed Fault	On	Flash
Pressure Switch Open Fault	Flash	On
Open Limit Switch Fault	Flash	Off
Yellow LED		
Low Flame Sensor Signal	Continuous Flash	
Flame Present	On	

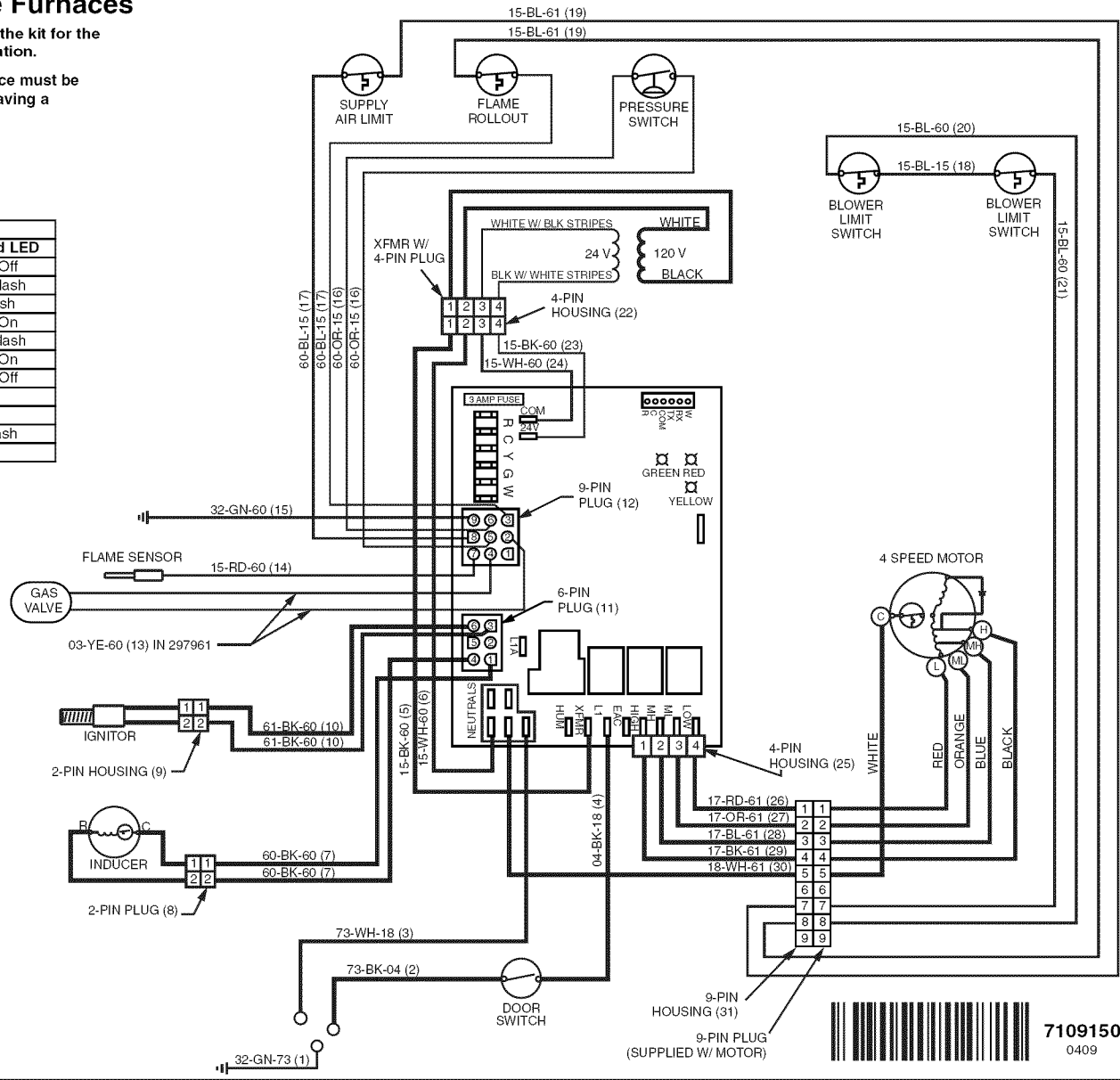

LEGEND:

FIELD WIRING	---
LOW VOLTAGE	---
HIGH VOLTAGE	---



7109150
0409

Figure 32. Wiring Diagram for Upflow & Downflow Furnaces

ELECTRICAL INFORMATION

GAS INFORMATION

GAS FLOW RATES			
TIME FOR ONE REVOLUTION (SECONDS)	CUBIC FEET PER REVOLUTION OF GAS METER		
	1	5	10
10	360	1,800	3,600
12	300	1,500	3,000
14	257	1,286	2,571
16	225	1,125	2,250
18	200	1,000	2,000
20	180	900	1,800
22	164	818	1,636
24	150	750	1,500
26	138	692	1,385
28	129	643	1,286
30	120	600	1,200
32	113	563	1,125
34	106	529	1,059
36	100	500	1,000
38	95	474	947
40	90	450	900
42	86	429	857
44	82	409	818
46	78	391	783
48	75	375	750
50	72	360	720
52	69	346	692
54	67	333	667
56	64	321	643
58	62	310	621
60	60	300	600
62	58	290	581
64	56	281	563

GAS FLOW RATES			
TIME FOR ONE REVOLUTION (SECONDS)	CUBIC FEET PER REVOLUTION OF GAS METER		
	1	5	10
66	55	273	545
68	53	265	529
70	51	257	514
72	50	250	500
74	49	243	486
76	47	237	474
78	46	231	462
80	45	225	450
82	44	220	439
84	43	214	429
86	42	209	419
88	41	205	409
90	40	200	400
92	39	196	391
94	38	191	383
96	38	188	375
98	37	184	367
100	36	180	360
102	35	176	353
104	35	173	346
106	34	170	340
108	33	167	333
110	33	164	327
112	32	161	321
114	32	158	316
116	31	155	310
118	31	153	305
120	30	150	300

Table 9. Gas Flow Rates (Cubic Feet per Hour)

GAS PIPE CAPACITIES								
Nominal Pipe Diameter (IN.)	Length of Pipe Run (Feet)							
	10	20	30	40	50	60	70	80
1/2	130	90	75	65	55	50	45	40
3/4	280	190	150	130	115	105	95	90
1	520	350	285	245	215	195	180	170
1 1/4	1,050	730	590	500	440	400	370	350
1 1/2	1,600	1,100	890	760	670	610		

$$\text{Cubic Feet Per Hour Required} = \frac{\text{Input To Furnace (Btu/hr)}}{\text{Heating Value of Gas (Btu/Cu. Ft.)}}$$

NOTE: The cubic feet per hour listed in the table above must be greater than the cubic feet per hour of gas flow required by the furnace. To determine the cubic feet per hour of gas flow required by the furnace, divide the input rate of the furnace by the heating value (from gas supplier) of the gas.

**Table 10. Capacity of Black Iron Gas Pipe (cu. ft. per hour)
for Natural Gas w/ Specific Gravity = 0.60**

PROPANE DERATION CHART							
ALTITUDE ABOVE SEA LEVEL	INPUT (BTU)						
	38,000	54,000	72,000	90,000	108,000	120,000	
0 to 1,999 FT	56	56	56	56	56	55	ORIFICE SIZE
	10.0	10.0	10.0	10.0	10.0	10.0	MANIFOLD PRESSURE
2,000 to 2,999 FT	56	56	56	56	56	55	ORIFICE SIZE
	9.0	9.0	9.0	9.0	9.0	9.0	MANIFOLD PRESSURE
3,000 to 4,999 FT	56	56	56	56	56	55	ORIFICE SIZE
	8.5	8.5	8.5	8.5	8.5	8.5	MANIFOLD PRESSURE
5,000 to 5,999 FT	57	57	57	57	57	56	ORIFICE SIZE
	10.0	10.0	10.0	10.0	10.0	10.0	MANIFOLD PRESSURE
6,000 to 7,999 FT	57	57	57	57	57	56	ORIFICE SIZE
	9.0	9.0	9.0	9.0	9.0	9.0	MANIFOLD PRESSURE
8,000 to 10,000 FT	57	57	57	57	57	56	ORIFICE SIZE
	8.5	8.5	8.5	8.5	8.5	8.5	MANIFOLD PRESSURE

Table 11. High Altitude Deration Chart for Propane Gas

LOCAL HEATING VALUES FOR NATURAL GAS									
ALTITUDE ABOVE SEA LEVEL	BTU PER CUBIC FOOT								
	650	700	750	800	850	900	950	1,000	1,050
2,000 FT	LOW	LOW	LOW	LOW	LOW	LOW	HIGH	HIGH	HIGH
3,000 FT	LOW	LOW	LOW	LOW	LOW	LOW	HIGH	HIGH	HIGH
4,000 FT	LOW	LOW	LOW	LOW	LOW	HIGH	HIGH	HIGH	HIGH
5,000 FT	LOW	LOW	LOW	LOW	LOW	HIGH	HIGH	HIGH	HIGH
6,000 FT	LOW	LOW	LOW	LOW	HIGH	HIGH	HIGH	HIGH	HIGH
7,000 FT	LOW	LOW	LOW	LOW	HIGH	HIGH	HIGH	HIGH	HIGH
8,000 FT	LOW	LOW	LOW	HIGH	HIGH	HIGH	HIGH	HIGH	HIGH
9,000 FT	LOW	LOW	LOW	HIGH	HIGH	HIGH	HIGH	HIGH	HIGH
10,000 FT	LOW	LOW	HIGH	HIGH	HIGH	HIGH	HIGH	HIGH	HIGH

Table 12. Natural Gas Heating Values

NATURAL GAS with HIGH HEATING VALUE							
ALTITUDE ABOVE SEA LEVEL	INPUT (BTU)						
	38,000	54,000	72,000	90,000	108,000	120,000	
0 to 1,999 FT	45	47	47	47	47	47	ORIFICE SIZE
	3.5	3.5	3.5	3.5	3.5	3.5	MANIFOLD PRESSURE
2,000 to 2,999 FT	45	47	47	47	47	47	ORIFICE SIZE
	3.0	3.2	3.2	3.2	3.2	3.2	MANIFOLD PRESSURE
3,000 to 3,999 FT	45	47	47	47	47	47	ORIFICE SIZE
	2.8	3.0	3.0	3.0	3.0	3.0	MANIFOLD PRESSURE
4,000 to 4,999 FT	45	47	47	47	47	47	ORIFICE SIZE
	2.7	2.8	2.8	2.8	2.8	2.8	MANIFOLD PRESSURE
5,000 to 5,999 FT	45	47	47	47	47	47	ORIFICE SIZE
	2.5	2.7	2.7	2.7	2.7	2.7	MANIFOLD PRESSURE
6,000 to 6,999 FT	49	49	49	49	49	49	ORIFICE SIZE
	3.5	3.5	3.5	3.5	3.5	3.5	MANIFOLD PRESSURE
7,000 to 7,999 FT	49	49	49	49	49	49	ORIFICE SIZE
	3.4	3.3	3.3	3.3	3.3	3.3	MANIFOLD PRESSURE
8,000 to 8,999 FT	49	49	49	49	49	49	ORIFICE SIZE
	3.2	3.0	3.0	3.0	3.0	3.0	MANIFOLD PRESSURE
9,000 to 9,999 FT	49	49	49	49	49	49	ORIFICE SIZE
	3.0	2.8	2.8	2.8	2.8	2.8	MANIFOLD PRESSURE

Table 13. High Altitude Deration Chart for Natural Gas - High Heating Value

NATURAL GAS with LOW HEATING VALUE							
ALTITUDE ABOVE SEA LEVEL	INPUT (BTU)						
	38,000	54,000	72,000	90,000	108,000	120,000	
0 to 1,999 FT	45	47	47	47	47	47	ORIFICE SIZE
	3.5	3.5	3.5	3.5	3.5	3.5	MANIFOLD PRESSURE
2,000 to 2,999 FT	45	47	47	47	47	47	ORIFICE SIZE
	3.5	3.5	3.5	3.5	3.5	3.5	MANIFOLD PRESSURE
3,000 to 3,999 FT	45	47	47	47	47	47	ORIFICE SIZE
	3.1	3.3	3.3	3.3	3.3	3.3	MANIFOLD PRESSURE
4,000 to 4,999 FT	45	47	47	47	47	47	ORIFICE SIZE
	2.9	3.1	3.1	3.1	3.1	3.1	MANIFOLD PRESSURE
5,000 to 5,999 FT	45	47	47	47	47	47	ORIFICE SIZE
	2.8	2.9	2.9	2.9	2.9	2.9	MANIFOLD PRESSURE
6,000 to 6,999 FT	45	47	47	47	47	47	ORIFICE SIZE
	2.6	2.8	2.8	2.8	2.8	2.8	MANIFOLD PRESSURE
7,000 to 7,999 FT	48	49	49	49	49	49	ORIFICE SIZE
	3.3	3.4	3.4	3.4	3.4	3.4	MANIFOLD PRESSURE
8,000 to 8,999 FT	48	49	49	49	49	49	ORIFICE SIZE
	3.0	3.2	3.2	3.2	3.2	3.2	MANIFOLD PRESSURE
9,000 to 9,999 FT	48	49	49	49	49	49	ORIFICE SIZE
	2.8	2.9	2.9	2.9	2.9	2.9	MANIFOLD PRESSURE

Table 14. High Altitude Deration Chart for Natural Gas - Low Heating Value

VENTING INFORMATION

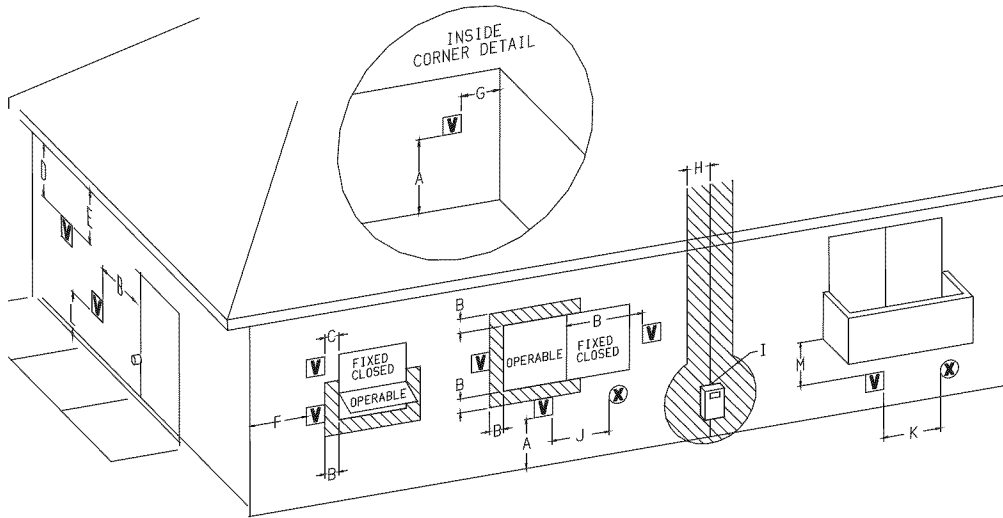

V VENT TERMINAL

X AIR SUPPLY INLET

▨ AREA WHERE TERMINAL IS NOT PERMITTED

Clearance Location	CANADIAN INSTALLATIONS ^a	US INSTALLATIONS ^b		
	Direct Vent (2-pipe) & Conventional Vent (1-pipe) Furnaces	Direct Vent (2-pipe) Furnaces	Conventional Vent (1-pipe) Furnaces	
A	Clearance above grade, veranda, porch, deck, balcony, or maximum expected snow level.	12 inches (30cm)	12 inches (30cm)	12 inches (30cm)
B	Clearance to window or door that may be opened.	6 inches (15cm) for appliances < 10,000 Btuh (3kW)	6 inches (15cm) for appliances < 10,000 Btuh (3kW)	4 ft. (1.2m) below or to side of opening; 1 ft. (300mm) above opening
		12 inches (30cm) for appliances 10,000 Btuh - 100,000 Btuh (30kW)	9 inches (23cm) for appliances 10,000 Btuh - 50,000 Btuh (30kW)	
		36 inches (91cm) for appliances > 100,000 Btuh (30Kw)	12 inches (30cm) for appliances > 50,000 Btuh (30Kw)	
C	Clearance to permanently closed window	*	*	*
D	Vertical clearance to ventilated soffit located above the terminal within a horizontal distance of 2 feet (61cm) from the center line of the terminal.	*	*	*
E	Clearance to unventilated soffit.	*	*	*
F	Clearance to outside corner.	*	*	*
G	Clearance to inside corner.	*	*	*
H	Clearance to each side of center line extended above meter/regulator assembly.	3 feet (91cm) within a height 15 feet above the meter/regulator assembly	*	*
I	Clearance to service regulator vent outlet.	3 feet (1.83m)	*	*
J	Clearance to non-mechanical air supply inlet to building or the combustion air inlet to any other appliance.	6 inches (15cm) for appliances < 10,000 Btuh (3kW)	6 inches (15cm) for appliances < 10,000 Btuh (3kW)	4 ft. (1.2m) below or to side of opening; 1 ft. (300mm) above opening
		12 inches (30cm) for appliances 10,000 Btuh - 100,000 Btuh (30kW)	9 inches (23cm) for appliances 10,000 Btuh - 50,000 Btuh (30kW)	
		36 inches (91cm) for appliances > 100,000 Btuh (30Kw)	12 inches (30cm) for appliances > 50,000 Btuh (30Kw)	
K	Clearance to mechanical air supply inlet.	6 feet (1.83m)	3 feet (91cm) above if within 10 feet (3m) horizontally	3 ft. (91cm) above if within 10 feet (3m) horizontally
L	Clearance above paved sidewalk or driveway located on public property.	7 feet (2.13m) ^c	*	7 ft. (2.13m)
M	Clearance under veranda, porch, deck, or balcony.	12 inches (30cm) ^d	*	*
NOTES:				
a	In accordance with the current CSA B149.1 Natural Gas and Propane Installation Guide Code			
b	In accordance with the current ANSI Z223.1 / NFPA 54 Natural Fuel Gas Code			
c	A vent shall not terminate directly above a sidewalk or paved driveway that is located between two single family dwellings and serves both dwellings.			
d	Permitted only if veranda, porch, deck, or balcony is fully open on a minimum of two sides beneath the floor.			
*	For clearances not specified in ANSI Z223.1 / NFPA 54 or CSA B149.1, the following statement shall be included: "Clearance in accordance with local installation codes, and the requirements of the gas supplier and the manufacturers installation instructions." / "Dégagement conforme aux codes d'installation locaux, aux exigences du fournisseur de gaz et aux instructions d'installation du fabricant".			

Table 15. Vent Termination Clearances

HORIZONTAL VENTING

(2-Pipe Shown)

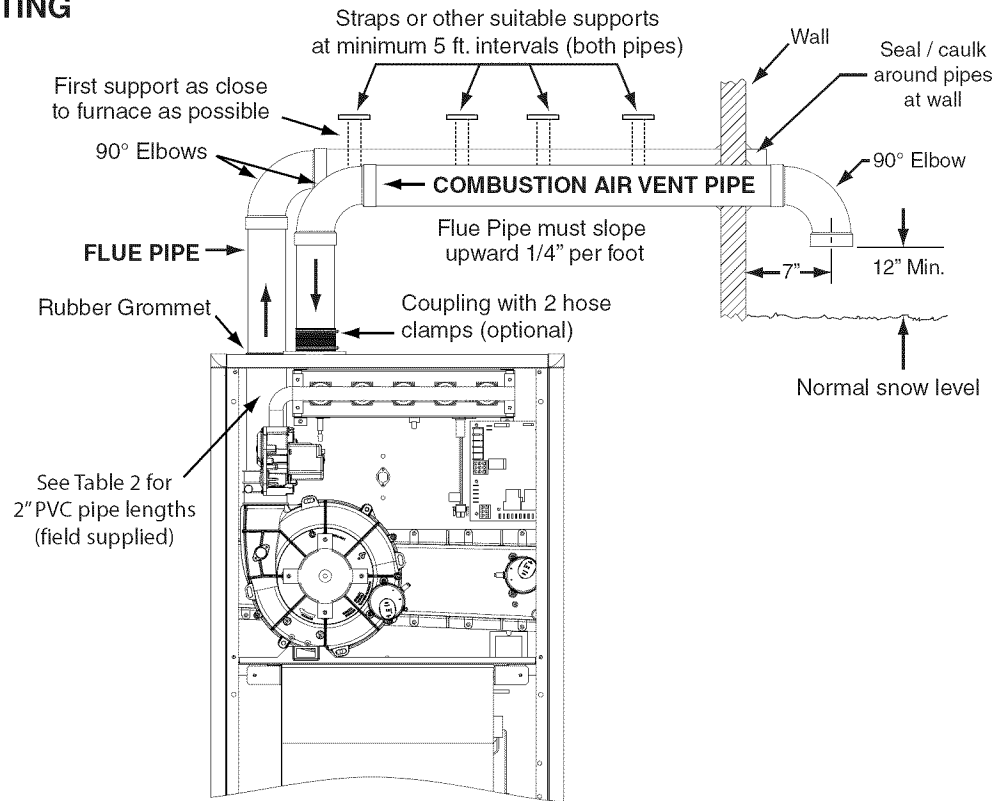

VERTICAL VENTING

(2-Pipe Shown)

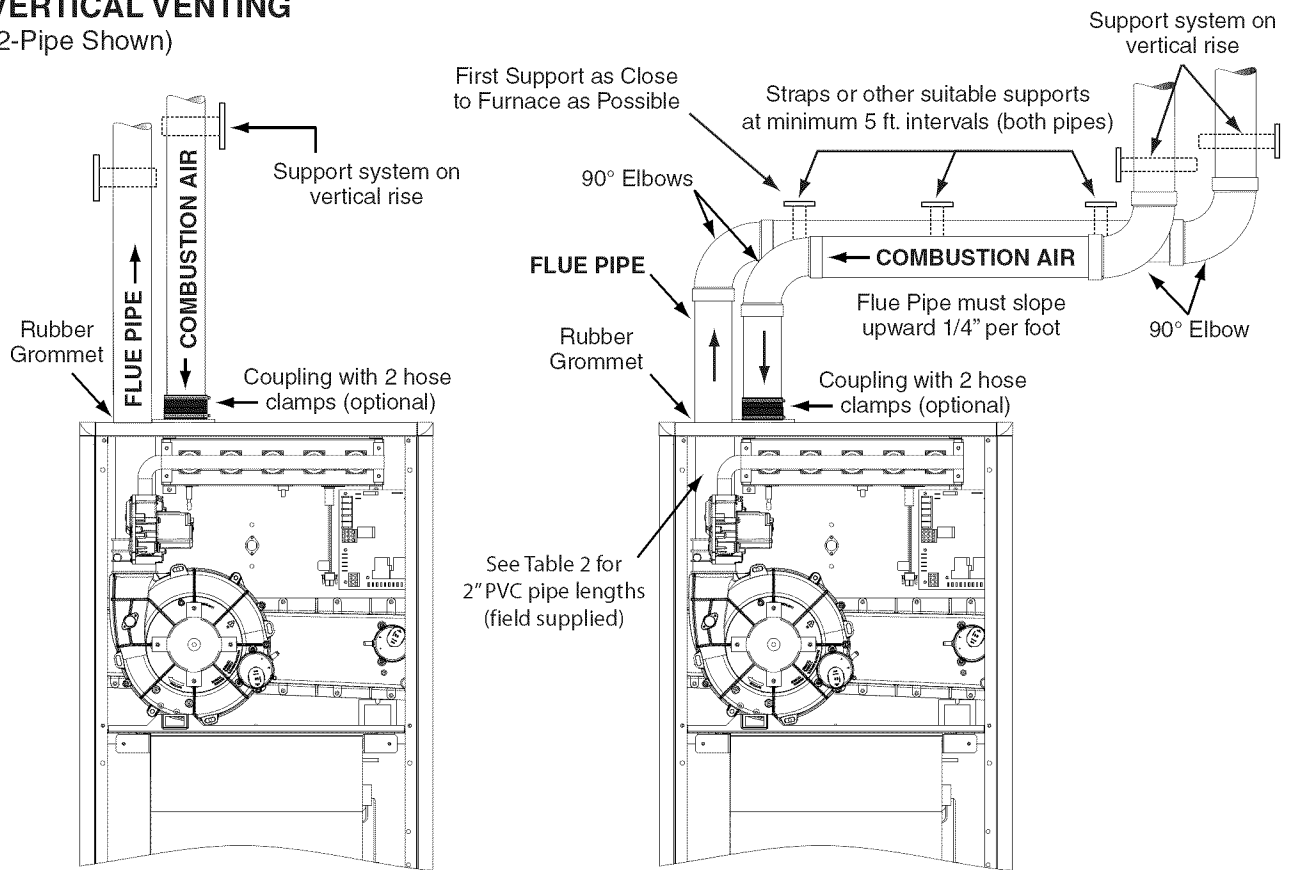
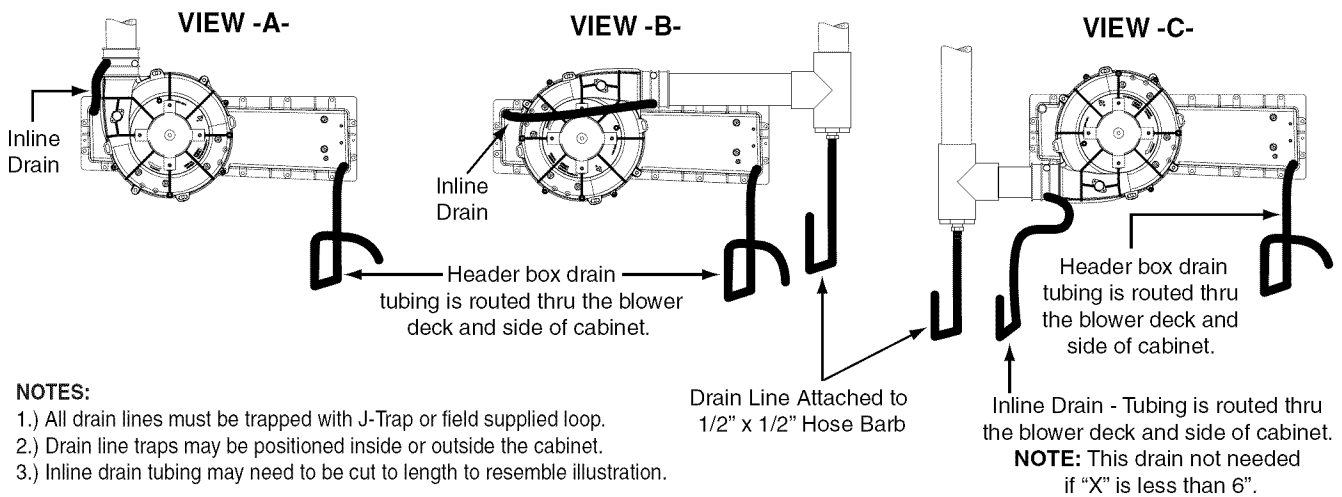
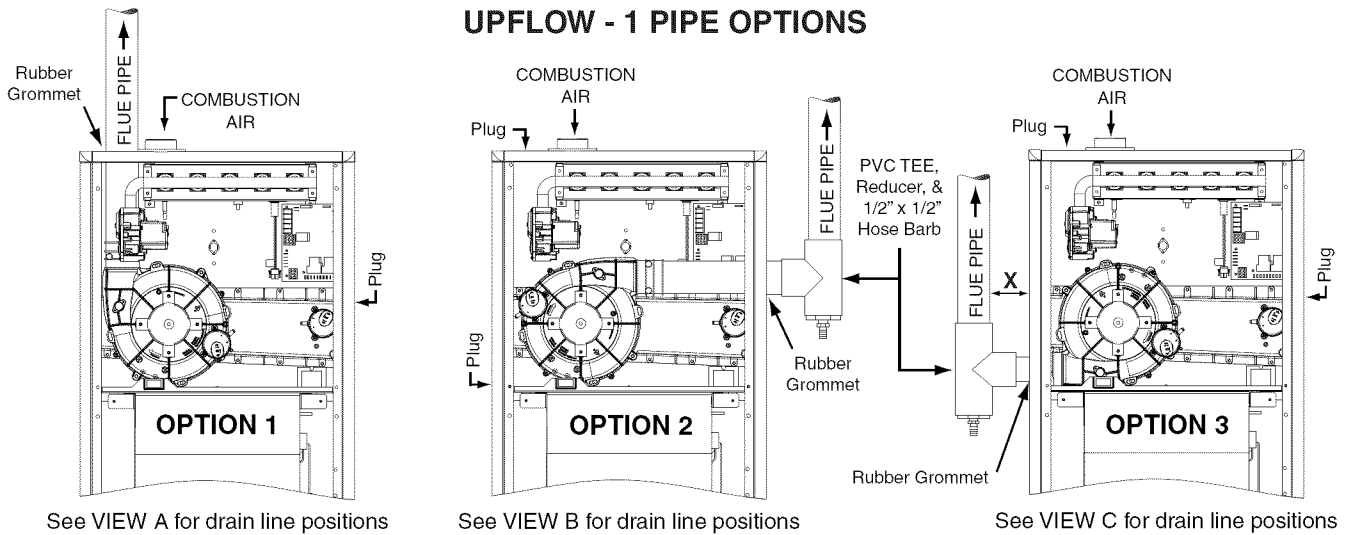

Figure 33. Horizontal & Vertical Venting

UPFLOW - 1 PIPE OPTIONS



UPFLOW - 2 PIPE OPTIONS

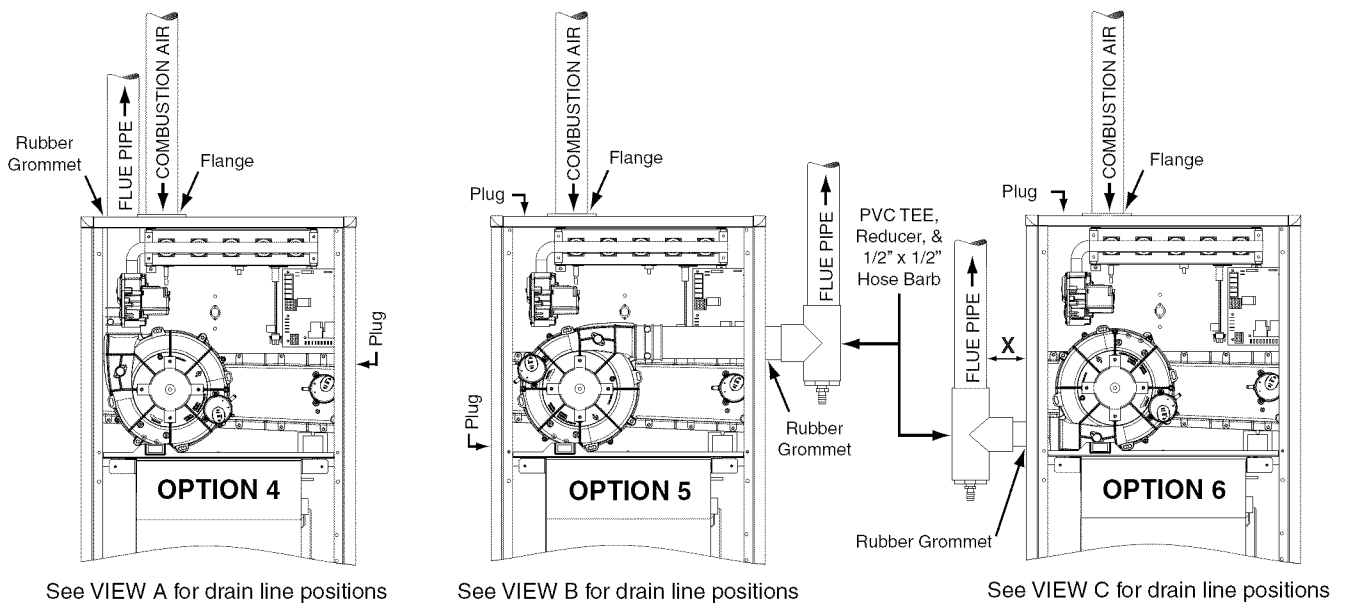
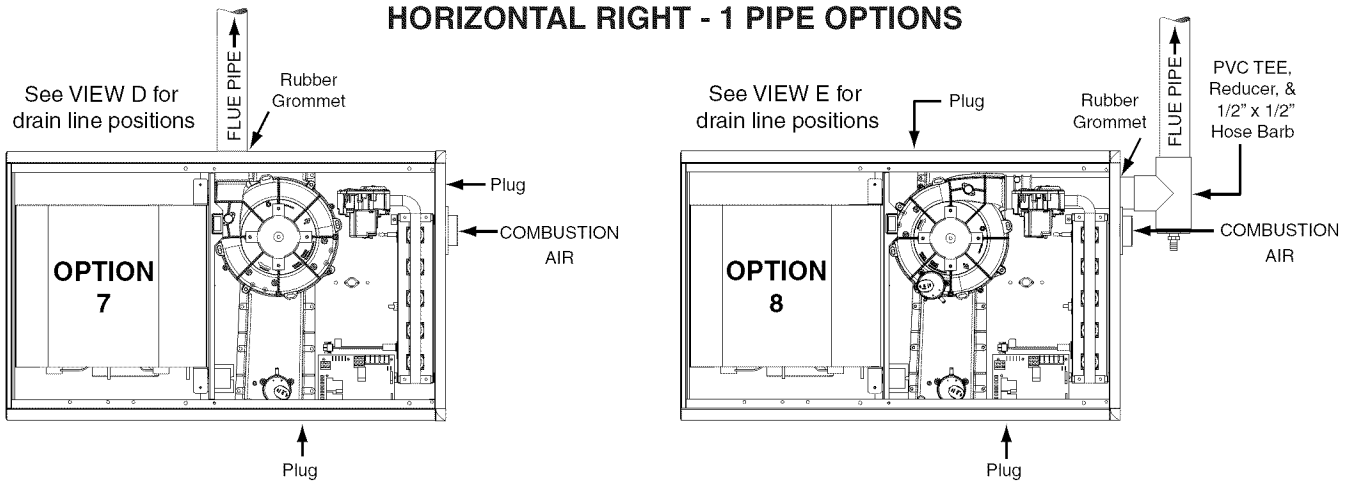
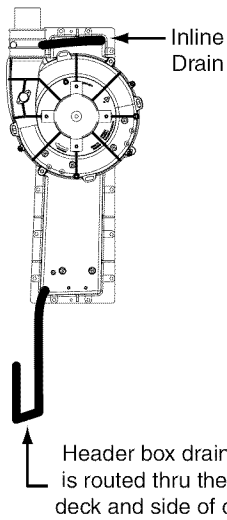

Figure 34. Upflow Options

HORIZONTAL RIGHT - 1 PIPE OPTIONS



VIEW -D-



VIEW -E-

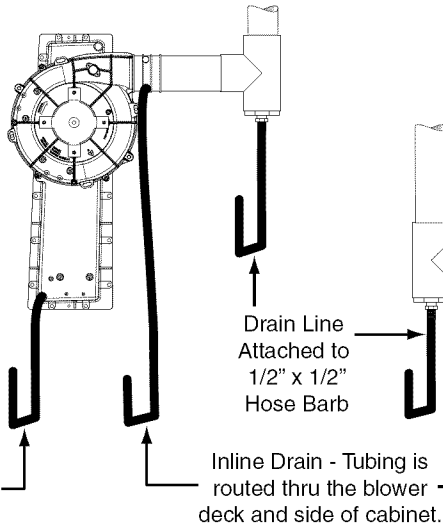

VIEW -F-

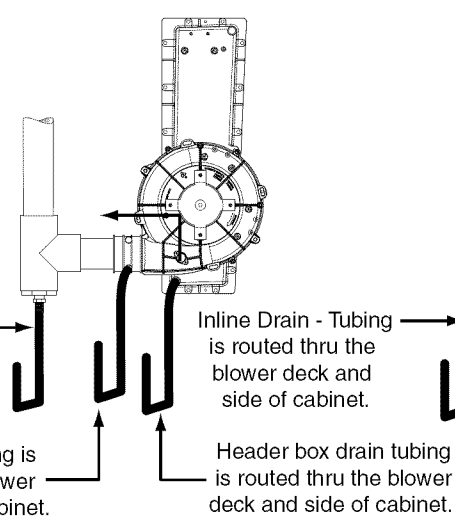

VIEW -G-

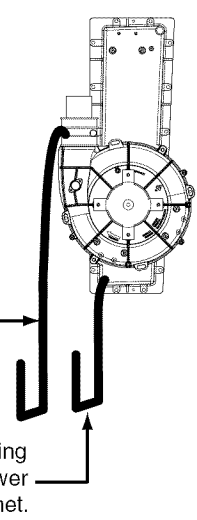

NOTES:

- 1.) All drain lines must be trapped with J-Trap or field supplied loop.
- 2.) Inline drain tubing may need to be cut to length to resemble illustration.

HORIZONTAL LEFT - 1 PIPE OPTIONS

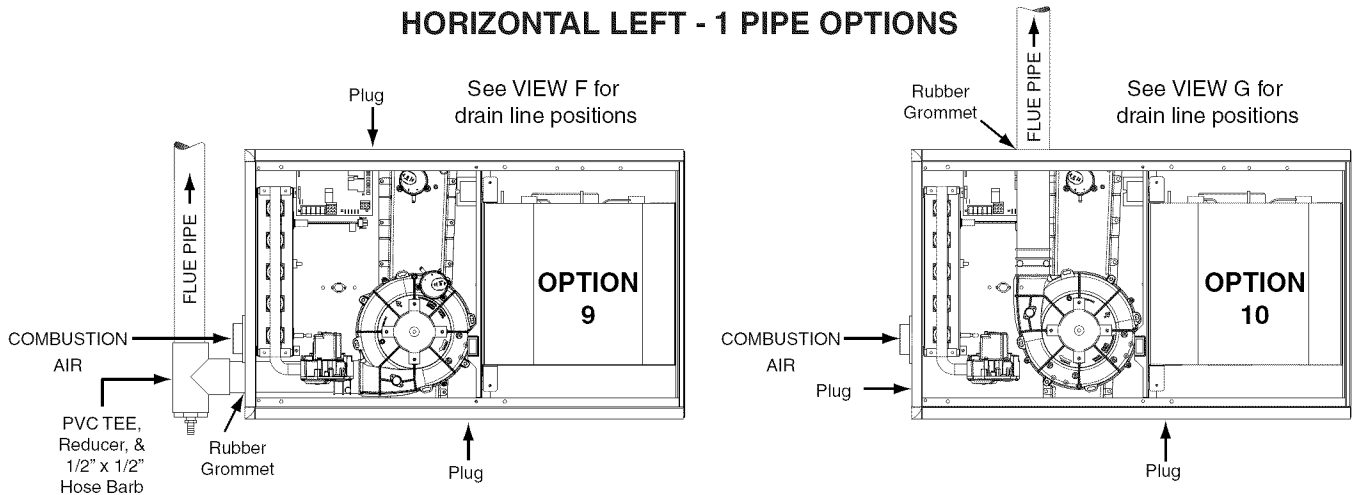
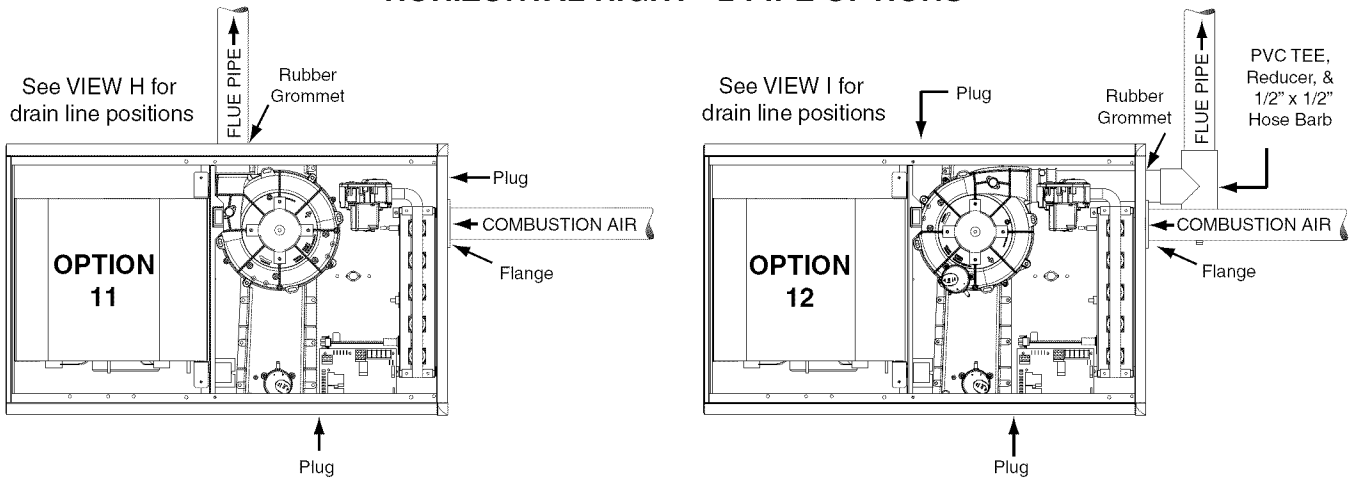
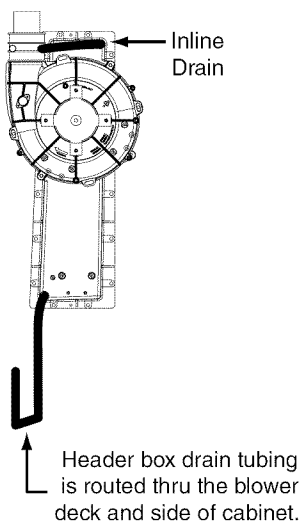

Figure 35. Horizontal Options - 1 Pipe Furnaces

HORIZONTAL RIGHT - 2 PIPE OPTIONS



VIEW -H-



VIEW -I-

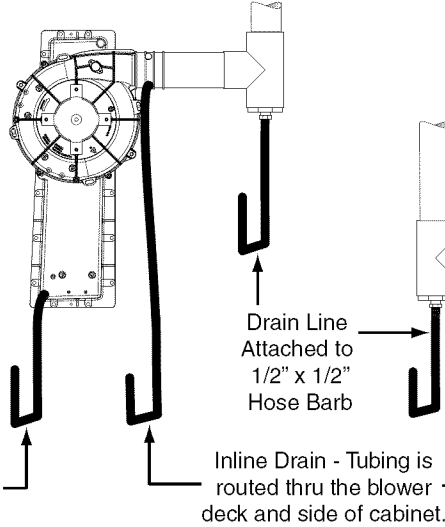

VIEW -J-

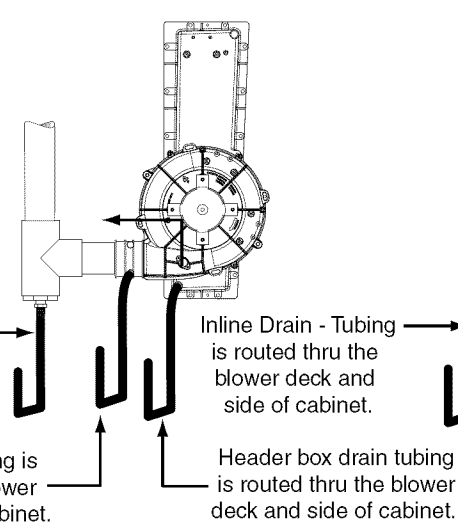

VIEW -K-

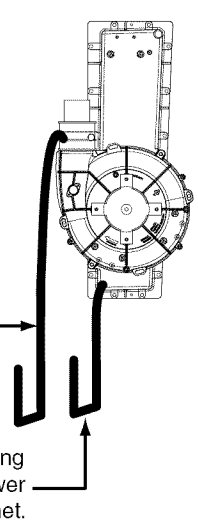

NOTES:

- 1.) All drain lines must be trapped with J-Trap or field supplied loop.
- 2.) Inline drain tubing may need to be cut to length to resemble illustration.

HORIZONTAL LEFT - 2 PIPE OPTIONS

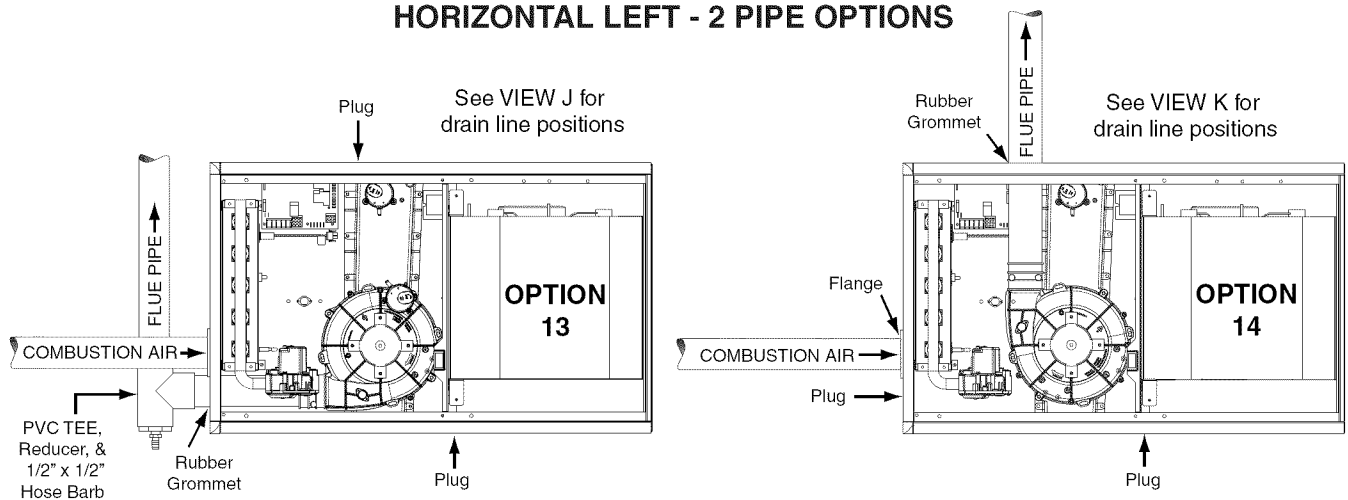
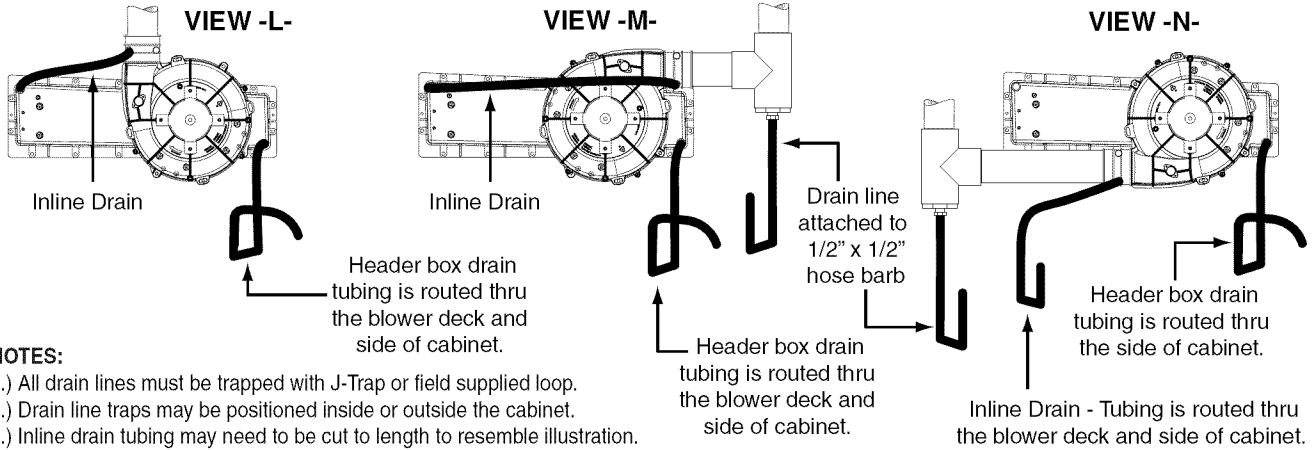
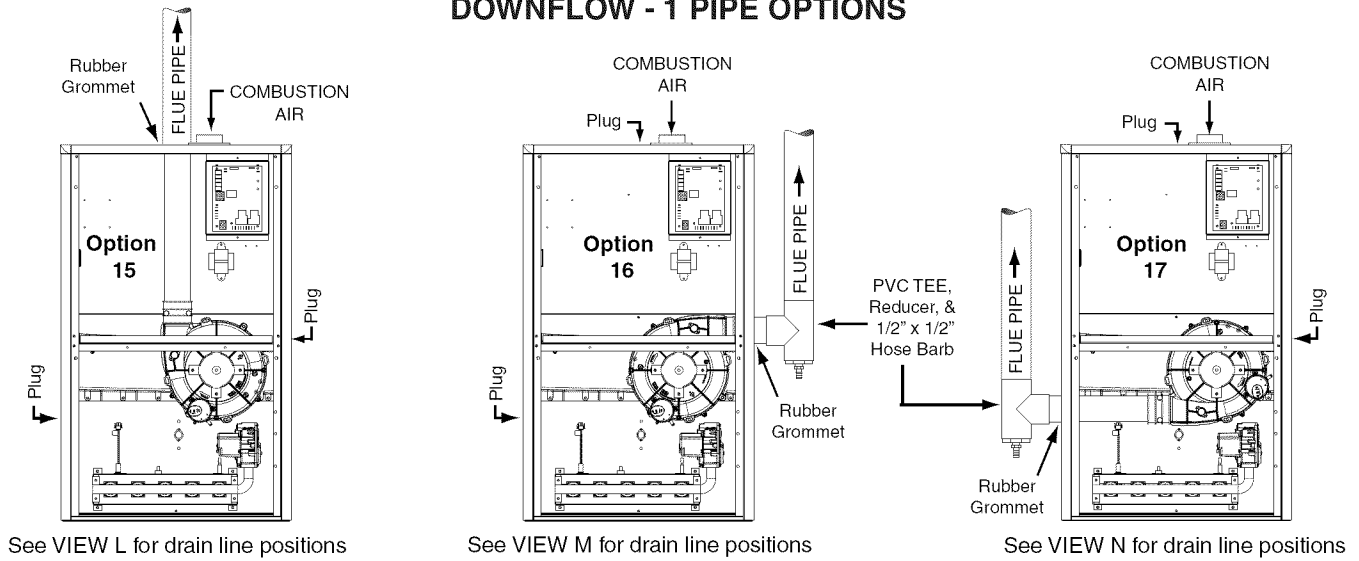

Figure 36. Horizontal Options - 2-pipe Furnaces

DOWNFLOW - 1 PIPE OPTIONS



DOWNFLOW - 2 PIPE OPTIONS

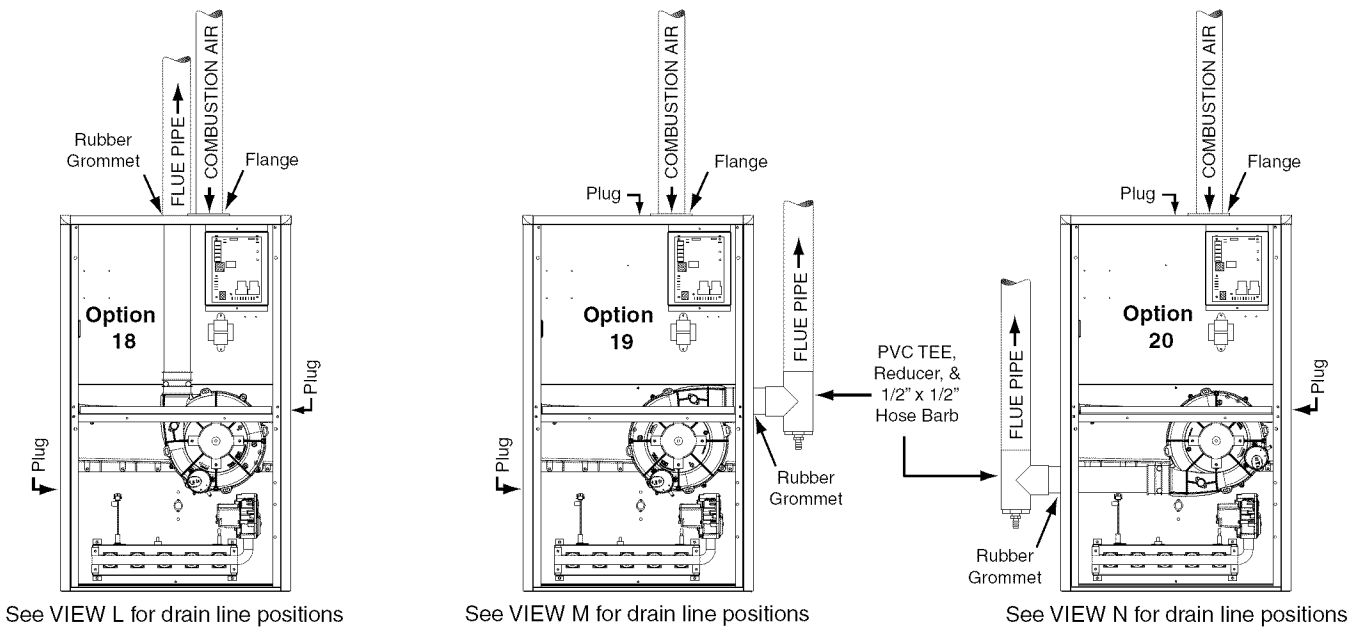
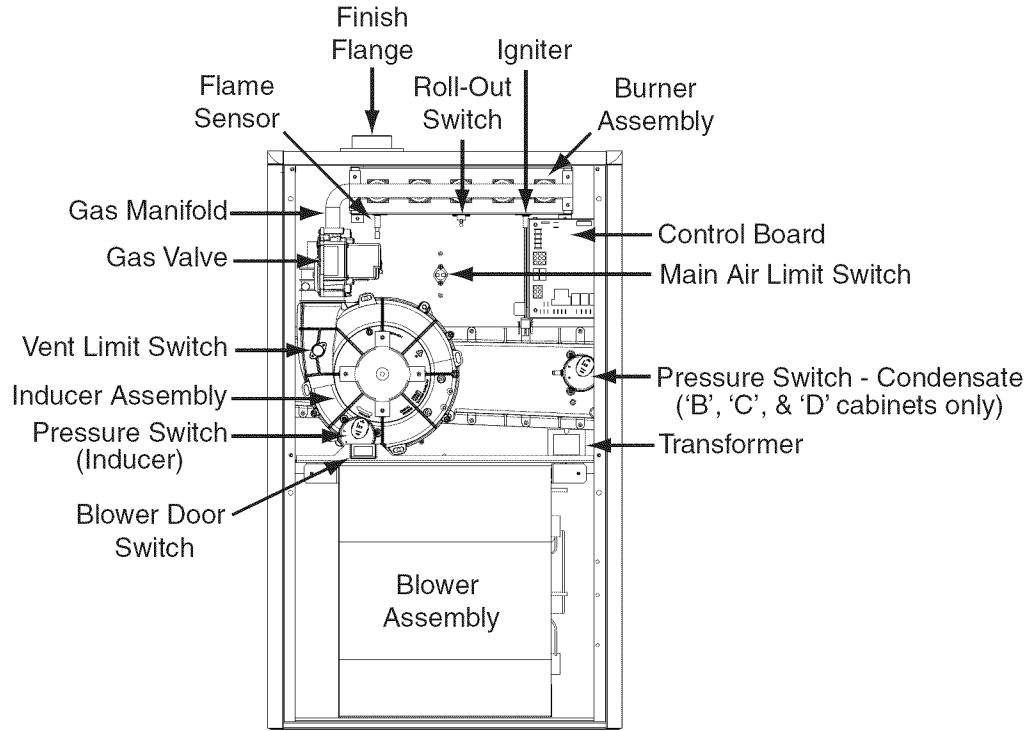
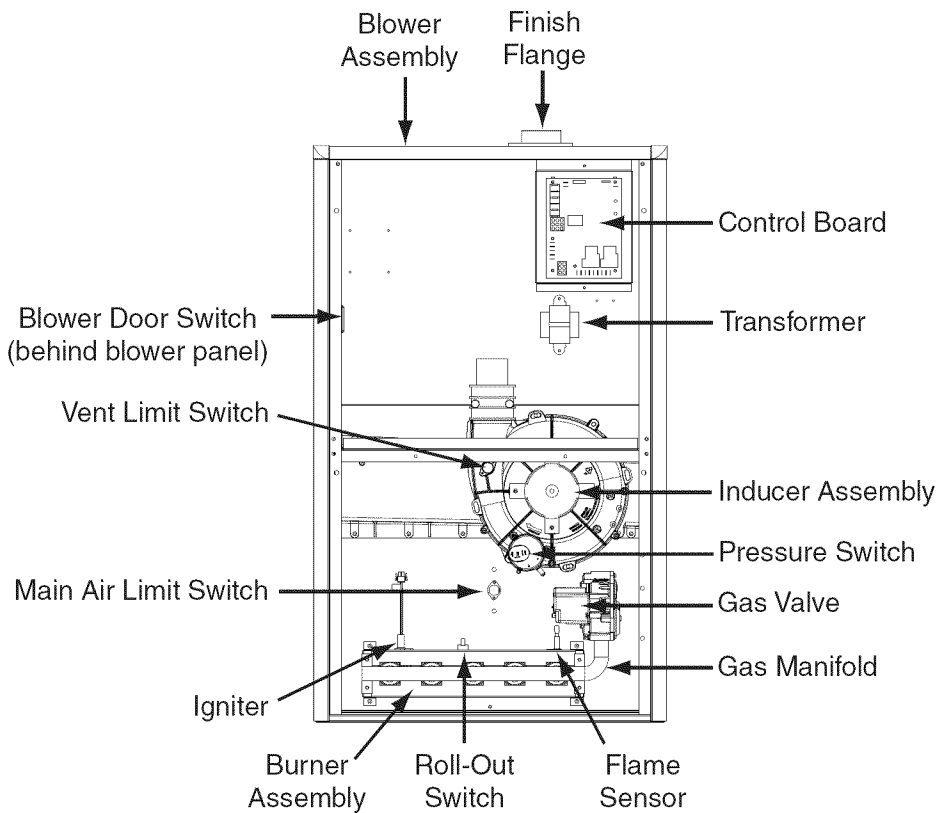

Figure 37. Downflow Options

LOCATION OF FURNACE COMPONENTS



***SC Upflow / Horizontal Furnace**



***SL Downflow Furnace**

Figure 38. Furnace Components

INSTALLATION / PERFORMANCE CHECK LIST

ATTENTION INSTALLERS:

It is your responsibility to know this product better than your customer. This includes being able to install the product according to strict safety guidelines and instructing the customer on how to operate and maintain the equipment for the life of the product. Safety should always be the deciding factor when installing this product and using common sense plays an important role as well. Pay attention to all safety warnings and any other special notes highlighted in the manual. Improper installation of the furnace or failure to follow safety warnings could result in serious injury, death, or property damage.

These instructions are primarily intended to assist qualified individuals experienced in the proper installation of this appliance. Some local codes require licensed installation/service personnel for this type of equipment. Please read all instructions carefully before starting the installation. Return these instructions to the customer's package for future reference.

INSTALLER NAME:

CITY:

STATE:

INSTALLATION ADDRESS:

CITY:

STATE:

UNIT MODEL #

UNIT SERIAL #

Minimum clearances per Table 1 (page 6)?

YES

NO

Has the owner's information been reviewed with the home-owner?

YES

NO

Has the literature package been left near the furnace?

YES

NO

⚠ WARNING:

PROPOSITION 65 WARNING: This product contains chemicals known to the state of California to cause cancer, birth defects or other reproductive harm.

ELECTRICAL SYSTEM:

Electrical connections tight?	YES	NO
Line voltage polarity correct?	YES	NO
Supply Voltage: _____ VOLTS		
Has the thermostat been calibrated?	YES	NO
Is the thermostat level?	YES	NO
Is the heat anticipator setting correct?	YES	NO

GAS SYSTEM:

Gas Type: (circle one)	Natural Gas	Propane
Gas pipe connections leak tested?	YES	NO
Gas Line Pressure: _____ (in - W.C.)		
Installation Altitude: _____ (FT.)		
Deration Percentage: _____ (%)		
Furnace Input: _____ (Btuh)		
Supply Air Temperature: _____ (° F)		
Return Air Temperature: _____ (° F)		
Temperature Rise: _____ (° F)		

COMBUSTION AIR & VENTING SYSTEM:

Is there adequate fresh air supply for combustion and ventilation?	YES	NO
Vent free from restrictions?	YES	NO
Filter(s) secured in place?	YES	NO
Filter(s) clean?	YES	NO
Flue connections tight?	YES	NO
Is there proper draft?	YES	NO



NORDYNE
COMPLETE COMFORT. GENUINE VALUE.

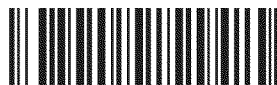

709046A

709046A (Replaces 7090460)

Specifications and illustrations subject to change without notice or incurring obligations.
Printed in U.S.A. (03/10)

O' Fallon, MO